

Musician's Manual

ESQ¹M
DIGITAL WAVE SYNTHESIZER MODULE



Musician's Manual
Version 1.0

ESQ-M Musician's Manual:

Written, Designed,
and Illustrated by:

Bill McCutcheon

Cover Design by:

Gilligan Designs, Inc.

Copyright © 1987
ENSONIQ® Corp
155 Great Valley Parkway
Malvern, PA 19355

All Rights Reserved

This Manual is copyrighted and all rights are reserved by **ENSONIQ Corp**. This document may not, in whole or in part, be copied, photocopied, reproduced, translated or reduced to any electronic medium or machine readable form without prior written consent from **ENSONIQ Corp**. The ESQ-M software/firmware is copyrighted and all rights are reserved by **ENSONIQ Corp**.

Although every effort has been made to ensure the accuracy of the text and illustrations in this Manual, no guarantee is made or implied in this regard. Software/firmware are sold as is and are not covered by warranty.

IMPORTANT:

"This equipment generates and uses radio frequency energy and if not installed and used properly, that is, in strict accordance with the manufacturer's instructions, may cause interference to radio and television reception. It has been tested and found to comply with the limits for a Class B computing device in accordance with the specifications in Subpart J of Part 15 of FCC rules, which are designed to provide reasonable protection against such interference in a residential installation. However, there is no guarantee that interference will not occur in a particular installation. If this equipment does cause interference to radio or television reception, which can be determined by turning the equipment off and on, the user is encouraged to try to correct the interference by one or more of the following measures."

- * reorient the receiving antenna
- * relocate the instrument with respect to the receiver
- * move the instrument away from the receiver
- * plug the instrument into a different outlet so that the instrument and receiver are on different branch circuits

"If necessary, the user should consult the dealer or an experienced radio/television technician for additional suggestions. The user may find the following booklet prepared by the Federal Communications Commission helpful: 'How to Identify and Resolve Radio-TV Interference Problems.' This booklet is available from the U.S. Government printing Office, Washington, D.C. 20402 Stock No. 004-000-00345-4."

In order to fulfill warranty requirements the ESQ-M should be serviced only by an authorized ENSONIQ Repair Station.

The ENSONIQ serial number label must appear on the outside of the Unit or the ENSONIQ warranty is void.

*ENSONIQ, ESQ-M, ESQ-1, and Mirage are trademarks of ENSONIQ Corp.

ESQ-M Musician's Manual — Table of Contents 7
Introduction**9 Section 1– Getting Started****10 Basic Connections**

- 10 Power
- 10 MIDI
- 10 Amplification
- 11 Rear Panel Connections
- 12 Front Panel Controls

15 Making Noise

- 15 Turn it on
- 15 The Sounds
- 16 Internal Memory
- 16 Cartridge Memory
- 17 Selecting a Program
- 17 Changing Programs Remotely
- 17 A Note About Program Numbers
- 18 When You Remove the Cartridge

18 Battery Maintenance**18 Rack-mounting the ESQ-M****19 Section 2 - Getting in Deeper****20 PROGRAM Mode - Changing Programs & Tracks**

- 20 Changing Programs
- 20 Track 0
- 21 Changing Tracks
- 21 More About Tracks
- 22 Diagram — The ESQ-M as Nine "Virtual" Synthesizers

23 PARAMETER Mode

- 23 About Parametric Programming
- 23 Pages
- 23 The Param button
- 24 The Control Keypad
- 24 Selecting a Page
- 24 Selecting a Parameter
- 25 Parameter Chart
- 26 Changing a Parameter
- 26 The Compare light/*C* Prompt
- 27 The Edit Buffer & the Edit Program

29 Section 3 - "Global" Functions

- 30 **MASTER Page**
 Controls Master Tuning, Velocity Sensitivity, Pedal Function & Pitch Bend 32
- MIDI Page**
 Controls The ESQ-M's MIDI Configuration

39 Section 4 - Programming the ESQ-M

- 40 **Waveforms**
 - 40 Digital Waveform Memory
 - 40 What's a Waveform?
 - 40 Synthetic Waveforms
 - 40 Sampled & Multi-sampled Waveforms
 - 41 Names
 - 41 Selecting a Waveform
 - 41 Check Them Out
 - 42 The Waveforms
 - 45 **Modulators**
 - 45 About Modulation
 - 45 Selecting a Modulator
 - 46 Modulation Depth
 - 46 Modulation Sources
 - 46 LFO's (1-3)
 - 47 Envelopes (1-4)
 - 47 Velocity (VEL & VEL 2)
 - 48 Keyboard Tracking (KYBD & KYBD 2)
 - 48 Mod Wheel (WHEEL)
 - 49 Foot Pedal (PEDAL)
 - 49 External Controller (XCTRL)
 - 49 After-touch (PRESSR)
 - 50 Using Modulators
 - 50 Modulating Oscillator Volume
 - 51 Negative Modulation
 - 51 Modulating Filter Cutoff Frequency
 - 52 Limits of Modulation

 - 53 **Voice Diagram - ESQ-M Voice Architecture**

 - 55 **Programming Pages**
 - 56 OSC (1 - 3) Pages
 - 58 DCA (1-3) Pages
 - 60 DCA 4 Page
 - 62 FILTER Page
 - 64 LFO (1-3) Pages
 - 66 Understanding the Envelopes
 - 72 ENV (1-4) Pages
 - 74 MODES Page
 - 77 Split/Layer Page
-

81 Programming Conventions**83 Section 5 - Saving and Storing Programs (& "Hidden" Functions)****84 Write Page**

- 84 Saving a New or Edited Program
- 85 Bailing Out
- 85 Copying an Existing Program to Another Location

86 Storage Page — Data Transfer

- 86 MIDI Transfer of Programs
- 86 MIDI Connections
- 86 PROG TO MIDI - Sending One Program via MIDI to another ESQ
- 87 BANK TO MIDI - Sending All Internal Programs to another ESQ
- 87 Cartridge - Bank Copy
- 87 Transferring Cartridge Programs to the Internal Memory
- 87 CART A TO INT
- 88 CART B TO INT
- 88 Transferring Internal Programs to a Cartridge
- 88 INT TO CART A
- 90 INT TO CART B

89 Hidden Functions

- 89 How to Find them
- 89 Functions:
- 89 Soft Reset
- 89 Software Version
- 90 Memory Reset
- 90 Filter Tune
- 90 Analog Tests

91 Section 6 - Applications**93 Using the ESQ-M with a sequencer**

- 93 Connections
- 93 The ESQ-M as one synthesizer
- 94 The ESQ-M as nine synthesizers
- 94 Some important points about MULTI Mode

95 Using the ESQ-M with a MIDI Guitar Controller**97 The ESQ-M in conjunction with an ESQ-1**

- 97 Programming the ESQ-M from an ESQ-1: System Exclusive Messages
- 97 Sequencing the ESQ-M from an ESQ-1
- 98 MIDI Overflow Mode - the ESQ-M as a voice expander for an ESQ-1

101 Section 7 - Appendices

102	About the Program Sheet
102	ESQ-1 to ESQ-M Parameter Reference
103	Blank Program Sheet
104	Program Control Block Structure
107	ESQ-M MIDI Implementation Chart
108	ESQ-M MIDI Implementation Specifications
111	ESQ-M MIDI Parameter List
116	ESQ-M Specifications

CONGRATULATIONS

Your new ESQ-M Digital Wave Synthesizer Module gives you all the great sounds and true multi-timbral capabilities of ENSONIQ'S ESQ-1 Digital Wave Synthesizer in a compact, rack-mountable package.

If all you want to do is play one sound at a time from a remote keyboard (as you would with most MIDI voice modules), you'll find the ESQ-M to be a versatile synth with a wide variety of sounds to choose from. If, however, you are one of those who likes to explore every capability of an instrument, and tends to push things to the limit, you are in for a treat. The ESQ-M is just the kind of machine you've been waiting for.

The voice architecture of the ESQ-M is exactly the same as that of the ESQ-1 – all ESQ-1 sounds play just fine on the ESQ-M, and vice versa. The ESQ-M gives you full access to all the same programming pages and parameters that have made the ESQ-1 a favorite among programmers and players alike.

Like the ESQ-1, it has:

- forty Internal Programs
- a cartridge slot for an STC-8 Program cartridge for 80 more programs
- true stereo output (Left/Mono and Right audio outs)
- a CV/Pedal input
- eight dynamically assigned voices
- true poly-timbral operation, able to receive polyphonically on nine MIDI Channels at once

Unlike the ESQ-1, the **ESQ-M** *does not* have the built-in sequencer.

TRACKS?

The ESQ-M does, however, have Tracks. Since there is no sequencer, you may ask, what do Tracks have to do with anything? Well, a Track on the ESQ-M functions the way a Track of an ESQ-1 sequence does when you send it MIDI information from a remote instrument. The Tracks are the mechanism by which we are able to play multi-timbrally (using different sounds simultaneously) into the ESQ-M. Each Track can "listen to" a different MIDI Channel, and respond polyphonically to information coming in on that Channel.

Each Track is a separate *MIDI target* with its own:

- Program (patch)
- Program number
- MIDI Channel
- Volume (mix) level

There are *nine* Tracks, numbered 0-8. Conceptually, Tracks 1 through 8 correspond to the Tracks of the ESQ-1 sequencer, and Track 0 corresponds to the "straight synth" section of the ESQ-1. In most ways Track 0 is identical to the other eight Tracks.

When the ESQ-M is in MULTI Mode, each track will receive independently on its own MIDI Channel, each with its own Program and mix level. This makes the ESQ-M ideal for use with a sequencer, or with a controller keyboard capable of sending different "zones" of the keyboard on different MIDI Channels. You can address up to nine different sounds on the ESQ-M without ever sending it a Program Change, just by playing into the unit on different MIDI Channels.

The ESQ-M, in effect, can act like nine separate synths set to receive on nine different MIDI Channels. The only catch is that those nine synths share the same eight voices, so no more than eight voices can be playing at any one instant. You'll find that this usually isn't much of a limitation. Most of the time you won't be using all eight voices, and the ESQ-M's ability to play lots of different sounds at once can make eight voices sound like a whole band.

Also, the **ESQ-M's** MONO Mode implementation makes it excellent for use with the new generation of MIDI guitar controllers, allowing one, for example, to play a different sound on each string.

FEATURES

With three Digital Wave Oscillators per voice, thirty-two sampled and synthetic Waveforms to choose from, and 15 routable Modulation sources, the ESQ-M is capable of producing a wide variety of rich, complex sounds. You can program *Splits* (for different sounds on each half of the keyboard), *Layers* (for two sounds playing together), or even a *Split/Layer* mode, in which two totally different pairs of sounds play on each keyboard half.

Forty Programs, or 'patches', are stored in the Internal Memory, with another eighty available on an external, plug-in Cartridge, giving you 120 sounds to select from instantly. These Programs can be played as is, or they can be modified to suit your taste and then renamed and stored, either in the Internal or the Cartridge Memory.

Editing of all programs, and 'global' functions (such as Master Tuning, Bend Range, MIDI Channels, etc.) can be done easily from the front panel, using the 16 character fluorescent display. Or, you can program the ESQ-M remotely from an ESQ-1 or a computer (with the right software), by enabling the ESQ-M to receive System Exclusive messages.

Audio outputs are provided for true stereo as well as a mono output. Programs can be panned continuously between the left and right channels. The ESQ-M also has an Amplitude Modulation (AM) mode which can produce bell and ring-modulator type effects, and a Sync mode for hard sync effects.

ENJOY

Getting great sounds out of the ESQ-M is simple – just read the section entitled **Getting Started**, then plug it in and play. Learning to take full advantage of its enormous flexibility will take a bit longer—it will do a lot. However, if you can open your mind to a few new concepts (like Track 0), allow yourself to experiment a little, and when all else fails read the Manual, you'll find the ESQ-M becoming one of the most-used, and most useful, instruments in your entire rig.



Section 1 — Getting Started

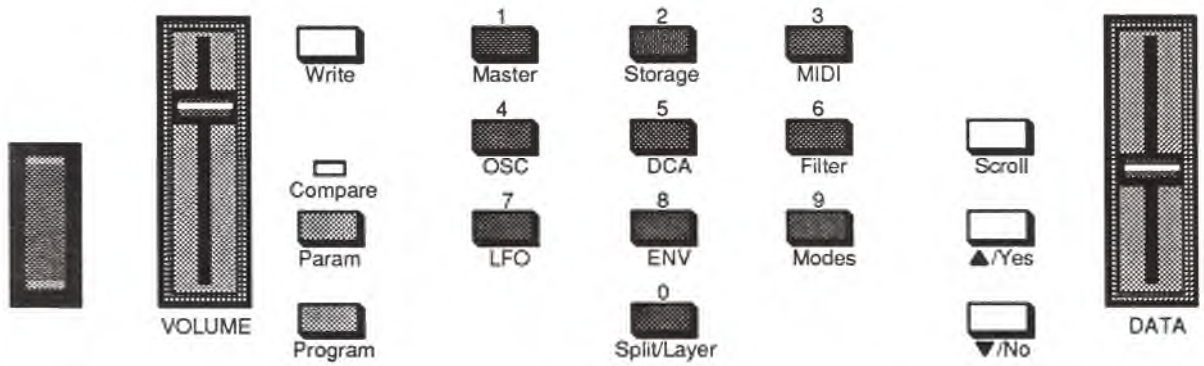

BASIC CONNECTIONS

POWER

Insert the Power Cable into the receptacle on the back of the ESQ-M. Plug the other end of the cable into a grounded AC outlet. (The proper voltage for your ESQ-M is listed on the Serial Number Label on the Rear Panel.) Turn on the ESQ-M and make sure the Display lights up. If not, check your connections and power source.

MIDI

Of course, you'll need to connect the ESQ-M to a MIDI keyboard or other controller before it will make any noise at all. Any instrument which has a MIDI OUT jack can be used to drive the **ESQ-M**.

Connect the MIDI OUT jack of the master instrument to the MIDI IN jack of the ESQ-M as shown below, using a standard 5-pin MIDI cable.

If you want to drive additional instruments from the same master keyboard, connect the MIDI THRU jack of the ESQ-M to the MIDI IN jack of the next instrument in line. This jack simply "passes along" the signal received at the MIDI IN jack, without transmitting any data generated by the ESQ-M itself.

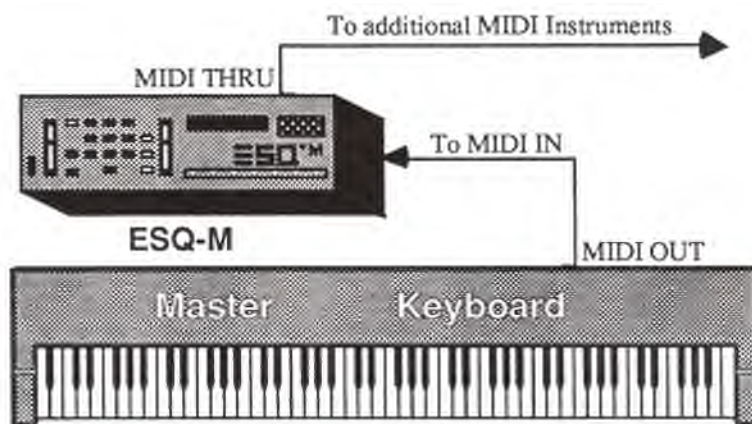

AMPLIFICATION

Make sure your Audio system is turned off (or down) when making connections, to avoid damaging speakers or other components.

Connect the Audio Outputs of the ESQ-M to a mixer, instrument amplifier, stereo, or any other sound system, using 1/4 inch audio cables. If your system is stereo, connect the Left/Mono and Right Outputs to two channels of your mixer, stereo, etc. If not, use the ESQ-M's Left/Mono Output only.

If you're running the ESQ-M through a mixer, in stereo, be sure to pan the Left input fully left, and the Right input fully right.

Move the Volume Slider of the ESQ-M up about half way. Switch the audio system On. While playing the master keyboard, adjust the amplifier volume for normal listening levels. If you hear no sound from the ESQ-M while playing the master keyboard, switch the audio system Off and check your audio and MIDI connections.

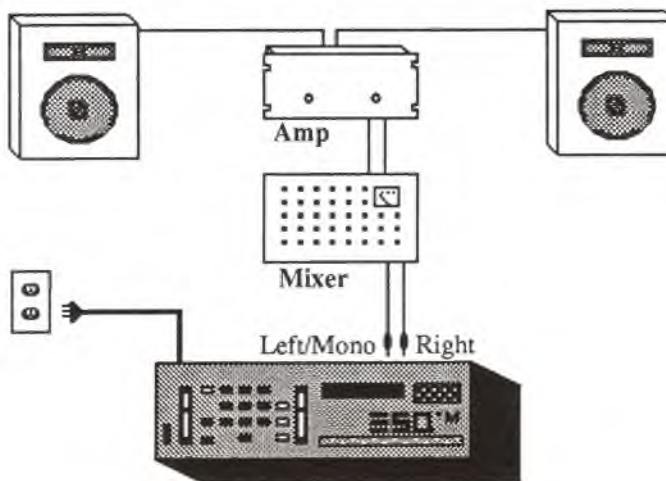

REAR PANEL CONNECTIONS

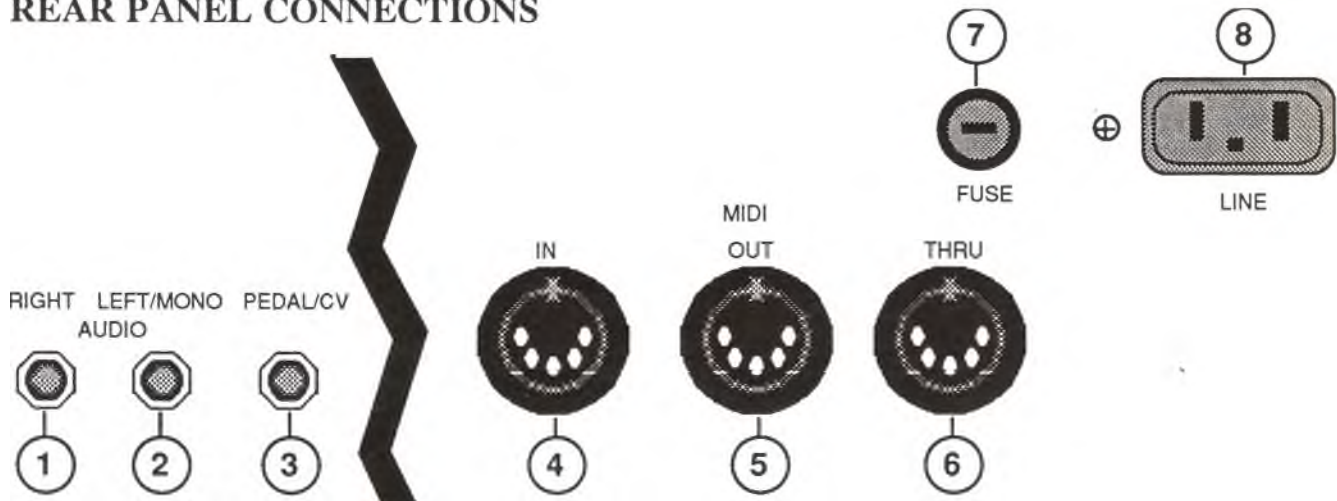

AUDIO OUTPUTS:

1. RIGHT -- To operate the ESQ-M in Stereo, connect this Output to a channel of your Mixer and pan that channel Right. If nothing is connected to this jack, both channels of the ESQ-M's Output will be combined and sent out the **Left/Mono** Output.

2. LEFT/MONO -- When operating the ESQ-M in Stereo, connect this Output to a channel of your Mixer and pan that channel Left. To operate the ESQ-M in Mono, use this jack only. Again, if nothing has been connected to the **Right** Output jack, the **Left/Mono** jack will produce a Mono signal that is the sum of the two channels of the ESQ-M's Output. **Specs:** (Both Audio Outputs): 1 KOhm output impedance, DC coupled. Line level output into 10 KOhms or higher (one voice=1 Vp-p typical; all voices= 15 Vp-p)

3. CV/PEDAL

This jack is for connecting an optional ENSONIQ Model SW-10 Control Voltage Foot Pedal, which is assignable as a Modulator in the Program Section of the ESQ-M. (Note that incoming MIDI Foot Pedal information (MIDI Controller #4) will have the same effect.) Or, the CV Pedal can serve as a Volume Pedal when PEDAL=VOL is selected on the MASTER Page.

Specs: [Pedal Input]: 3-conductor (Tip=control voltage input, Ring=2KOhm resistor to +12 Volts, Sleeve= ground). 500 KOhm input impedance, DC coupled. Input voltage range=0 to 10 volts DC. Scan rate=5mS (maximum recommended modulation input= 25 Hz). For use with an

external control

voltage, use a 2-conductor cable with the voltage on the tip and the sleeve grounded.

4. MIDI IN

Receives MIDI information from other instruments or computers. The MIDI Output of a MIDI keyboard or other controller must be connected to this input with a standard Spin MIDI cable in order for the ESQ-M to make any sound.

5. MIDI OUT

This jack sends out MIDI (Musical Instrument Digital Interface) information to other instruments and computers. Since the ESQ-M is primarily a receiving unit, much of the time there won't be a reason to plug anything into this jack. It is important mainly for sending data, such as Program Banks, to other ESQ products and computers.

6. MIDI THRU

This jack "passes along" all information received at the ESQ-M's MIDI In jack. It is used for chaining MIDI devices together when driving multiple instruments from a master keyboard or sequencer.

7. FUSE 1 amp fast-blow fuse socket.

8. AC LINE IN

The supplied line cord should be connected here. The correct voltage for the ESQ-M is listed on the Serial Number label on the rear panel. If you travel, remember that the ESQ-M will only operate on this voltage.

FRONT PANEL CONTROLS

All the programming, performance and data transfer functions of the ESQ-M are handled from the sixteen Front Panel buttons, the Volume and Data Entry Sliders, and the 16-character fluorescent Display. Many of the controls perform multiple functions depending on what mode the ESQ-M is in. You should read the following descriptions carefully in order to get the most out of your ESQ-M.

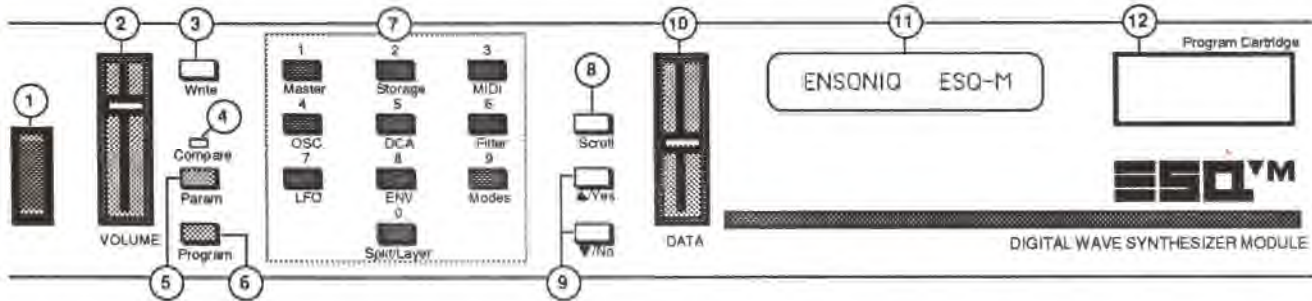

1. POWER

Rocker switch to turn the unit's power on and off. Press the switch at the top to turn the ESQ-M on; at the bottom to turn it off. You should always make sure the volume is turned down on your mixer or amplifier before turning the ESQ-M's power on or off.

2. VOLUME

Slider control to adjust the output volume of the ESQ-M.

3. Write button

This button is used to put the ESQ-M onto the **WRITE** Page, where new or edited Programs can be saved to Internal or Cartridge memory locations. The button is also used to initiate the actual Write (or save) procedure once you have decided on a new name and memory location for the new Program. See Section 5 for complete details.

4. Compare light

This LED lights when you change any of the parameters of the current Program. What the Compare light is actually telling you when it's lit is that the Program you are listening to is the Edit Program — the contents of the Edit buffer. Pressing the **Param** button again will cause the ESQ-M to switch back to the current Program, causing the Compare light to go out. For more information about the Edit buffer and using the Compare function, see pp. 26-27.

5. Param button

Pressing this button puts the ESQ-M into

Parameter mode. In Parameter mode the various parameters (or variables) that make up the ESQ-M's Programs and its "Global" settings can be selected and modified.

In Parameter mode the display shows:

- 1) the name of the current Page
- 2) the currently selected parameter on that Page, and
- 3) the current value of that parameter.

Once the ESQ-M is in Parameter mode, pressing the **Param** button toggles back and forth between the Edit Program and the currently selected Program in the ESQ-M's memory, causing the Compare light to go on or off (see above). See pp. 23-27 for more on Parameter mode.

Pressing the **Param** button also allows access to the **Storage** Page, which is not technically a parameter page, but which has a format similar to the parameter pages. The **Storage** Page handles all the data transfer functions of the ESQ-M (sending Programs over MIDI, transferring Program banks between the Cartridge and the Internal Memory, etc.) From the **Storage** Page you can also execute a number of "hidden" functions, such as tuning the filters, re-initializing the memory, checking the software version number, etc. These "hidden" functions are covered in Section 5.

6. Program button

Pressing this button puts the ESQ-M into **Program mode**. This is the normal performance mode, the one your ESQ-M will probably be in most of the time.

In Program mode the display shows:

- 1) the number of the current Track
(ex.— TRK 0),
- 2) the name of the Program (or "patch") currently selected on that Track
(ex.— PIANO1), and
- 3) the Program number of that Program in the Internal or Cartridge memory
(ex.— 001).

You can always press the **Program** button to quickly find out what Program is selected on the current Track. See Section 2 for an explanation of Program mode.

7. CONTROL KEYPAD

The ten buttons of the **Control Keypad** are each labeled with a number (as on a standard numeric keypad) and a Page Name. These buttons perform a number of different functions, depending on what mode the ESQ-M is in, and what you did immediately before pressing the button. Each of these functions is described in more detail in the relevant section of this manual.

In Program mode, the buttons of the **Control Keypad** can be used to directly key in the number of the Program you want to select. The full 3 digit number, including zeroes, must be entered. (For example, enter 0-0-2 to select Program # 2; enter 0-3-5 to select Program # 35.)

In Parameter mode, these ten buttons select the **Pages** which contain the various parameters available on the ESQ-M. Where there are more than one of a certain kind of Page, (such as OSC 1, OSC 2, and OSC 3) you are asked, after pressing OSC, to enter the number of the Oscillator you want. You have approx. 2 seconds to enter a valid number.

The buttons of the **Control Keypad** also allow you to take a short cut to any particular parameter (bypassing the Scroll button), by entering the parameter number immediately after you select the Page. Again, you have approx. 2 seconds to enter a valid number

after selecting a Page.

On the Write Page, you can use these buttons to directly enter the Program number of the memory location to which you want to save a new or edited Program.

IMPORTANT: In all the above functions the buttons of the **Control Keypad** are subject to a *timing cycle*. That is, when you select OSC, the ESQ-M waits about 2 seconds for you to tell it *which* OSC you mean (1, 2 or 3). If you don't respond in that time, the Display goes back to wherever it was previously. Once you select a Page, the ESQ-M again waits about 2 seconds for you to directly enter a parameter number, after which it assumes that a new button-press is meant to select a different Page. If you find yourself furiously pressing lots of buttons and not getting the results you expect, slow down, let a few seconds pass so that all timing cycles are out of the way and then select your page, parameter, etc.

8. Scroll button

The Scroll button has various functions depending on what mode the ESQ-M is in:

In Program mode, pressing the Scroll button will advance to the next higher Track. At Track 8 the ESQ-M will "wrap" around to Track 0 when Scroll is pressed.

In Parameter mode, pressing Scroll advances to the next Parameter on the current Page. Again, the Display will "wrap" after the last parameter on a Page, cycling endlessly through the available parameters as the Scroll button is repeatedly pressed.

On the Write Page, pressing Scroll advances the cursor to the next character, or to the destination Program number, as you select a name and a new location for an edited sound.

On the Storage Page, once you have selected the Storage (or data transfer) function you want, you press the **Storage** button *while holding down the Scroll button* to initiate the transfer.

NOTE that pressing the Scroll button only scrolls the Display forward, to the next higher Track, parameter, character, etc. You

can, however, scroll backwards, to the previous Track or parameter by holding down the Scroll button and pressing the **Down Arrow/No** button. In fact, whenever you are holding down the Scroll button, the Data Entry Slider and the Up and Down Arrow buttons will perform the Scroll function instead of their usual functions.

As for the Scroll button itself, you will notice that any actions performed by this button actually occur when you release the button, not when you first press it. So when we say "press the Scroll button" in this manual, what we *really* mean is "press and release the Scroll button."

9. Up Arrow/Yes and Down Arrow/No buttons

Also called INC and DEC (for increment and decrement) buttons, these two buttons perform various functions depending on what mode the ESQ-M is in. In almost every case, these buttons perform the same function as the Data Entry Slider. The difference is that pressing the Up and Down Arrow buttons changes things one value at a time, while moving the Data Entry Slider sweeps quickly through all the available values.

In Program mode, pressing the Up or Down Arrow button will select the next higher (or lower) Program to be the current Program on the Track. So, where pressing Scroll selects a new Track, pressing the Up or Down Arrow buttons changes the Program that will play on that Track.

In Parameter mode, pressing the Up or Down Arrow button will change the value of the current Parameter (the one showing on the Display). So, where pressing Scroll selects a different parameter, pressing the Up or Down Arrow buttons changes the value of that parameter.

On the Write Page, pressing the Up or Down Arrow button will change the flashing character one character, or one digit, at a time, as you edit the name and select a new location for an edited sound.

Yes/No Functions: Occasionally, when performing a function which will alter the contents of the ESQ-M's memory, you will be asked a question before proceeding, such as "RESET ALL MEMORY?" In such cases you will use these buttons to either

answer "YES" and proceed, or answer "NO" and cancel the procedure.

Scroll Functions: As mentioned above, when the Scroll button is being held down, the Up and Down Arrow buttons (and the Data Entry Slider) perform the Scroll functions instead of their normal ones. The most common application of this is to press the Down Arrow/No button while holding down the Scroll button, in order to scroll back to the previous parameter.

10. Data Entry Slider

The Data Entry Slider generally performs the same function as the Up and Down Arrow buttons. However, it sweeps through the entire range of available values, whereas the buttons adjust values one step at a time. It is often most effective to use the Data Entry Slider to "get in the neighborhood" of the Program or value you want, and then use the Up and Down Arrow buttons to zero in on the exact value.

The same descriptions given above for the Up and Down Arrow buttons apply for the functioning of the Data Entry Slider, with a few exceptions:

Yes/No Functions: When the ESQ-M expects a YES or NO answer to a question, the Data Entry Slider will be ignored, and only the Up Arrow/Yes or Down Arrow/No button may be used to respond.

Write Page: On the Write Page you can press the Down Arrow/No button while holding down the Scroll button to scroll backwards, but moving the Data Entry Slider with the Scroll button held down will have no effect.

11. Display

The 16-character vacuum fluorescent display provides all the necessary info about Track, Program and Global settings, as well as data transfer and other procedures.

12. Program Cartridge Slot

Insert an ENSONIQ STC-8 or other Program cartridge into this slot to expand the number of available Programs to 120.

Programs 041 through 120 are the Cartridge Programs. When no cartridge is inserted here, only Programs 001 through 040 (the forty internal Programs) can be selected. The contents

of an ENSONIQ Program cartridge are divided into **Banks** of forty Programs each:

Bank A contains Programs 041 through 080;
Bank B contains Programs 081 through 120.

MAKING NOISE

TURN IT ON

When you turn the **ESQ-M** on, the Display will show a wake-up message

ENSON IQ ESQ-M

TRK 0 PIANO 1 001

After about three seconds the **ESQ-M** will put itself into Program mode, and should default to "TRACK 0, Program #1. The Display should now show

If you've been playing with the controls, and the Display doesn't appear as shown above, do this:

1. Press the **Program** button
2. Move the Data Entry Slider up and then all the way down

What you have just done is to 1) put the ESQ-M into Program mode, and then 2) select Program #1 (by moving the Data Entry Slider all the way down). The ESQ-M is now on Track 0 with Program #1 selected. This is a good starting point for exploring the sounds.

THE SOUNDS

Each of the three Program Banks, (**Internal, Cart A** and **Cart B**) designates a large area of memory which contains forty Programs. If no cartridge is inserted in the Cartridge port, only the forty Internal Programs are available. Once a Cartridge is inserted, all 120 Programs are instantly available.

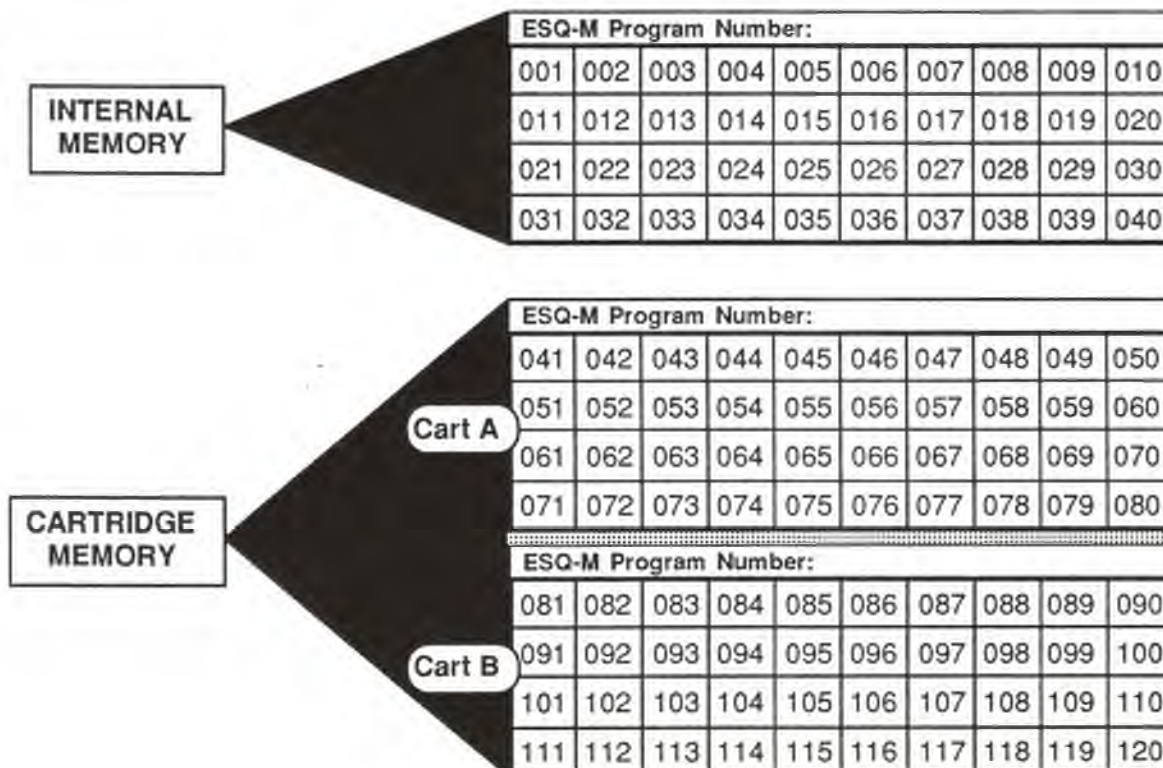

INTERNAL MEMORY (001-040)

The ESQ-M holds 40 different Sounds, or "patches" in its **Internal Memory**. We refer to these Sounds as **Programs**. You can change Programs simply by moving the Data Entry Slider or by pressing the Up and Down Arrow buttons. You can also change Programs on the **ESQ-M** by sending it a Program Change from your Master keyboard. For most MIDI keyboards, this is simply a matter of selecting a new Program from the front panel of the master keyboard.

The Internal Memory consists of Programs 001 through 040. (Note that the Program Number of the current Program on a given Track is always shown on the right side of the Display.) The Internal Memory retains its data even when the power is Off.

CARTRIDGE MEMORY (041-120)

Before you can select Programs 041 through 120, an ENSONIQ **E² PROM** or Voice-80 Storage Cartridge must be inserted in the Cartridge slot on the right side of the front panel.

Be sure to insert the Cartridge as shown below, with the label side facing down and the writing on the end of the Cartridge facing right-side-up.

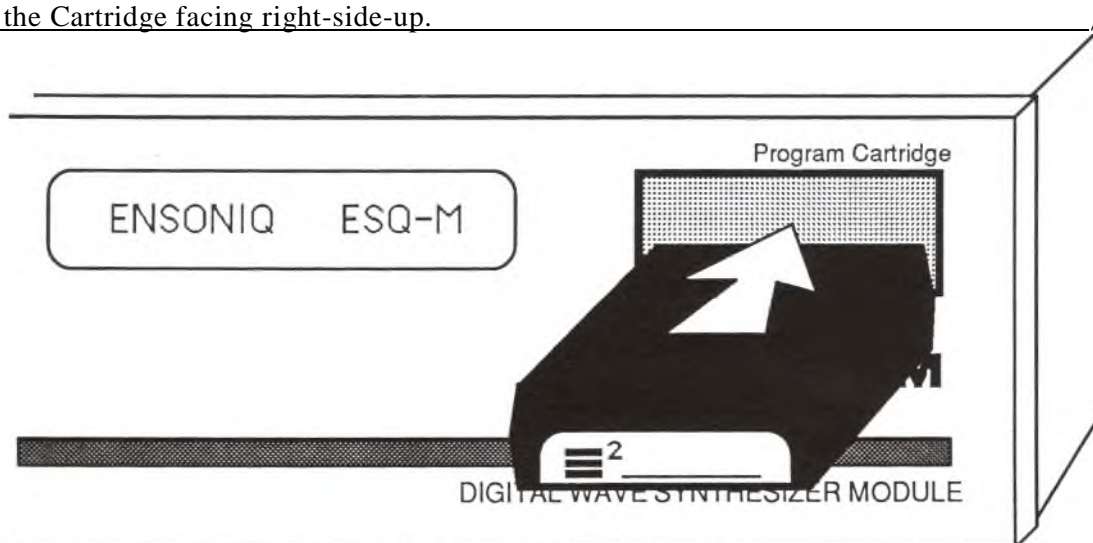

The Cartridge Memory consists of Programs 041 through 120.

The contents of an ENSONIQ Program cartridge are divided into two **Banks** of forty Programs each. **Bank A** contains Programs 041 through 080. **Bank B** contains Programs 081 through 120.

The procedures for selecting, editing and saving sounds are identical to those for Internal sounds. When a Cartridge has been inserted, all three Master Banks (that is, Programs 001 through 120) are instantly available.

There is one important difference between the **STC-8 E² PROM** Storage Cartridge and the Voice-80 Program Cartridges — you cannot "write to" or alter the contents of the Voice-80 Cartridges. They are read-only devices and the sounds on them cannot be changed (though you can edit a sound from the Voice-80 Cartridge and then save it somewhere else). The **E² PROM** Cartridge, on the other hand, is for storing the Programs that you create or get from your friends. You can write to it just like the Internal memory.

The **E² PROM** Cartridge also retains its data when the power is Off, whether or not it is plugged into the ESQ-M Cartridge slot. When there is no Cartridge in the slot, only Programs 001 through 040 can be selected.

SELECTING A PROGRAM

To select a different Program, move the Data Entry Slider or press the Up and Down Arrow buttons. As you do so, the name and the Program Number showing on the Display will change to reflect those of the new sound that you have selected.

Note that Cartridge sounds are not treated any differently from Internal sounds. When a Cartridge is inserted, the Data Entry Slider and the Up and Down Arrow buttons will continuously move through all 120 Programs without differentiating between the Internal and Cartridge sounds

Another way to select a Program on the ESQ-M is to enter its Program Number directly from the Control Keypad. You must enter all three digits of the number, including the leading zeroes in numbers below 100. For example:

- to select Program # 3, enter 0-0-3
- to select Program # 42, enter 0-4-2
- to select Program # 105, enter 1-0-5

and so on. There is a timer function at work when you enter Program Numbers directly — after you enter a valid digit, the ESQ-M waits two seconds for you to enter another valid digit. If you don't, it goes back to the original program. If this happens to you, don't get flustered— just enter the Program Number again.

CHANGING PROGRAMS REMOTELY

To select a new ESQ-M sound from your master keyboard simply select a new patch from its front panel. This will send a MIDI Program Change command, instructing the ESQ-M to change to the designated sound. Different instruments have different methods for numbering their Programs — see the note below.

Some instruments have access to less than 120 Programs, and therefore cannot send the full 120 Program changes that the ESQ-M will recognize. You can only send the ESQ-M Program Change numbers as high as your master keyboard is capable of transmitting. So with some instruments as a master, you will not be able to remotely select all of the ESQ-M's Programs.

Some instruments, on the other hand, send the full 128 Program Changes available through MIDI. The **ESQ-M** will ignore Program Changes over 120.

A NOTE ABOUT PROGRAM NUMBERS

MIDI Program Numbers can be a little confusing. On the ESQ-M (and the ESQ-1) you will find the Programs numbered from 1 to 120. Several other synths, including the DX-7, also begin numbering from Program Number 1.

True MIDI Program Numbers, the numbers actually sent and received by MIDI instruments, begin at Program Number 0. (Computers, unlike people, tend to number things starting from zero instead of one.) So ESQ-M Program Number **001** actually corresponds to True MIDI Program Number **zero (0)**. **ESQ-M** Program Number 120 corresponds to True MIDI Program Number **119**. And so on. The Program Number shown on the ESQ-M is the True MIDI Program Number plus one. Some instruments reference their Programs starting from #0, some starting from #1. Hence the confusion.

The trick to keeping things straight is this: if the instrument you use with the ESQ-M lists Program Numbers beginning from #0, you will have to add 1 to the Program Numbers on that instrument to come up with the corresponding ESQ-M Program Number. If the instrument lists Program Numbers beginning from #1, any Program Number on that instrument will be the same as the corresponding ESQ-M Program Number.

WHEN YOU REMOVE THE CARTRIDGE

The ESQ-M remembers which sound you had selected for each Track, even if it's a Cartridge sound and you remove the Cartridge. If you remove the Cartridge when a Cartridge sound (# 041 to 120) is selected, the Program Name on the Program Page is replaced by the word *CART*, indicating that a Cartridge Program is selected but no Cartridge is present. The Program Number will still reflect the Cartridge location. If you reinsert the Cartridge, the proper Program name will reappear, and all will be as it was.

The sound you hear while the Cartridge is removed will be that of the Internal sound which occupies the same relative memory location in the Internal memory that the selected sound does in the absent Cartridge. Subtract 40 (for CART A sounds) or 80 (for CART B sounds) from the Program Number showing on the Display to arrive at the number of the Internal Program that you will hear. For example, if Program # 042 is selected, and you remove the Program Cartridge, the Display will read:

TRK 0 *CART* 042

The Program that you will actually hear playing (until you re-insert the Cartridge or change Programs) will be Program # 002.

BATTERY MAINTENANCE

The reason that the ESQ-M "remembers" Programs and other parameters when the power is OFF is that all of its Internal RAM (Random Access Memory) is "Battery Backed-up". The battery that keeps the ESQ-M's Memory intact is located inside the ESQ-M, and when it becomes discharged, it must be replaced by an authorized ENSONIQ Repair Station.

The battery that came in your ESQ-M is good for up to ten years of life. You will know when it needs replacing, because the ESQ-M will tell you so. One day you will switch the Power ON, and instead of its usual wake-up message, the Display will read:

BATTERY VOLT LOW

meaning, of course that the Battery voltage is low. When this message appears, you should make sure that all Programs are saved to a Cartridge or computer librarian, and then take the ESQ-M to an authorized ENSONIQ Repair Station as soon as possible to have the battery replaced.

You can check the status of the battery on the **Analog Test** Page, which is one of the "hidden" functions on the **Storage** Page (see p. 90). When the battery is in good shape the Display will read "**B=00**" on the **Analog Test** Page. Any reading above **00** indicates a battery that is on the way out, and will need replacing very soon.

RACK MOUNTING THE ESQ-M

The ESQ-M can be rack mounted in a standard 19" audio rack by installing the rack mount hardware included with the unit. To mount the ESQ-M in a rack:

1. Fasten the rack mount "ears" to the sides of the front panel with the supplied screws, making sure that the oval mounting holes face the front of the unit.
2. The ESQ-M occupies two standard rack spaces (3 1/2"). We recommend the use of nylon washers when rack mounting any unit.
3. If you are installing another piece of equipment directly below the ESQ-M in your rack, it may be necessary to remove the rubber feet from the underside of the cabinet.

Section 3 — Getting In Deeper

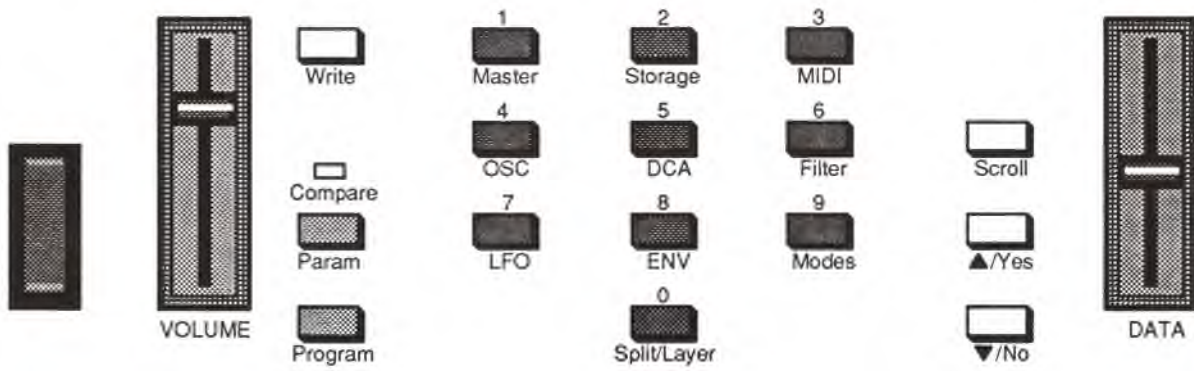

PROGRAM MODE — Changing Programs and Tracks

The ESQ-M is always in one of two modes – **Program Mode** or **Parameter Mode**. These modes are entered by pressing either the **Program** or the **Param** button on the front panel.

When you press the Program button, the display will show :

- 1) which of the nine Tracks is currently selected,
- 2) the name of the Program currently playing on that Track, and
- 3) the Number of that Program

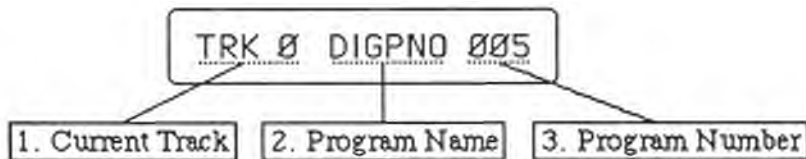

In Program Mode, there are only two things you can do:

- 1) change the Program which is playing on the Track, or
- 2) select a different Track.

CHANGING PROGRAMS

To change to a new Program, first press the Program button to make sure the ESQ-M is in Program mode. You now have a number of ways to select a new Program.

- **Press the Up Arrow/Yes or Down Arrow/No buttons** to step through the Programs in memory one at a time.
- **Move the Data Entry Slider** to zip through the programs more quickly.
- If you know the number of the Program you want, you can **enter it directly from the Control Keypad**. You must enter all three numbers, including the zero for numbers smaller than 100 (such as "0-3-5" for Program #35, etc.) If a Program Cartridge is inserted, Programs # 001 through 120 are available to be selected. If no cartridge is inserted, ONLY Programs # 001 through 040 are available.

TRACK 0

In most cases, when using the ESQ-M like a normal synthesizer, it's just as well to leave it on Track 0, and ignore the other eight. (By "normal" we mean a unit that is simply played from some master controller, one patch at a time.) The other eight Tracks are there primarily as a way to get at different sounds simultaneously when using the ESQ-M with a sequencer, guitar controller, "smart" keyboard controller, or any other device which is capable of sending on several MIDI Channels at once.

If you use the ESQ-M in OMNI or POLY modes, there is little reason to stray from Track 0 — in OMNI or POLY modes only one Track (the selected Track) responds to MIDI data at any time. So changing Tracks doesn't make much difference, since in OMNI or POLY mode Track 1 will behave exactly like Track 0, as will Track 2, Track 3, and so on.

As it comes out of the box, your ESQ-M will be in OMNI mode — that is, it will respond to all enabled data coming in on any MIDI Channel. This is fine if it's the only remote MIDI instrument you'll be using. If there are others, you will probably want to go to the MIDI Page and select POLY mode. In POLY mode the ESQ-M will respond only to data coming in on the Base MIDI Channel (which you also select on the MIDI Page). See the section "**MIDI Page**" for details on selecting MIDI mode and MIDI Channel.

CHANGING TRACKS

To select a different Track, **press the Scroll button**, and the ESQ-M will advance to the next higher Track. The display will now show the number of the new Track, along with the Program on that Track and its Program Number. If the ESQ-M is in OMNI or POLY Mode, the sound you hear will change to that of the new Track (this is not the case in MULTI or MONO Modes).

To scroll backwards, that is to go back to the next lowest Track, **press the Scroll button and hold it down while pressing the Down Arrow/No button**. (This works when using the Scroll button in any mode – pressing Scroll scrolls forward, and pressing Down Arrow/No while holding down the Scroll button scrolls backward.)

If you continue pressing Scroll, the ESQ-M will continue advancing to the next Track. When it reaches Track 8 (the highest numbered Track), pressing Scroll brings you back to Track 0.

MORE ABOUT TRACKS

When things really get interesting is when you put the ESQ-M into MULTI mode. MULTI mode is an ENSONIQ innovation which allows the ESQ-M to respond to *nine* different MIDI Channels at one time. This is where the Tracks come in. More detail on using the ESQ-M's multi-timbral capabilities in specific applications is available in other sections of this manual. Here we'll just cover some of the basics.

Imagine This:

Imagine nine synthesizers, each receiving on a different MIDI Channel, each totally independent, capable of receiving key information, Program Changes and controllers (pitch bend, MOD wheel, etc.). Now here's the tricky part: these nine synthesizers share a pool of eight voices.

The eight voices are *dynamically assigned*. That means that when one of the nine synths needs one, or two, or five (or even all eight) voices, it gets them. When it's through with a voice, it puts it back in the pool, where the voice is again available for any of the nine synths. If one of the synths needs to play a note when all eight voices are already in use, it will "steal" the voice that has been playing the longest — the oldest note.

Obviously, all nine synths cannot be playing at one instant in time. At any one instant, only eight voices can be playing, but those eight voices can be playing any combination of sounds from any of the nine synths.

The scenario above exactly describes the behavior of the nine Tracks of the ESQ-M in MULTI mode. In MULTI mode each Track acts like a separate synthesizer, with its own:

- Program
- Program number
- MIDI Channel
- Mix level

Each track will receive independently on its own MIDI Channel. So you can send into the ESQ-M on MIDI Channel 1 and get the Program on Track 0; send on MIDI Channel 2 and get the Program on Track 1; send on MIDI Channel 3 and get the Program on Track 2, and so on. All at the same time. See the diagram on the next page.

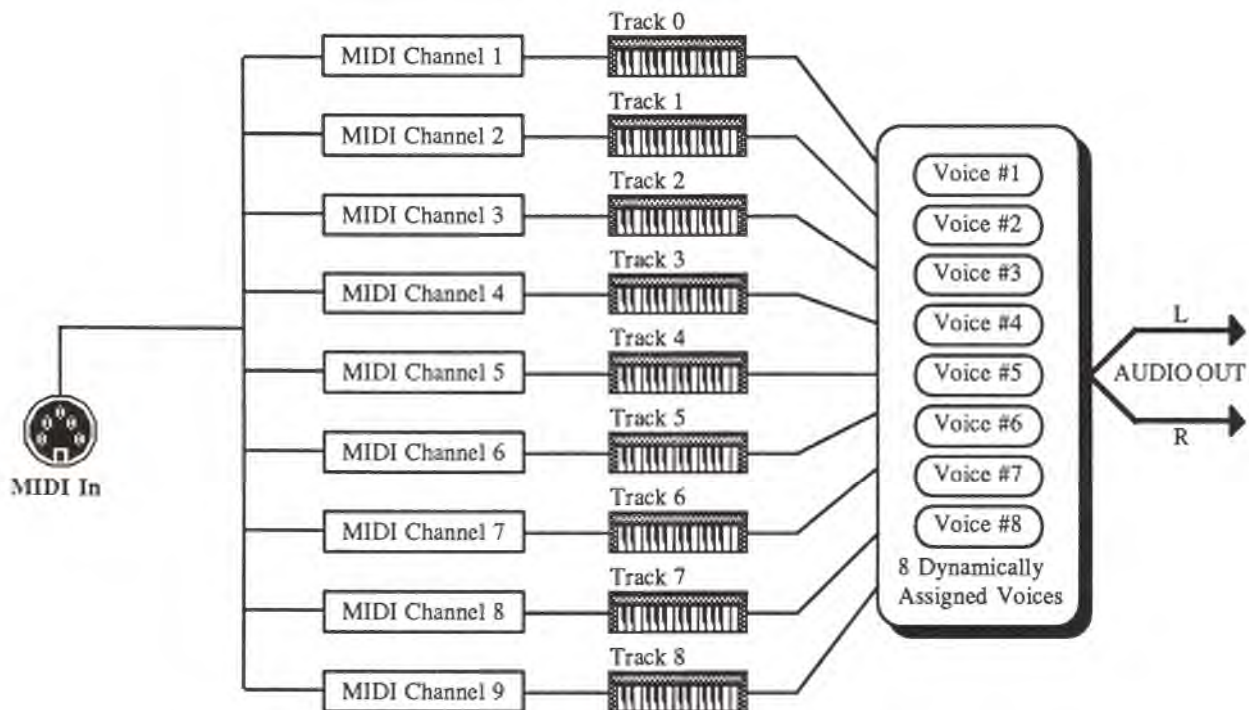

The above picture illustrates the concept of the ESQ-M as nine "virtual" synthesizers: each Track as a separate, independent synth, receiving on its own MIDI Channel, with all nine Tracks sharing a pool of eight dynamically assigned voices. This illustration shows Track 0 receiving on MIDI Channel 1, Track 1 receiving on MIDI Channel 2, Track 2 receiving on MIDI Channel 3, and so on. These are the default values — how the MIDI Channels are assigned as the ESQ-M comes out of the box. You can, of course change the MIDI Channel of each Track, and whatever values you select will be remembered by the ESQ-M, even when the power is Off. See the Section on the **MIDI Page** (p. 32) for more details.

PARAMETER MODE

ABOUT PARAMETRIC PROGRAMMING

To modify or "edit" Programs, the ESQ-M uses a method known as **parametric programming**. You may well have already encountered some form of parametric programming on other synthesizers. What this means is that instead of having a separate knob or Slider for each function, you have one master Data Entry Slider and two buttons which adjust the value of whichever parameter you select.

The 16 character display shows you one parameter, or variable, at a time. Oscillator Pitch, Master Tuning, MIDI Channel and Filter Cutoff Frequency are all examples of parameters which can be selected and modified. Whichever parameter is showing on the display at any given time is considered the *current parameter*, the one whose value will be modified if you move the Data Entry Slider or press the Up and Down Arrow buttons.

This approach has many advantages, the most obvious of which is that it greatly reduces the amount of hardware-- knobs, switches, sliders, etc.-- needed to control a wide variety of functions. (If the ESQ-M had a separate control for each function, it would literally have hundreds of knobs, buttons, switches and such.)

PAGES

Parameters on the ESQ-M are organized into **Pages**. Each Page is really just a collection of parameters related to some function, such as the pitch of each oscillator, the volume of each oscillator, the filter frequency, etc. On the ESQ-1 with its larger display, all the parameters on a given Page are displayed at once when you select that Page. On the ESQ-M when you select a Page you see one parameter at a time and use the Scroll button to advance to the next parameter on the Page.

You can think of the ESQ-M in relation to a book -- when the ESQ-M is in Parameter mode, each time you press one of the buttons on the Control Keypad, you are in effect "turning to" that function's Page. The name of the Page appears in the left side of the display. Once you have turned to the Page you want, the Display shows you the parameter which was last selected on that Page. You can now Scroll to the Parameter you want to adjust, and change its value using the Data Entry Slider and the Up and Down Arrow buttons.

THE PARAM BUTTON

Pressing the Param Button puts the ESQ-M into Parameter Mode. In Parameter Mode, the ESQ-M displays, and lets you adjust, one parameter at a time. When you press the Parameter button, the display will show:

- 1) the name of the current Page
- 2) the name of the current parameter, and
- 3) the value of the current parameter

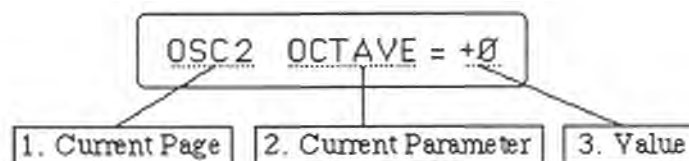

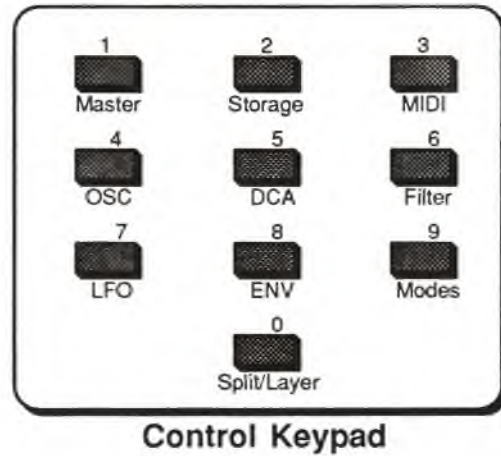

THE CONTROL KEYPAD

In Parameter Mode, the 10 buttons of the Control Keypad serve multiple functions. You'll notice that each button has a Page name as well as a number. These buttons allow you to select any of the Programming or Global Pages, and to then go directly to any parameter on the Page.

SELECTING A PAGE

To select to a new Page, first press the **Param** button to make sure the ESQ-M is in Parameter mode. The display will show the currently selected Page and Parameter, as illustrated previously. To select a different Page, press the button directly above the Page Name.

To select the **Master, Storage, MIDI, Filter, Modes,** or Split/Layer Page, press the button above its name and the Page is selected. The Page name will show on the left side of the display, the current parameter in the middle, the current value of that parameter on the right.

The **OSC, DCA, LFO** and ENV buttons each serve to select more than one Page. (This is because the ESQ-M has three Oscillators, four DCA's, three LFO's and four Envelopes per voice.) When you press any of these four buttons in Parameter mode, you will be prompted to enter a second number, telling the ESQ-M *which* Oscillator, DCA, LFO or Envelope you want to select.

For example, suppose you want to go to the OSC 2 Page. First press the Param button. Then press the Control Keypad button above OSC. The display will flash the message:



Now press 2. This selects the OSC 2 Page. When you press **OSC, DCA, LFO** or ENV, the ESQ-M waits, flashing the question mark, for about 2 seconds. If you press a valid number within that time, it selects the proper Page. If you don't, it will return, after 2 seconds, to wherever it was previously. (If you didn't select the number in time, and the Display reverted to the Page it was previously on, don't panic. Just let a few seconds pass, and try again.)

SELECTING A PARAMETER

Once you have gotten to the Page you want, the Display will show the last-used parameter on that Page (it remembers which parameter was last selected for each Page). There are two ways to select a different parameter:

1. **Press Scroll.** Pressing the Scroll button will advance to the next parameter on the Page. Again, you can press the No/Down Arrow button *while holding down the Scroll button* to scroll backwards through the parameters. Or,
2. **Enter the Parameter number directly after selecting the Page.** Each parameter on each Page has a number associated with it. After you select a Page, if you immediately press the number of the parameter you want, the ESQ-M will go directly to that parameter.

Page
Missing

Page
Missing

THE EDIT BUFFER & THE EDIT PROGRAM

You can edit a Program, while keeping the original Program intact, because the edited version is kept in a special area of Memory called the **Edit Buffer**. Whenever you change any parameter of a Program, the altered Program is put in the Edit Buffer, replacing whatever was previously there. Only one Program at a time can reside there — the Edit Buffer always contains the results of your last edit.

If you like the results of the changes you have made to a Program, you should rename it and save the new Program permanently, to another Location. The procedure for this is covered in Section 5.

When you press the **Param** Button to toggle the Compare light on and off, what you are doing is alternating between the Program in the original Memory Location and the Program in the Edit Buffer. We refer to the Program in the Edit Buffer as the **Edit Program**.

You can return to the Edit Program, even after selecting another Program (as long as you don't change any parameters there) by pressing the **Compare** Button. This puts you back in the Edit Buffer, and any changes you make will affect the Edit Program.

The rule of thumb is this: **Whatever Sound you hear, that's what you're editing.**

*Page
Intentionally
Left Blank*

Section 3 — "Global" Functions

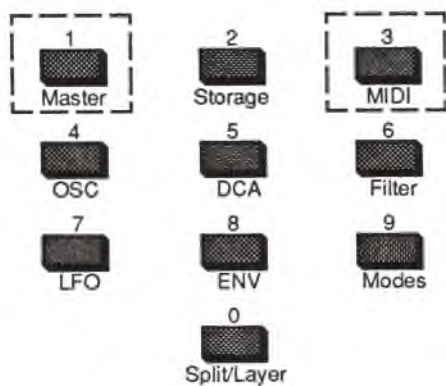

[MSTR] MASTER PAGE

Controls Master Tuning, Velocity Sensitivity, Pedal Function and Pitch Bend

The parameters on this page are keyboard-wide, or "Global." The settings here will not change with different Programs selected, but will remain in effect for whatever Program you are playing.

Aside from Master Tuning and overall Velocity Sensitivity, this page also contains a control for selecting between Pitch Bend Modes — normal operation, where the Bend Wheel affects all notes; and a special "Held" mode in which the Pitch bends only affect those keys which are being held down.

Use this Page to:

- Adjust the **Master Tuning** of the keyboard;
- Adjust the overall **Velocity Sensitivity** of the Instrument;
- Select whether the **Foot Pedal** will act as a Modulator or a Volume Pedal;
- Set the range of the **Pitch Bend Wheel**; and
- Select a **Pitch Bend Type**.

MASTER PAGE		Parameters on this Page:		
0	1	2	3	4
TUNING	VEL SEN	PEDAL	BND RNG	BND TYP

0. TUNE — Master Tune Adjust

Tunes the Keyboard to the desired Pitch. A setting of **TUNE= +00** will yield Concert **A=440** tuning. The total range of this control is about a half step (semitone) up or down.
 Range: **-31 To +31**.

1. VELSEN — Velocity Sensitivity Adjust

This parameter determines the responsiveness of all Velocity-related parameters on the ESQ-M. You can adjust it to suit your own touch — that is, how hard you play — as well as adjusting for the response of the master keyboard you are using. Of course, if you play the ESQ-M from a controller which does not transmit key velocity, this parameter will have no effect.

The three available settings are:

----> **SOFT** — This is for someone with a light touch. On this setting, a minimum of force is required to reach the maximum level of any Velocity-controlled parameter.

----> **MED** — Medium sensitivity. This setting should be right for the player with an average touch.

----> **HARD** — This setting is for the player who really digs in. It provides the widest possible range of velocity sensitivity.

2. PEDAL — Pedal Function Select

The setting of this parameter determines whether a **SW-10** Foot Pedal plugged into the **PEDAL/CV** jack in the ESQ-M's rear panel will act as a Modulator or as a Volume Pedal. Note that this only affects a Pedal plugged into the ESQ-M itself. The setting of this control has no effect on incoming MIDI Foot Pedal (controller #4) or Volume (controller #7) information. There are two possible states:

----> **PEDAL=MOD** — This is the default value. When **PEDAL=MOD**, the Foot Pedal will act as a Modulator in the Voice section of the **ESQ-M** and will have an effect on the sound when **PEDAL** is selected as a Modulator.

----> **PEDAL=VOL** — When PEDAL=VOL the Foot Pedal will adjust the volume of the current Track. Moving the Pedal will have the same effect as adjusting the **MIX Level** on the MIDI Page. Only the current Track will be affected — only one Tracks volume can be adjusted at a time.

3. BEND RANGE — Pitch Bend Wheel Range

Adjusts how far incoming Pitch Bend information (transmitted by the Pitch Bend Wheel on most keyboards) will bend a note Up or Down. Each increment represents a Semitone. Total range is one octave up an down.

Range: 0 To 12.

4. BNDTYP — Pitch Bend Type (or mode) Selects between two modes of operation for the Pitch Bend Wheel. There are two Modes:

ALL — Moving the Pitch Bend Wheel will affect the pitch of all notes that are being played. This is how most Pitch Wheels usually operate.

HELD — In this Mode, only those keys that are being held down when you move the Pitch Wheel will be affected by the wheel. Keys that have been released will not bend, even if they are being sustained by holding down the Sustain Foot Switch. This enables you to bend certain notes while others remain unchanged in pitch. With a little practice you can simulate guitar and pedal steel-type techniques, and many other interesting effects.

Note that the ESQ-M must be enabled (on the MIDI Page) to receive Controllers, or else parameters 3 and 4 will have no effect, as Pitch Bend information will not be recognized. See the following section for details on the MIDI Page.

[MIDI] MIDI PAGE

Controls the ESQ-M's MIDI Configuration

From this Page you define the MIDI (Musical Instrument Digital Interface) configuration of the ESQ-M. Because of its multi-timbral capabilities, the MIDI implementation of the ESQ-M is a bit more involved than many synthesizers, so we advise that you read this section carefully, particularly if you will be using the ESQ-M with a sequencer, guitar controller, or in some other multi-timbral application.

Use this Page to:

- Turn On or Off the **MIDI Overflow Mode**;
- Select an **External Controller** to be used as a Modulator;
- Enable **Pressure** (After-touch) as an Modulator;
- Select a **MIDI Mode**;
- Determine which types of information will be received over MIDI by the ESQ-M;
- Select a different Track;
- Select a **Base MIDI Channel**, and/or a MIDI Channel for each Track;
- Change the **Program** that is on the current Track; and
- Set the **Mix Level** for the current Track.

MIDI PAGE		Parameters on this Page:						
0	1	2	3	4	5	6	7	8
OVERFLO	XCONTROL	PRESSR	MODE	ENABL	TRACK	CHAN	PROG	MIX

0. OVERFLO — MIDI Overflow Mode

MIDI Overflow Mode is a unique feature of the ESQ-1 and the ESQ-M that allows two units connected together by MIDI to act like a single 16 Voice synthesizer. You most likely won't be using Overflow on the ESQ-M unless you have two of them. A more practical use of Overflow arises if you have an ESQ-1 driving an ESQ-M. When you turn on Overflow at the ESQ-1, it will send out via MIDI any notes that are played after all eight of its voices are busy (it won't "steal" voices). The ESQ-M can then play those extra notes, and assuming that both units have the same Programs in the right places and the MIDI Channels line up, the ESQ-1 and the ESQ-M can function together as a single sixteen-voice synthesizer. Two (or more) ESQ-M's connected together via MIDI will work the same way.

When OFF: The ESQ-M will behave normally, sending and receiving all enabled MIDI data.

When ON: The ESQ-M (or ESQ-1) will send out no MIDI data until all eight Voices are playing, and another key is struck. At this point, instead of "stealing" a Voice to play the new note, it sends that note out over MIDI. It will continue sending notes out MIDI until there is an internal Voice available to play a note. This allows the remote unit to play the notes that the master unit can't. The remote unit must be on the same MIDI Channel, and must be playing the same Program for this to be effective.

Note that Overflow Mode will work exactly the same way with any other synth set up to receive MIDI Data from the ESQ. However, the effect of a different synth, with a different patch, picking up and playing whenever the ESQ runs out of voices will be unpredictable at best.

A more detailed look at the uses of MIDI Overflow Mode can be found in Section 6.

A CAUTIONARY NOTE: DO NOT accidentally turn On the Overflow Mode and then forget about it. Here's what will happen if you do: you will be merrily playing along, and you will suddenly notice that the ESQ-M seems to be "losing voices" — you will occasionally play

notes and they simply won't sound. You won't know why this is happening, and will assume your ESQ-M is broken. The problem is that if Overflow mode is left on, the ESQ-M will send excess notes out via MIDI instead of playing them. The solution is to turn Overflow Off. So save yourself some aggravation. Be sure not to leave MIDI Overflow On after you are through exploring the parameters on this Page.

1. XCONTROL — Select External Controller

One of the Modulators that can be selected in the Programming section of the ESQ-M is XCTRL — External Controller. Each Controller on a Synthesizer (Breath Controller, MOD Wheel, or Data Entry Slider, for example) has a standardized MIDI Controller number, which is the number you select here to make a particular Controller a Modulator in any of your Programs.

Note that this parameter is "Global" — that is, only one controller can be active here at a time. However, you don't have to use this parameter to enable the ESQ-M to receive the Foot Pedal, MOD Wheel, or Pressure (After-touch). Those three controllers are available separately as modulators. Also MIDI Volume (MIDI Controller #7) is received by the ESQ-M without your having to enable it here. This parameter is to allow you to program an additional controller, such as Breath Controller or Data Entry Slider, into your sounds.

Let's say that you are driving the ESQ-M from a keyboard with a Breath Controller. You can set up a Program on the ESQ-M where the **Filter Cutoff Frequency**, or some other Manual Level, is modulated by XCTRL. Then assign this parameter a value of **XCONTROL. 02**. The Breath Controller will now modulate the **Filter**, or whatever, on this Program. The chart below lists the accepted MIDI Controller numbers. The following Controller Numbers have been agreed upon:

Number	Controller	Number	Controller
1	Modulation Wheel	66	Sostenuto Pedal
2	Breath Controller	92	Tremolo
4	Foot Pedal Controller	93	Chorus
6	Data Entry Slider	94	Celeste
7	Volume Pedal	95	Phaser

Though the range of this Control is from **01** to 95, most of the values other than those listed above have no accepted function, as yet. They are there to accommodate future MIDI standards.

NOTE: If you wish to Program the Foot Pedal as a modulator in an ESQ-M Program, you should select PEDAL as the modulator, rather than XCTRL.

2. PRESSR — Pressure (After-touch) Select

Pressure (also called After-touch) is sent by certain synthesizers and Keyboard Controllers. The **ESQ-M** can receive Pressure via MIDI from those keyboards which send it. There are two types of Pressure — **Channel Pressure** and **Key Pressure**. When **Pressure** is enabled here, it can be used as a modulator on any of the the Programming Pages. This control has three possible states:

- > **PRESSR=OFF** — The ESQ-M will not receive any Pressure information. All such information will be ignored.
- > **PRESSR=CHAN** — This enables the ESQ-M to receive the most common type of Pressure — **Channel Pressure**. With Channel Pressure, after a note is played, pressing down harder on the key modulates every note currently playing. Like a MOD Wheel, Channel Pressure is "Global" — it affects the entire keyboard when activated.
- > **PRESSR=KEY** — This enables the **ESQ-M** to receive another type of Pressure — **Key Pressure**. Key Pressure (also called Polyphonic Pressure) only modulates the note that is pressed — all others remain unmodulated.

You should consult the Manual of the MIDI instrument you will be using in conjunction with the ESQ-M to see which, if any, type of Pressure it sends.

3. **MODE — Select MIDI Mode**

The **MIDI Mode** determines how MIDI information will be received by the nine Tracks of the ESQ-M. It is very important to understand these four modes — they are the key to unlocking the multi-timbral possibilities of the ESQ-M. Note that the behavior of the **MIDI Channel** parameter (BASECHAN or CHAN) changes depending on which MIDI Mode the ESQ-M is in. There are four **MIDI Modes** that can be selected here:

OMNI — In **OMNI Mode** whichever Track is selected responds to information (keys, controllers, Program Changes, etc.) received on any of the sixteen MIDI channels. (Remember, the selected Track is the one whose number appears to the left of the Display when you press the **Program** button.) OMNI mode is a good choice if the ESQ-M is the only MIDI instrument you will be driving, and you only need one sound at a time.

OMNI is the default mode: when it first comes out of the box, or after the memory is re-initialized, the ESQ-M will be in OMNI mode. You'll have to select a different mode to use the ESQ-M in any but the simplest set-ups. Once you change the mode, the ESQ-M remains in the new mode until you change it again, even when you turn it off.

POLY — In **POLY Mode** whichever Track is selected responds to information (keys, controllers, Program Changes, etc.) received only on the Base MIDI Channel (see #6 below). Midi information on all other channels will be ignored.

POLY Mode is a good choice if you are using the ESQ-M with other MIDI instruments and want to assign it its own MIDI Channel, but you only need one sound at a time out of the **ESQ-M**.

MULTI — **MULTI Mode** is an ENSONIQ innovation which was specially designed to make optimal use of the multi-timbral capabilities of the ESQ-1 and the **ESQ-M**. **MULTI Mode** is the mode in which the ESQ-M becomes nine "virtual synthesizers." In **MULTI Mode** each of the nine Tracks can receive MIDI information independently on a different MIDI Channel.

Track 0 will always receive (and send) on the Base MIDI Channel. Tracks 1 through 8 will each receive (and send) on their own selected Channels. (See **BASECHAN/CHAN** below.)

Different MIDI Channels should be selected for each Track! If the same MIDI Channel is selected for two Tracks, priority is given first to the lowest numbered Track that shares the Channel. Higher-numbered Tracks that share the same Channel will not receive anything. For example:

If MIDI Channel 1 is selected as the Base Channel for Track 0, and Channel 1 is also selected for Tracks 1 and 3, Track 0 will respond to information on Channel 1, and Tracks 1 and 3 will receive nothing. Or;

If MIDI Channel 6 is selected for Tracks 2, 4, and 7, then Track 2 will receive on Channel 6, and Tracks 4 and 7 will receive nothing.

You can use this fact to your advantage. Suppose you only want to use four Tracks on four MIDI Channels, and have the rest of the Tracks ignore all MIDI information. Set Tracks 0 through 3 to receive on the desired Channels, and then set Tracks 4 through eight to the same Channel you selected for the Base Channel. All information received on the base Channel will be "intercepted" by Track 0. Tracks 4 through 8 will not play.

----> **MONO** — Before **MULTI Mode** was developed, **MONO Mode** was about the only way to have a poly-timbral synthesizer. It is particularly useful for driving the ESQ-M from a Guitar Controller, or any other application where having up to eight independent, monophonic, Channels is desirable. MONO Mode assigns one voice per Track per MIDI Channel.

When **MONO Mode** is selected:

- a) Track 0 does not receive any MIDI information at all. It "ceases to exist" as a MIDI receiver.
- b) Track 1 will receive on the **Base MIDI Channel** selected on this Page (see #6 below). Track 2 will receive on the next higher Channel, Track 3 on the next, and so on. The Base Channel cannot have a value greater than nine.

The chart below shows the MIDI channels that will be received by the eight Tracks, in **MONO Mode**, for the possible Base Channels:

If Base Channel=	1	2	3	4	5	6	7	8	9
Track 1 receives on	1	2	3	4	5	6	7	8	9
Track 2 "_____"	2	3	4	5	6	7	8	9	10
Track 3 "_____"	3	4	5	6	7	8	9	10	11
Track 4 "_____"	4	5	6	7	8	9	10	11	12
Track 5 "_____"	5	6	7	8	9	10	11	12	13
Track 6 "_____"	6	7	8	9	10	11	12	13	14
Track 7 "_____"	7	8	9	10	11	12	13	14	15
Track 8 "_____"	8	9	10	11	12	13	14	15	16

- c) The Base Channel Minus One becomes a global MIDI Channel for Controllers (Pitch bend, Pressure, MOD Wheel, etc.). If the Base Channel is Chan. 3, any Controllers received on Chan. 2 will affect All the Tracks. If the Base Channel is Chan. 1, Chan. 16 becomes the Global Channel for Controllers.

On a guitar synth, for example, each string could be assigned to send on its own Channel, and would play on the ESQ-M Track assigned to that Channel. Pitch bends sent by an individual string on its own MIDI Channel would affect only that string's Track. The "whammy bar" could be assigned to send pitch bends on the Base-Channel-minus-1, and would affect all the Tracks. In this way you can more accurately reproduce the control parameters of a real guitar. (Consult the manual of your guitar controller to see if it can send controllers on different MIDI Channels.)

4. ENBL — MIDI Enables

This parameter determines what kinds of MIDI information will be sent and received by the ESQ-M. There are four possible states for this parameter:

----> **KEYS — Key Events Only**

In this state the ESQ-M will send and receive only notes that are played on the Keyboard. Controllers (such as MOD Wheel, Pitch Bend, etc.), Program changes, and Parameter Changes will not be sent or received.

----> **KY + CTR — Keys and Controllers**

Key Events and Controllers (MOD Wheel, Pitch Bend, etc.) only will be received. Parameter Changes will be sent, but not received. Program changes will not be sent or received.

----> **K + C + PC — Keys, Controllers and Program Changes**

Key Events, Controllers, and Program Changes will be received in this Mode. This means that Program changes sent by the master keyboard (or other controller) will cause the ESQ-M to change to the same-numbered Program. (Changing Programs on the ESQ-M will cause it to send a Program Change on the current Track's MIDI Channel, unit to change to the same numbered Program; Again, Parameter Changes are sent but not received.

KCPSYS — Keys, Controllers, Program Changes and System Exclusives

Key Events, Controllers, Program Changes and System Exclusive messages will all be received via MIDI in this Mode. This enables the ESQ-M to receive System Exclusive messages, such as Parameter selects, Parameter Changes, Program Dumps, etc. In this state the ESQ-M can be programmed from an ESQ-1 — any parameter you select and modify on the ESQ-1 will be selected and modified on the **ESQ-M** (except for those on the MIDI Page).

In this State you can also program the ESQ-M from a computer (with the proper software) or send and receive Programs between the ESQ-M and a computer using any of the Librarian Programs available. Patch Librarian programs designed for the ESQ-1 are fully compatible with the ESQ-M (at least those distributed by ENSONIQ are).

A few notes about System Exclusives:

- After performing a Program Dump or doing some remote programming, you should take care not to leave System Exclusive messages enabled when returning to normal operation. Change the setting of this parameter back to **[ENBL=K + C + PC]**. Otherwise you may find that the ESQ-M is still responding to the Data Entry Slider and the Inc/Dec buttons of your master keyboard by more or less randomly changing Programs, parameter values, etc. This can be bad for one's mental health and should be avoided.
- For the same reason, this parameter is one of the very few on the ESQ-M whose value is not preserved exactly when the ESQ-M is turned Off and then On again. If System Exclusive messages are enabled **[ENBL=KCPSYS]** when the unit is turned Off, when you next turn it back on this parameter will be reset to Keys, Controllers and Program Changes **[ENBL=K+C+ PC]**. If you want to enable System Exclusives after powering up, you must select and change this parameter accordingly.

5. TRACK — Current Track

This parameter allows you to change the current Track from within the MIDI Page. Changing the Track here has exactly the same effect as changing Tracks on the **Program** Page (by pressing **Scroll**). A Track change made here will be reflected on the Program Page, and vice versa.

This parameter is very useful when you are setting up MIDI Channels, Programs and Mix levels for several Tracks. You can use this parameter to change to a new Track without having to exit the MIDI Page.

6. BASECHAN (or CHAN) — MIDI Channel

This parameter determines which MIDI Channel (or MIDI Channels) the ESQ-M will receive (and send) on. The appearance of this parameter can change depending on which MIDI Mode is selected (see #3 above) and which Track is the current Track.

In OMNI or POLY Mode: This parameter will always read "BASECHAN= ", no matter which Track is the current Track. This indicates that the MIDI Channel showing on the Display is the **Base Channel**.

- In OMNI Mode the current Track (whichever Track is selected) will receive on any Channel; any data sent by the ESQ-M (Program Changes, Controllers, etc.) will be sent on the Base Channel.
- In POLY Mode the current Track (whichever Track is selected) will receive only on the Base Channel; any data sent by the ESQ-M will be sent on the Base Channel.
- Any of the sixteen MIDI Channels may be selected to be the Base Channel.

Range: 01 To 16.

----> In MULTI Mode:

- When Track 0 is selected, the Display will show "BASECHAN= ". Track 0 will always send and receive MIDI information on the Base Channel, except in MONO Mode. In MULTI Mode, Track 0 gets priority on the Base Channel — any other Track set to the same Channel as

the Base Channel will receive nothing. •

- When any of the other Tracks (1-8) is selected, the Display will show the current Track (indicated as **T1**, **T2**, **T3**, etc.) and the Channel assigned to that Track (indicated as CHAN. _) Thus if Track 2 is the current Track, and it is set to MIDI Channel 3, the Display for this parameter would look like this:

MIDI T2 CHAN =03

You can set any Track to receive on any Channel, but bear in mind that only one Track can receive on any one Channel. If more than one Track is set to the same Channel, the lowest-numbered Track will receive on that Channel and higher-numbered Tracks will receive nothing. Any of the sixteen MIDI Channels may be selected for any Track. Range: 01 To 16.

Once you assign a MIDI Channel to each Track in MULTI mode, these Channel assignments are remembered by the ESQ-M, even though they are not visible when a different Mode is selected. So even though the Tracks are automatically re-assigned new channel numbers when you select MONO Mode, once you go back to MULTI mode the channel assignments will be just as you left them. The only exception is the Base Channel, which can be changed in any of the four modes, though it performs a slightly different role in each mode. See the "note about the Base Channel" below.

Note that in MULTI mode any System Exclusive messages (Program Dumps, etc.) will be sent and received on the Base Channel (Track 0's Channel).

In MONO Mode:

- As noted earlier (see #3 above), in MONO mode Track 0 ceases to function as a MIDI receiver. If Track 0 is selected, the Display will read "CHAN=UNUSED. "
- Track 1 receives on the Base Channel. Accordingly, when Track 1 is the current Track, the Display will show "BASECHAN= . " In MONO Mode you can only adjust the MIDI Channel when Track 1 is selected — the MIDI Channels for Tracks 2-8 are set automatically based on what the Base Channel is set to. (See #3 above for a chart of MIDI Channel assignments in MONO Mode. Only MIDI Channels 1 through 9 may be selected for the Base Channel. Range: 01 To 09.)
- When Tracks 2 through 8 are selected, the Display for this parameter will appear the same as when the ESQ-M is in MULTI Mode — it will show the current Track (indicated as **T2 T3 T4**, etc.) and the Channel assigned to that Track (indicated as **CHAN. _**). The difference is that in MONO Mode you cannot change that Channel from here. It is displayed for informational purposes only.

A NOTE ABOUT THE BASE CHANNEL: Despite the way it sort of bounces around from Mode to Mode, once the Base Channel is set to a certain number it stays there, even after you select a different MIDI Mode. It's just that in different MIDI Modes, the Base Channel is sometimes associated with a different Track (or Tracks).

Suppose, for instance, the ESQ-M is in POLY Mode and you set the Base Channel to 4. Any Track you select will now receive on Channel 4. Now you switch to MULTI Mode. Channel 4 is still the Base Channel. Track 0 will now receive on Channel 4 (since in MULTI Mode the Base Channel is associated with Track 0). Now you switch to MONO Mode. Channel 4 is still the Base Channel. Track 1 will now receive on Channel 4 (since in MONO Mode the Base Channel is associated with Track 1). And so on.

7. PROG — Current Program on the Track

This parameter shows, and lets you change, the number of the Program that is on the selected Track. Changing the Program here has exactly the same effect as changing the Program on the **Program** Page (with the Data Entry Slider or the Up and Down Arrow buttons). A Program change made here will be reflected on the Program Page, and vice versa.

The Display shows the current Track (indicated as **T0, T1, T2**, etc.) and the Program number assigned to that Track (indicated as **PROG=**). It is the same three-digit Program Number that appears on the Program Page. As is the case on the Program Page, you can select Program Numbers 001 through 040 when no Cartridge is inserted, and Numbers 001 through 120 when a Cartridge is inserted.

This parameter is useful when you are setting up MIDI Channels, Programs and Mix levels for several Tracks. You can use this parameter to select a new Program for the current Track without having to exit the MIDI Page.

8. MIX — Track Mix Level

TRACK MIX determines the relative volume of each Track. You can think of this control as the "mixdown" section of the ESQ-M. The Display shows the current Track (indicated as **T0, T1, T2**, etc.) and the Mix Level assigned to that Track (indicated as **MIX=_**). The Mix Level is adjustable from OFF to 63. When set to OFF, the Track will not sound.

The mix for a particular Track can be set from the front panel with this control, or remotely by sending MIDI Volume (MIDI Controller #7) to a Track.. (Not all instruments send MIDI Volume, but each of the ESQ-M's Tracks will respond to it from those who do.)

Also, when the PEDAL Function switch on the MASTER Page is set to **PEDAL=VOL**, moving the Foot Pedal will change the Mix Level of the current Track, and you will see that change reflected here in real time.

Section 4 — Programming the ESQ-M

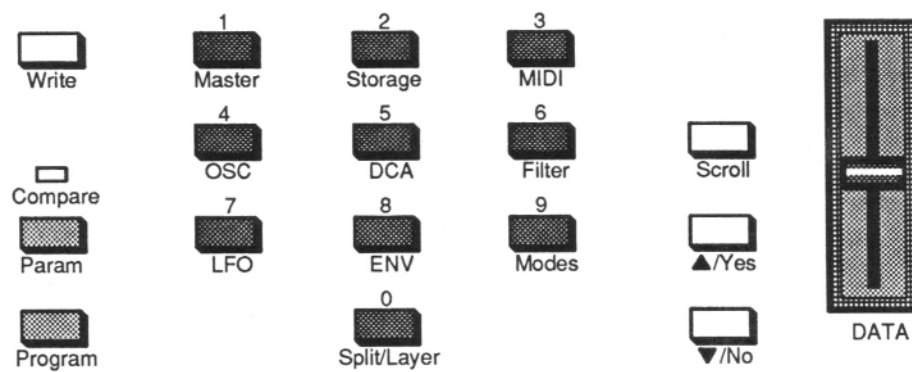

WAVEFORMS

DIGITAL WAVEFORM MEMORY

The same Digital technology that allowed the ENSONIQ Mirage to make Digital Sampling affordable gives the ESQ-M its ability to play complex sounds from "the real world". Rather than just producing simple sawtooth or square waves, the ESQ-M's three Digital Oscillators "read" from memory whichever Waveforms they are instructed to play.

The ESQ-M has 32 different **Waveforms** stored in its **Digital Waveform Memory**. Some of these Waveforms have been sampled (digitally recorded) from musical instruments; others have been created synthetically.

WHAT'S A WAVEFORM?

The Waveforms are the "raw material" of the sounds that the ESQ-M makes. A waveform is a single cycle of a sound wave. It is Digitized, or converted into a series of numbers, and stored in the ESQ-M's Digital Waveform Memory. When you play a note, each of the ESQ-M's three Oscillators "reads" the proper Waveform from the Memory, similar to the way a Compact Disc player reads the music on the disc when you play a CD.

By rapidly repeating this single cycle over and over, the Oscillator can produce a pitched sound which becomes a continuous Sound wave:

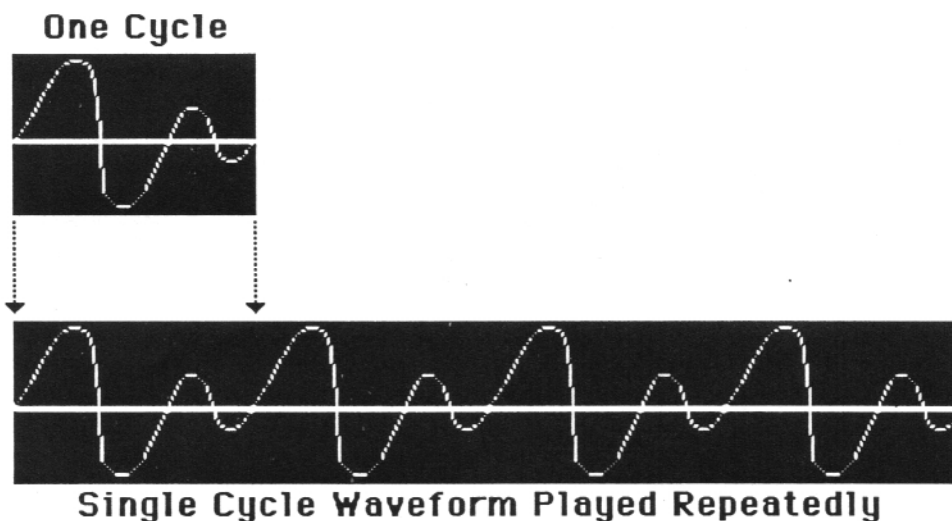

Unlike the sounds generated by analog oscillators, Digital Waveforms can be very complex, and can contain any combination of harmonics — frequencies that are multiples of the wave's fundamental frequency. Every Waveform has its own unique **Spectrum**, which is the number and amplitude of harmonics present in the Wave. It is this Spectrum which gives every sound its own identifiable characteristics.

SYNTHETIC WAVEFORMS

Most of the Waveforms in ESQ-M's Digital Waveform Memory have been generated synthetically, using a number of different techniques, to create a variety of Waves which contain specific harmonics in specific amounts. By assigning different combinations of these synthetic Waveforms to the three Oscillators, it is possible to create sounds with almost any timbral characteristics.

SAMPLED AND MULTI-SAMPLED WAVEFORMS

Other Waveforms are sampled — a single cycle of a sound wave from some real musical source has been isolated and stored in Memory. By playing back these Waveforms in the manner described above, it is possible to synthesize sounds that capture the character of the Source instrument in a way that no ordinary synthesizer can.

Some of the ESQ-M's Waveforms (such as the Piano Waveform) have been **Multisampled** — that is, different waves play in different ranges of the instrument. This is because many sounds lose their realism if they are transposed too far from their source. The lowest note on a piano, if transposed up three octaves, doesn't sound like a piano any more. Neither does the highest note transposed down three octaves. Or to use another example — take a recording of a human voice and play it back twice as fast. Does it sound like a human voice? No. What does it sound like? Chipmunks.

Multisampling means that the low notes of the Piano Waveform were sampled from a low note on the piano, the middle notes were sampled from a middle note, and so on. So really you get more than 32 Waveforms, since some of them are actually made up of several Waveforms. You don't have to do anything special to use these Multisampled Waveforms. The ESQ-M treats each one as a single Waveform, and they are selected just like the others.

The Synthetic Waveforms can be combined with the Sampled ones, to add harmonic content which enhances the sound in some way. Any combination of Waveforms is possible, and each will have its own unique sound.

NAMES

The **ESQ-M's** 32 Waveforms are identified by their **Names**. In the case of the Sampled Waveforms especially, you should neither take them too literally, nor let yourself be limited by those Names. Don't, for example, expect the VOICE Waveform to always sound like Vocals — everything depends on the Program (the Envelopes, the Filter settings, etc.). On the other hand, don't let the Names alone limit what you try in terms of being creative. For example, if you find that within a certain Program the **BASS** Waveform sounds like a harpsichord, or a kazoo, or whatever, go with it. Your ears are the only valid judge of what works.

SELECTING A WAVEFORM

Each of the three Oscillators can play a different Waveform within a Program. The Waveforms are selected from the **Oscillator Pitch Pages** [**OSC1**, **OSC2** and **OSC3**]. The Waveform parameter is selected like any other parameter on the ESQ-M.

To select a Waveform for **Oscillator 1**:

1. Press the **Param** button to put the ESQ-M into Parameter mode.
2. Press the **OSC** button on the Control Keypad, then within 2 seconds (while the question mark is flashing) immediately press 1, to select **Oscillator 1's** Page.
3. Press Scroll until the Display reads "WAVE=_____"

Now you can use the Data Entry Slider and the Up and Down Arrow buttons to change the Waveform that **OSC1** will play. There are 32 available choices, each with its own Name. Follow the same procedure to select a Waveform for **OSC2** and **OSC3**. Later in this section each Waveform is detailed by Name.

CHECK THEM OUT

The best way to understand the Waveforms is not to read about them, but to hear them. Select the Program called BASIC (it's Program # 112 in the ENSONIQ Voice-80 Cartridge, Volume 1). This Program has only one Oscillator playing, and all the Envelopes wide open. Select the **OSC1** Page as shown above, and Scroll to the WAVE parameter. The Sawtooth Wave is selected (WAVE= SAW).

While repeatedly playing a note or chord on your master keyboard, press the **Up Arrow/Yes** button to step to the next Waveform. Press it again to hear the next one, and so on. In this way you can listen to each Waveform in succession, compare them to each other, and compare the timbral characteristics you hear in various ones to their text descriptions below. When you are looking for the right Waveform for a particular application, let your ears be the guide.

THE WAVEFORMS

1) CLASSIC SYNTH WAVEFORMS

These Waveforms collectively form the bases of almost all classic Analog synthesizer sounds. Their inclusion here gives the **ESQ-M** its ability to make those sounds with the best of them.

SAW — SAWTOOTH. The Sawtooth Wave needs no introduction. It contains all the harmonics, and is extremely bright. The Sawtooth is the basis for many Analog sounds, notably Strings and Brass.

BELL. The Bell Waveform contains many widely spaced harmonics, many of them odd harmonics. It makes bright, Bell sounds.

SINE. The Sine Wave contains only the Fundamental, with no higher harmonics. It has very pure tone, good for flutes, organs, etc.

SQUARE. The Square Wave contains the Fundamental and all its odd-numbered harmonics at a fixed ratio. The level of the harmonics is the same as the Sawtooth, except that there are no even-numbered harmonics. The Square Wave has a hollow sound, and is also the basis for many classic synth sounds.

PULSE. This Pulse Wave contains the Fundamental and all its integral harmonics at equal amplitude. This is a very bright Waveform.

NOISE 1. This is a Waveform taken from filtered Noise. It works best when tuned down low (**OCT= -3**). (Note that the Noise Waveforms here differ from analog Noise generators, in that Waveforms are by definition repeating patterns, and Noise is random.)

NOISE 2. This is very close to White Noise. It has almost no pitch, but modulating the Oscillator playing this Waveform with a fast LFO or an Envelope, will eliminate what pitch tracking there is.

NOISE 3. This Waveform is good for putting random frequency components into a sound (the attack "ping" of a mallet instrument, for example). It has a clangorous, metallic quality, and its pitch tends to be unpredictable.

2) SAMPLED WAVEFORMS

The **Sampled Waveforms** contain harmonics that simply cannot be generated by an ordinary synthesizer, since every musical source produces its own unique waveshapes and Frequency Spectrum.

BASS. This is a bright Bass Waveform, full of interesting harmonics, which, depending on the Program, makes a great regular or synth-type Bass. Higher up it takes on a Clay-like character,

PIANO. A multisampled acoustic Piano wave.

EL PNO — ELECTRIC PIANO. A Waveform taken from a popular Electric Piano — allows you to recreate this instrument with tremendous realism.

VOICE 1. A multisampled Vocal wave, saying "Ah".

VOICE 2. A multisampled Vocal wave, using the same waveforms as **VOICE 1**, but with a higher split point for each Wave

KICK. This Waveform is optimized for one application. Tuned to **OCT= -3**, properly enveloped, and played on the lowest key of the Keyboard, it reproduces a Kick drum.

----> **REED.** One cycle from an Alto saxophone wave. With different Programs it can sound like different Reed Instruments.

----> **ORGAN.** This Waveform contains the fundamental and four Octaves (2nd, 4th, 8th, 16th and 32nd harmonics). Instant Pipe Organ. Also good for Bells.

3) **ADDITIVE SYNTHESIS WAVEFORMS**

These three Waveforms were created through Digital Additive Synthesis. Each contains the Fundamental and certain specific harmonics in equal amounts.

SYNTH 1. Contains the fundamental, and every third harmonic-, starting from the 2nd, up to the 26th , in equal amounts:

Harmonics: 1, 2, 5, 8, 11, 14, 17, 20, 23, 26.

SYNTH 2. Contains the fundamental, and every third harmonic, starting from the 4th, up to the 25th , in equal amounts:

Harmonics: 1, 4, 7, 10, 13, 16, 19, 22, 25.

SYNTH 3. Contains the fundamental, and the prime-numbered harmonics, up to the 23rd, in equal amounts:

Harmonics: 1, 2, 3, 5, 7, 11, 13, 17, 19, 23.

4) **FORMANTS**

These five Waveforms were created through a process called Time-Domain Formant-Wave-Function Synthesis. Each one has a sharp peak in its frequency spectrum - like pushing one band of a graphic equalizer all the way up. These Waves are multisampled in such a way that the frequency peak remains relatively constant up and down the keyboard, rather than tracking the pitch of the note. Each has its peak centered around a different frequency. They tend to have a nasal quality, and make excellent component waveforms for Vocals, Strings etc.

FORMT 1. Has a frequency peak centered around 750 hz. **FORMT 2.**

Has a frequency peak centered around 1 khz. **FORMT 3.** Has a

frequency peak centered around 1.4 khz. **FORMT 4.** Has a frequency

peak centered around 1.75 khz. **FORMT 5.** Has a frequency peak

centered around 2.25 khz.

5) **BAND LIMITED WAVEFORMS**

These Waveforms are Band Limited - that is, their harmonic content has been restricted along certain specific lines. They are good for adding controlled harmonics to a sound, or for combining to achieve various timbres. Some are other Waves with some harmonics pulled out; some were built "from scratch" to contain only certain harmonics.

PULSE2. Originally a Pulse Wave, like the Pulse Wave above, but with only the first 11 harmonics left in.

SQR 2. Originally a Square Wave, but with only the first 7 harmonics left in.

4 OCTS. Contains, in equal amounts, only four harmonics - 1st, 2nd, 4th, 8th. Fundamental and three Octaves; again, good for Organ sounds.

PRIME. Contains, in equal amounts, only the first five prime-numbered harmonics: 1st, 3rd, 5th, 7th, and 11th.

BASS 2. Originally the Bass Wave, but with only the first eighteen harmonics left in.

E PNO2. Originally an Electric Piano Wave, but with only the first nine harmonics left in. An Electric Piano without the "ping."

OCTAVE. Contains only the 1st and 2nd harmonics in equal amounts — the Fundamental and one Octave.

OCT+5. Contains only the 1st, 2nd, and 3rd harmonics in equal amounts — the Fundamental, one Octave and the Fifth above the octave.

MODULATORS

ABOUT MODULATION

To **modulate** something is simply to cause it to change. Within the Voice architecture of the ESQ-M we begin by setting basic, or Manual, levels for Volume, Pitch, Brightness, etc., and we then **modulate** those levels in various ways in order to create movement and dynamics within the Sound.

Suppose you switch on your stereo, and turn the volume half way up. We can call this the Manual Volume setting. It will stay at that level until it's changed. Now suppose that you take the Volume knob and begin quickly turning it up and down, so the volume gets continuously louder and softer, louder and softer. What you would be doing is **modulating the volume** of your stereo. If you were to take the Treble control, and do the same to that knob, you would be **modulating the brightness** of your stereo.

In much the same way we modulate various levels within the ESQ-M (though generally the approach is less haphazard). There are 15 different **Modulation Sources** available, and they can each be independently assigned to vary the Manual levels for:

- > The Pitch of each Oscillator [**OSC 1, OSC 2** and **OSC 3**]
- > The Volume of each Oscillator [**DCA 1, DCA 2** and **DCA 3**]
- > The **Filter Cutoff Frequency**, or the Brightness of the Program [FILTER]
- > The Depth of the **Low Frequency Oscillators** [**LFO 1, LFO 2** and **LFO 3**] and ----> Panning the Program within the stereo mix [DCA 4] Page

The Final Volume of the Program [DCA 4] is a special case — it is always controlled by **Envelope 4 (ENV 4)**, which is fixed as its Modulator.

SELECTING A MODULATOR

On each of the **Oscillator Pitch** Pages, [**OSC 1, OSC 2** and **OSC 3**], the **Oscillator Volume** Pages, [**DCA 1, DCA 2** and **DCA 3**], and the FILTER Page, you can select two different Modulators. The format is similar for all these Pages — the effect of any modulators you select will be added to (or subtracted from) the Manual Levels that are set elsewhere on the Page.

Take for example the **OSC 1** Page. To select a Modulator (or Modulators) for the pitch of **Oscillator 1**, first select the **OSC 1** Page. Now Scroll to the parameter **MOD 1**:

<p>OSC 1 MOD 1</p> <p>LFO 1</p>

Use the Data Entry Slider and the Up and Down Arrow Buttons to select from among the 15 available Modulation Sources. Follow the same procedure to select Modulators on the other Pages listed above.

For modulating Program **Pan** (**PNMOD** on the **DCA 4** Page) and LFO depth [**LFO 1, LFO 2** and **LFO 3** Pages] only one Modulator can be selected.

Helpful Hint:: Moving the Data Entry Slider all the way up selects *OFF*, which is handy if you don't want a Modulator applied in a particular location.

MODULATION DEPTH

Once you have selected a Modulator, [MOD1] for instance), Scroll to the next parameter [MODAMT1] and use this control to adjust the **Modulation Amount** (also referred to as Modulation Depth). The Modulation Amount is the amount by which the Modulator will affect the Manual Level.

Once the [MODAMT1] is selected, use the Data Entry Slider and the Up and Down Arrow Buttons to adjust the Modulation Depth. Modulation Depth can be Positive or Negative. A Modulation Depth of **+00** has the same effect as turning the Modulator *OFF*.

To select a second Modulator (on those Pages where two are available) simply Scroll to the parameter [MOD2], and select a Modulator from among the 15 available sources. Then Scroll to the next parameter [MODAMT2], and use the Data Entry Slider and the Up and Down Arrow buttons to set the Modulation depth or amount.

Helpful Hint: With Modulation Depth, as with all Parameter values that have a center value (in this case, **+00**), there is an easy way to reach that value. With the Modulation Depth selected, press the **Down Arrow** Button, and while holding it down, press the **Up Arrow** Button. This automatically sets the Modulation Depth to **+00**. This technique can be used to quickly "center out" almost any parameter, such as Master Tuning, Envelope Levels, etc.

MODULATION SOURCES

The 15 **Modulation Sources** available on the ESQ-M are as follows:

----> **LFO 1, LFO 2 and LFO 3**

The three **Low Frequency Oscillators** generate only very low frequency waves, which can produce Vibrato, Tremolo, and many other effects, depending on the LFO wave selected, and where it is applied as a Modulator. There are four possible waveshapes for each LFO. The Square wave only goes in a positive direction; the Triangle, Sawtooth and Noise Waves go positive and negative. (Though negative Modulation depth will reverse the effect.) The Diagrams below show the maximum levels for each LFO waveshape.

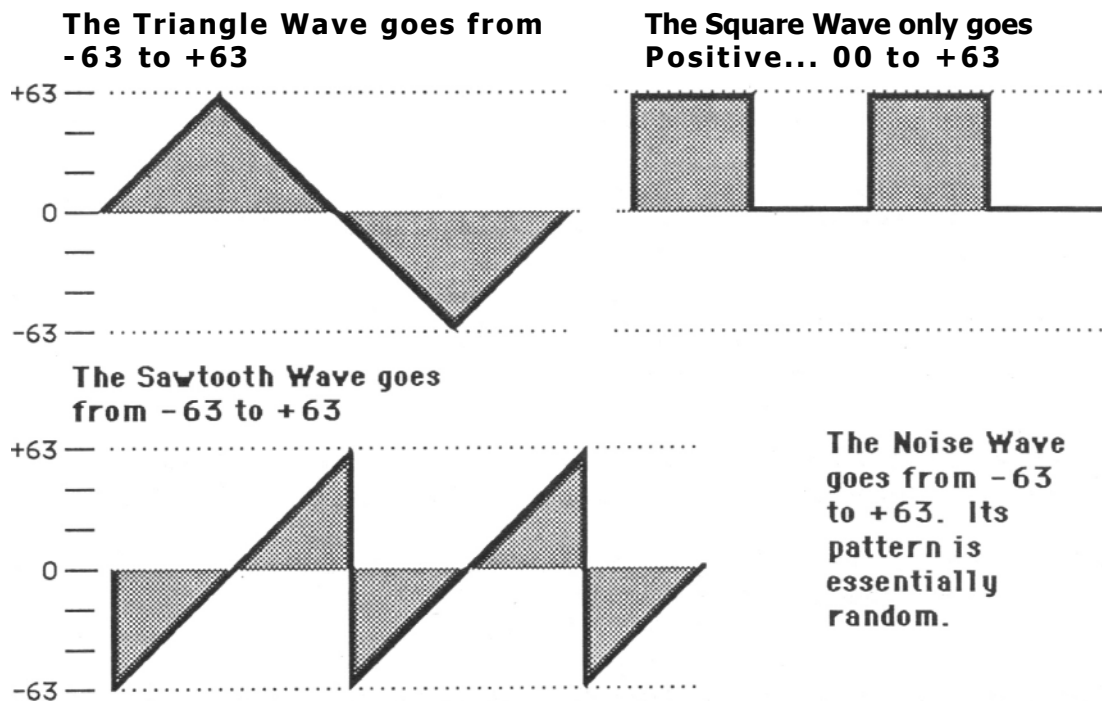

See the LFO Page (p. 64) for a more complete discussion of the LFO's.

ENV 1, ENV 2, ENV 3 and ENV 4

The ESQ-M has four complex **Envelopes** which can be applied as Modulators. Any of these four Envelopes can be routed to anywhere a Modulator can be selected. Note that ENV 4 always modulates DCA 4 (the Final Volume of the Program). However, ENV 4 can be routed elsewhere to modulate other things in addition to DCA 4. Envelope Levels can be positive or negative.

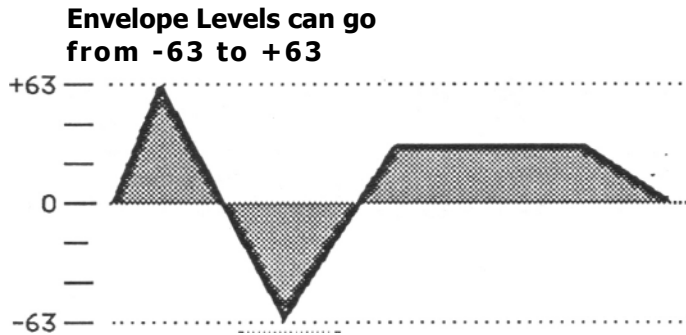

A comprehensive discussion of the ESQ-M Envelopes follows in the Section entitled **Understanding the Envelopes**, p. 66.

----> **VEL — Velocity**

Velocity means how hard you strike a key. Selecting VEL as a Modulator allows you to modulate any Manual Level with Velocity. Velocity as a Modulation Source only goes positive (though assigning a negative Modulation depth will make the net result be to decrease a Manual Level with Velocity). VEL is velocity with a straight linear curve. Note that if you drive the ESQ-M from a controller which does not send key velocity, this parameter will have no effect.

----> **VEL 2**

This is Velocity with a different Curve. Where the effect of VEL is linear, VEL 2 reaches the top end of the Modulation range quicker, with less velocity, and after that the curve levels off. (Again, if you drive the ESQ-M from a controller which does not send key velocity, this parameter will have no effect.) The illustration below shows the difference between VEL and VEL 2.

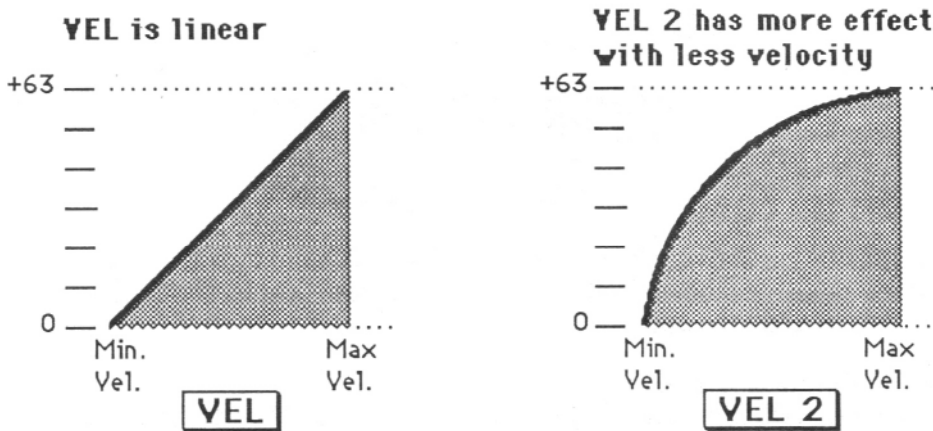

----> **KYBD — Keyboard Tracking**

Uses the position of a note on the Keyboard as a Modulator. The scaling effect of this Modulator is figured from MIDI key 0 to MIDI key 127.

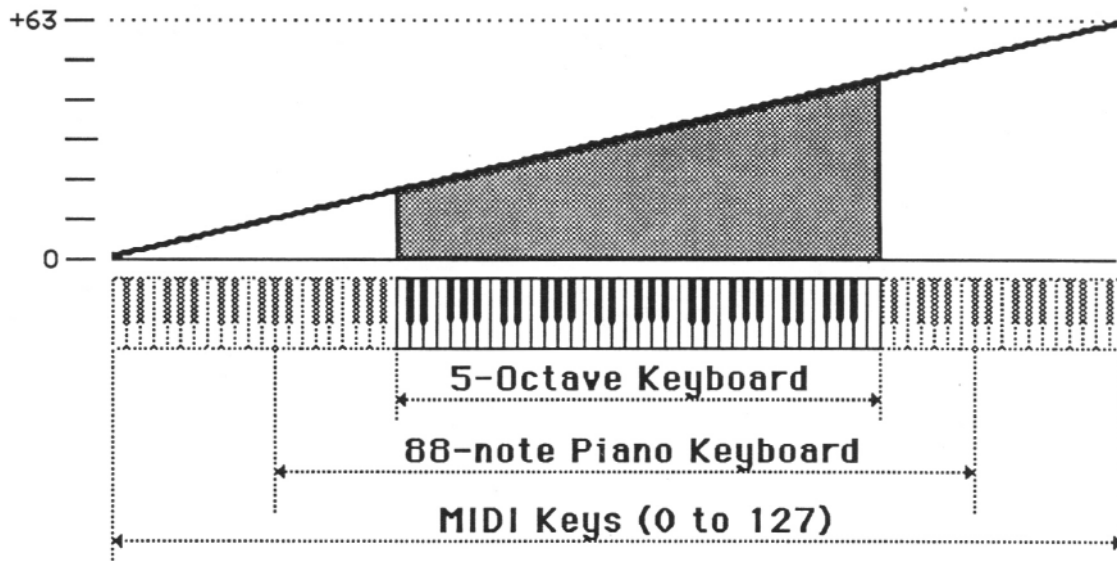

As the above illustration shows, the effect of **KYBD** is only positive-going (though a negative Modulation depth will reverse the effect). Since scaling starts from MIDI key 0, there will always be some effect on any keyboard, even on the lowest note. Manual Levels should be adjusted accordingly.

KYBD 2

Another way to modulate any Manual Level with the position of a note on the Keyboard, **KYBD 2** employs a different curve. **KYBD 2** goes negative as well as positive and, unlike **KYBD**, has its full effect over the range of a 5-octave keyboard, such as that of the ESQ-1.

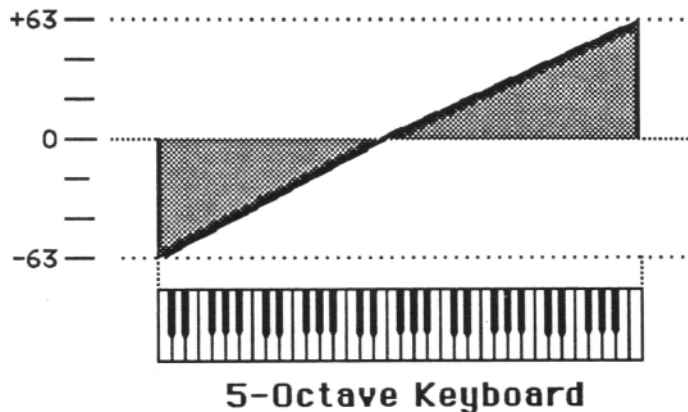

As the above illustration shows, the effect of **KYBD 2** is to reduce the Manual Level on notes below the break point (E above Middle C), and increase levels above that point. Negative Modulation depths will do the opposite.

WHEEL — Modulation Wheel

The MOD Wheel (MIDI Controller #1) is assignable wherever a Modulator is selected. To use the MOD Wheel for Vibrato (one common application) **WHEEL** must be assigned to modulate the LFO that is modulating Oscillator Pitch. The effect of **WHEEL** as a modulator is positive-going only, from 0 (Wheel towards you) to +63 (Wheel away from you). Negative Modulation depths will reverse the effect.

PEDAL — Voltage Control Foot Pedal

This selects the Foot Pedal, with which many synthesizers are equipped, as a Modulator. (It will also respond to the optional SW-10 Foot Pedal, which can be plugged directly into the PEDAL/CV Jack on the ESQ-M's rear panel) Its effect will be the same as that of the MOD Wheel. The Pedal makes an excellent alternative to the MOD Wheel when you wish to apply Modulation and both hands are full. It can be applied wherever a Modulator is selected.

Note that the PEDAL Function Select parameter on the MASTER Page must be set to **PEDAL=MOD**, or an SW-10 Foot Pedal plugged into the **ESQ-M's PEDAL/CV** Jack will not work as a modulator. When the Pedal Function Select parameter is set to PEDAL=VOL, the Pedal becomes a Volume Pedal.

Foot Pedal (*not* the Volume Pedal — that's a separate controller) is MIDI Controller #4. Note that if you drive the ESQ-M from a keyboard equipped with a Foot Pedal, and wish to use the Pedal as a Modulator in your ESQ-M Programs, you should select this modulator, *not* XCTRL (see below).

XCTRL — External Controller

Any MIDI Controller — such as a Breath Controller, Data Entry Slider, etc. — which is received via MIDI from the master synth or sequencer can be assigned as a Modulator within your ESQ-M Programs. On the MIDI Page, you select the number of the External Controller that will be received by the ESQ-M (only one can be selected at a time).

For example, if you have a Keyboard with a Breath Controller:

1. Make sure both instruments have Controllers Enabled (MIDI Page);
2. Select Breath Controller as the External Controller that will be received by the ESQ-M (XCONTRL=02, also on the MIDI Page);
3. Assign XCTRL as a Modulator for Oscillator Volume, Filter Cutoff Frequency, or some other Manual level within a Program, as shown in the following Section. Now when you play, blowing into the Breath Controller will affect whatever Level(s) you assigned XCTRL to modulate.

PRESS — Pressure (After-touch)

Pressure, also called After-touch, is recognized by the ESQ-M, and can be Programmed as a modulator anywhere a modulator is selected. A Control on the MIDI Page enables Pressure to be received, as well as determining which type will be received — Key or **Channel** Pressure. (See MIDI Page, p. 33.)

If you will be driving the ESQ-M from a synth which sends Pressure, you can assign Pressure as a Modulator within your ESQ-M Programs, just as you would the MOD Wheel, or the CV Pedal. Just remember that for it to be received by the ESQ-M, the correct type of Pressure must be enabled on the MIDI Page.

USING MODULATORS

Following are some examples of ways in which modulators are used within the voice architecture of the **ESQ-M**.

Modulating Oscillator Volume

The Volume of each of the three Oscillators within a Program depends on a combination of two things:

1. the setting of the base, or Manual Level (the parameter "**LEVEL=_**" on the **DCA1**, **DCA2** and **DCA3** Pages), and
2. the effect of any **Modulators** applied on any of those Pages.

The Manual Level can be thought of as a **Volume Floor** :

----> If this Level is set to some value greater than Zero for a given DCA, and no Modulators are applied, The Oscillator will play at that level as long as a key is held down.

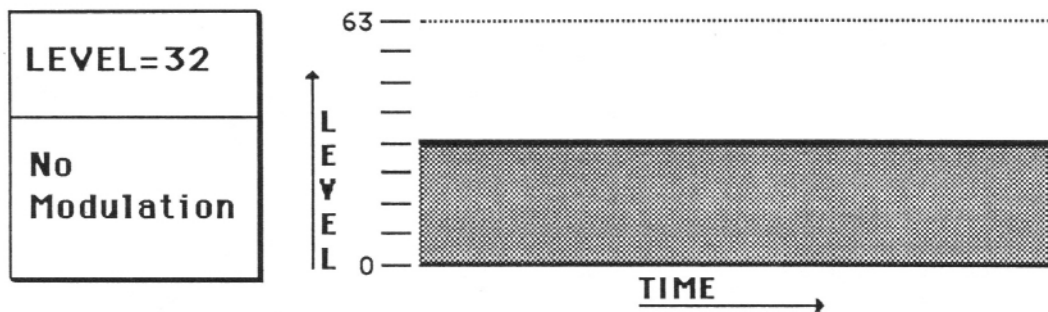

If the Manual Level is set to some value greater than Zero, and a Modulator (in this case an Envelope) is selected and assigned a depth other than Zero, the effect of the Modulator will be added to (or subtracted from) the Manual Level.

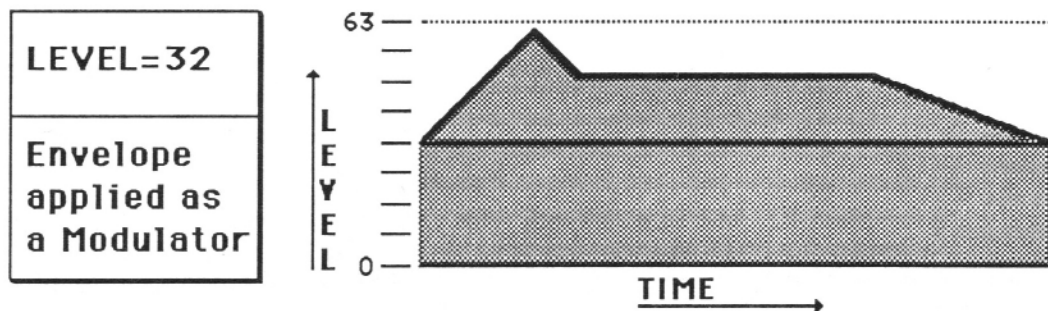

----> If the Manual Level is set to Zero, and a Modulator (the same Envelope) is selected and assigned a depth other than Zero, the depth of the Modulator alone will determine the Volume of the Oscillator.

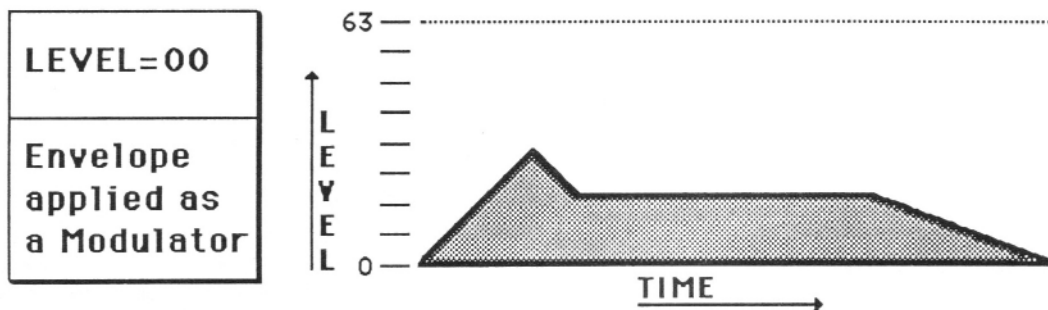

Bear in mind that when you use an **Envelope** or an **LFO (Low Frequency Oscillator)** as a Modulator, the final effect will depend on the Modulation Depth and the Levels that are set for the Envelope or LFO on their respective Pages.

Negative Modulation

Modulation Depth can be Positive or Negative (ranging from -63 to +63), making a great many interesting effects possible. If, for example, the Manual Level is set to **48**, and the same Envelope used in the previous examples is selected and assigned a Negative Modulation depth, the resulting Volume curve looks like this:

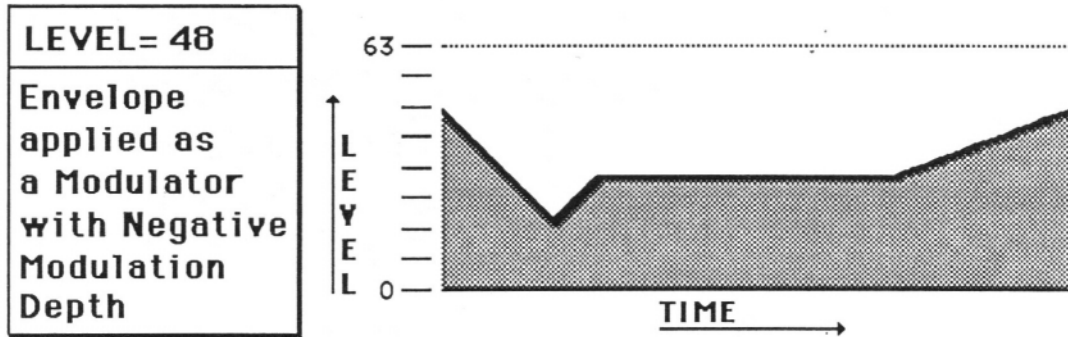

Modulating the Filter Cutoff Frequency

Like Oscillator Volume, the **Filter Cutoff Frequency**, or the Brightness contour of a Program, depends on a combination of two things:

1. the setting of the base, or Manual Level (the Control **FREQ.** on the FILTER Page), and
2. the effect of any **Modulators** applied on that Page.

----> If we set the **Filter Cutoff Frequency** manually (by adjusting the parameter FREQ on the FILTER Page) to a level of **64**, and turn all Modulators OFF, the Filter will open up to that level when a key is pressed, allowing frequencies below the Cutoff point to pass, and close down to Zero when the key is released.

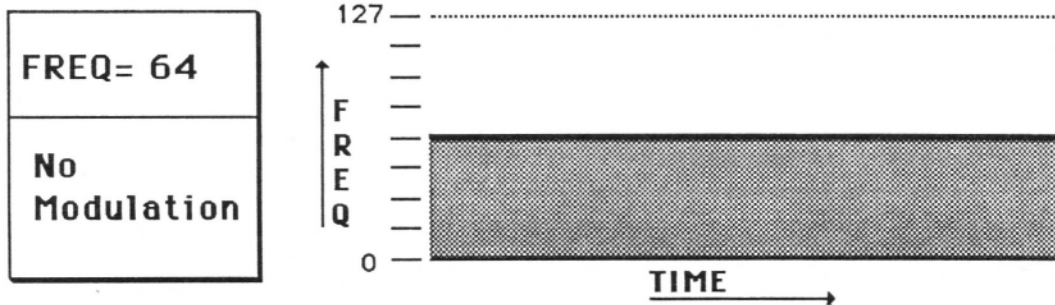

If we select an Envelope as a Modulator on the FILTER Page and assign it a value greater than Zero, its effect will be added to the the Manual Level.

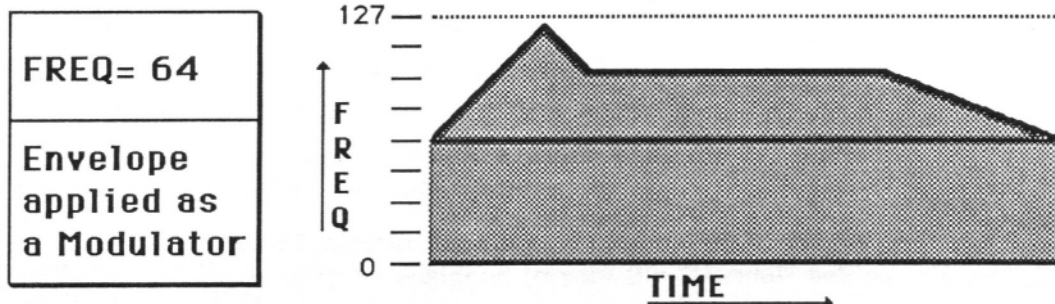

----> If, instead, we generate a Triangle-shape wave with one of the **LFOs (Low Frequency Oscillators)**, and apply that LFO wave as a Modulator on the **FILTER** Page, its effect will be added to the Manual Level, and the **Filter Cutoff Frequency** will rise and fall with the cycles of the LFO.

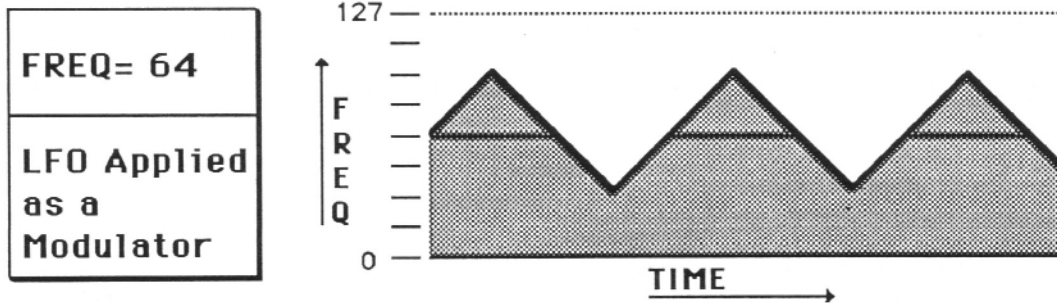

Of course, since two Modulators can be selected, you could apply both of these Modulators (or any other combination) to the **Filter Cutoff Frequency**, and their effect would be added together, and then added to the Manual Level.

As with Oscillator Volume, if the Manual Level on the **FILTER** Page is set to **FREQ. 00**, the **Filter Cutoff Frequency** will depend entirely on the depth and settings of any Modulators applied there.

Limits Of Modulation

For all Modulation effects there is a maximum and a minimum range that cannot be exceeded. For example, if the **Filter Cutoff Frequency** is manually set to its maximum value [127], you will not be able to modulate the Frequency any higher, with an Envelope, LFO or other Modulator.

You cannot modulate an Oscillator's Output Level lower than Zero (silence). If a Modulator doesn't seem to be having any effect, check that the other Modulators and manual settings are at appropriate levels.

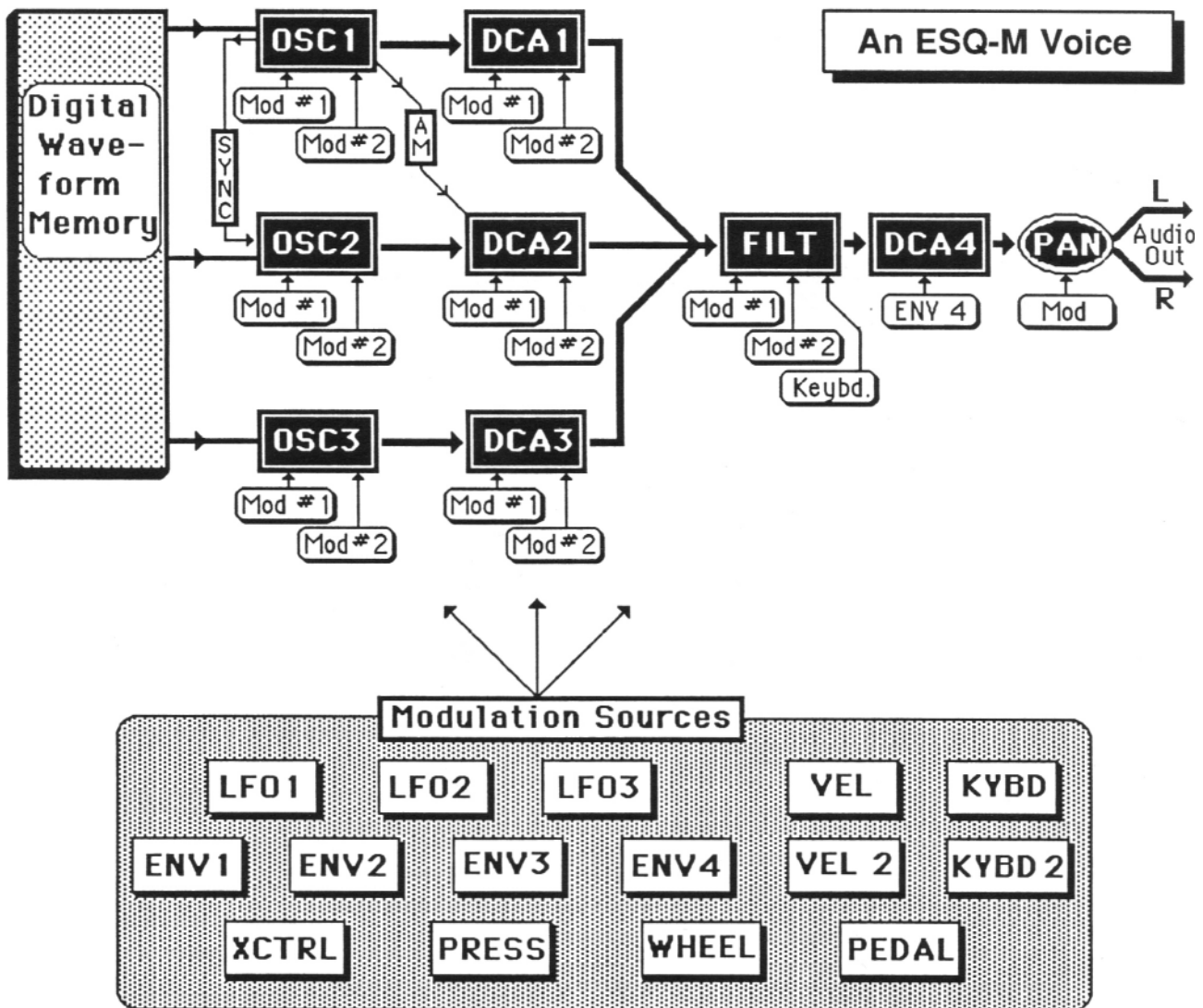

Any of these 15 Modulation Sources can be independently assigned wherever a MOD is indicated above.

For each of the ESQ-M's 8 voices:

- > Each Oscillator plays a Waveform from the Digital Waveform Memory;
- > The output of each Oscillator passes through the same-numbered DCA (Digitally Controlled Amplifier);
- > The output of the 3 DCA's passes through the Four-Pole Low Pass Filter;
- > The output of the Filter goes to the final DCA — DCA 4.
- > The output of DCA 4 goes to the Panner, which pans the Program between the Left and Right Audio Outputs.
- > Wherever a "Mod" is indicated in the above diagram, any of the 15 available Modulators may be assigned to vary the "Manual" setting.

page intentionally
left blank



PROGRAMMING PAGES

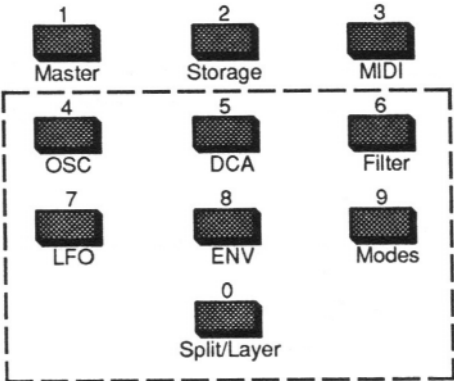

[OSC1] OSCILLATOR PITCH PAGE

[OSC2]

[OSC3]

Controls Oscillator pitch and selects the waveform to be played.

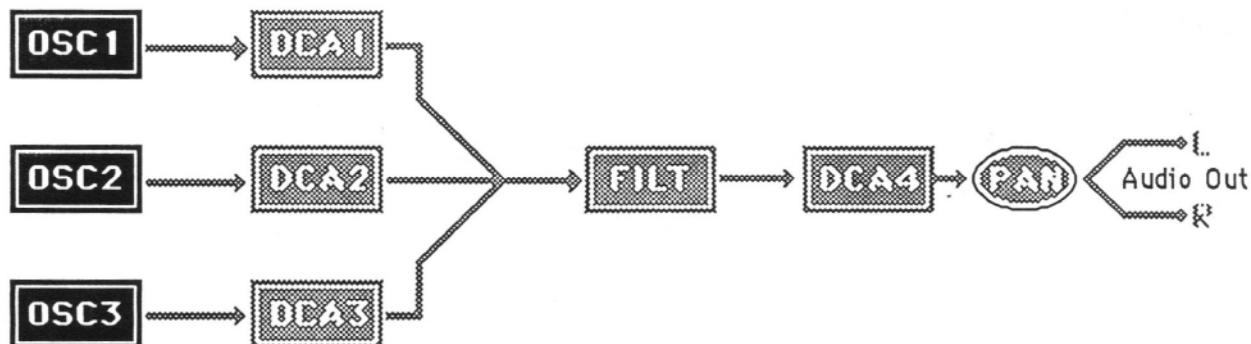

The format of the **Oscillator Pitch Page** is the same for [OSC 1], [OSC 2] and [OSC 3], although each of these Pages is entirely independent.

The Parameters on this Page can be selected by pressing Scroll until the desired parameter is showing *or* by entering the Parameter Number immediately selecting the Page.

Use these pages to:

- Adjust the pitch of each Oscillator by octave, semitone, and fine increments;
- Modulate the pitch of each Oscillator using any of the 15 available Modulation sources; and
- Select the Waveform to be played by each Oscillator.

~~OSC (1-3) PAGE~~

Parameters on this Page:

0	1	2	3	4	5	6	7
OCTAVE	SEMITONE	FINETUNE	WAVE	MOD 1	MODAMT 1	MOD 2	MODAMT 2

0. OCTAVE

Adjusts the pitch of the Oscillator by octaves.

Range: -3 To +3.

1. SEMITONE

Adjusts the pitch of the Oscillator up by semitones (halfstep). Adjusting this control upwards beyond 11 automatically increases the OCTAVE by one.

Range: 0 To 11.

2. FINETUNE

Adjusts the pitch of the Oscillator up by fine steps (detunes). Each step here is about 3 Cents (hundredths of a semitone).

Range: 0 To 31.

3. WAVE

Selects the **Waveform** that the Oscillator will play from among the 32 available Waveforms. (See WAVEFORMS, p. 40.)

4. MOD1 — Modulator #1

Selects the first source of Modulation. The Modulators selected on this page affect only the pitch of the Oscillator.

5. MODAMT1 — Modulator #1 Depth

Sets the depth, or amount, by which Modulator #1 will affect the pitch of the Oscillator. The Modulation amount can be positive or negative.

Range: -63 To + 63.

6. MOD2 — Modulator #2

Selects the second source of Modulation. The effects of Modulator #1 and Modulator #2 are added together. You can thus double the maximum Modulation depth of a given modulator by selecting the same source for Modulator #1 and Modulator #2. The Modulators selected on this page affect only the pitch of the Oscillator.

7. MODAMT2 — Modulator #2 Depth

Sets the depth, or amount, by which Modulator #2 will affect the pitch of the Oscillator. The Modulation amount can be positive or negative.

Range: -63 To + 63.

[DCA1] OSCILLATOR VOLUME PAGE

[DCA2]

[DCA3]

Controls The Volume of Oscillators 1 through 3.

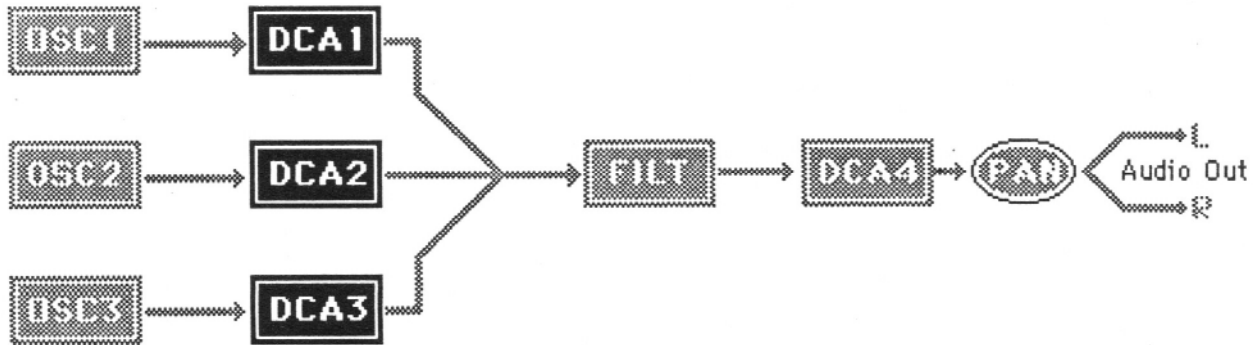

The format of the **Oscillator Volume Page** is the same for **DCA1**, **DCA2** and **DCA3**, although each of these Pages is entirely independent.

Each of these three DCA's (Digitally Controlled Amplifiers) controls the Volume (or amplitude) of the same-numbered Oscillator (OSC).

The Parameters on this Page can be selected by pressing Scroll until the desired parameter is showing *or* by entering the Parameter Number immediately selecting the Page.

Use these pages to:

- Set the Manual Output levels of the three Oscillators;
- Modulate those levels using any of the 15 available Modulation Sources; and
- Turn each Oscillator ON or OFF.

DCA (1-3) PAGE Parameters on this Page:

0	1		3	4	5
LEVEL	OUTPUT	MOD 1	MODAMT 1	MOD 2	MODAMT 2

0. LEVEL

Determines the Manual, or base, volume (amplitude) of the Oscillator. This Level can be thought of as a 'Volume floor' -- the effect of any Modulator(s) is added to the Level set by this parameter. So even if **LEVEL = 0**, the Oscillator will still have some amplitude if there is a Modulator (an **Envelope** for instance,) selected and assigned a Depth greater than Zero. Negative modulation depths bring the volume lower than the **LEVEL** setting. Large amounts of negative Modulation can silence the Oscillator, regardless of the setting of this control.

DCA's 1, 2, and 3 have been set up so that it is possible to get full volume from just one Oscillator. This means, however, that it is possible to clip (overload) the output stage when all three Oscillators are at full level. Different Waveforms contain different amounts of fundamental energy, so the effect will vary. a conservative rule of thumb for Oscillator Volume is as follows:

- With 1 Oscillator playing** -- set that Oscillator to **63**.
 - With 2 Oscillators playing** -- set both Oscillators to **56**.
 - With 3 Oscillators playing** -- set all three Oscillators to **52**.
-

1. OUTPUT — Oscillator Mute

Turns the Output of the Oscillator ON or OFF. This control is very helpful when setting up complex Programs, as it allows you to silence any Oscillator, and listen to the others, without disturbing your settings.

2. MOD1 — Modulator #1

Selects the first source of modulation. The modulators selected on this page affect only the amplitude of the Oscillator.

3. MODAMT1 — Modulator #1 Depth

Sets the depth, or amount, by which Modulator #1 will affect the amplitude of the Oscillator. The Modulation amount can be positive or negative.

Range: **-63 To +63.**

4. MOD2 — Modulator #2

Selects the second source of modulation. Again, a Modulator's maximum depth can be doubled, by assigning the same Modulator to **MOD #1** and **MOD #2**. The Modulators selected on this page affect only the amplitude of the Oscillator.

5. MODAMT2 — Modulator #2 Depth

Sets the depth, or amount, by which Modulator #2 will affect the amplitude of the Oscillator. The Modulation amount can be positive or negative.

Range: **-63 To +63.**

[DCA 4] FINAL VOLUME PAGE

Controls Program Volume and Panning.

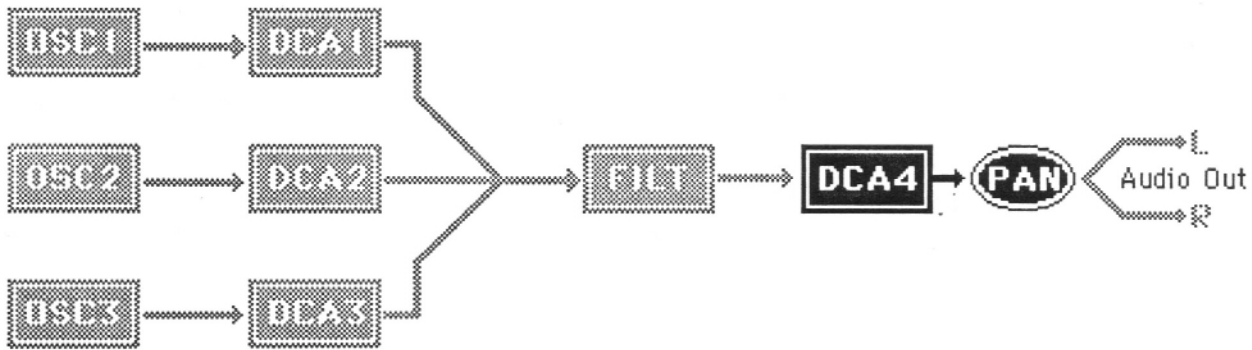

Note: The Modulation Source for [DCA 4] is always [ENV 4].

The outputs of the three Oscillators, after passing through the Filter, go to [DCA4]. This Final DCA (Digitally Controlled Amplifier), together with [ENV4], which is fixed as its Modulator, determines the overall volume envelope of the Program.

The Parameters on this Page can be selected by pressing Scroll until the desired parameter is showing *or* by entering the Parameter Number immediately selecting the Page.

Use this page to:

- Adjust the amplitude of the entire Program;
- **Pan** the Program left, right or center; and
- Modulate the Program **Pan** using any of the 15 available Modulation Sources.

DCA 4	PAGE	[Parameters on this Page:	
0	1	2	3
ENV4MOD	PANLOC	PaNMOD	PanMODAMT

0. ENV 4 MOD — Final Volume

Determines the amount by which **DCA 4** will be Modulated by ENV 4, which is fixed as its Modulator. The net effect of this parameter is to increase or decrease the Volume of the entire Program. This is useful for matching the levels of different Programs, to avoid radical volume changes when switching between them. Also it is useful for balancing the relative levels of Split and/or Layered Programs (see **SPLIT/LAYER** Page, p. 77).

Range: **00** to **63**.

Bear in mind that the overall Volume of the Program will depend on the setting of this parameter and the settings on the ENV 4 Page.

1. PANLOC — Pan Location, Manual Level

Pans the Program the between the Left and Right Outputs. Possible Values range from **00** (all the way to the Left), to 15 (all the way Right). A value of **08** will pan the Program to Center. Note that the **ESQ-M's** audio outputs must be connected in Stereo for this parameter to have any effect.

Range: **00** to **15**.

2. PNMOD — Pan Modulator

This control selects a Modulator for the PAN Setting. Modulators applied here will add to, or subtract from, the Manual Level, just as they do elsewhere. Thus an LFO used as a Modulator here will make the Program Pan back and forth with Time. Applying **Velocity [VEL]** here would make a note's placement in the stereo mix depend on how hard you strike a key. And so on.

Or you can apply the Keyboard (KYBD 2) as a Modulator to make the low keys play on the left side, the middle keys in the middle, and the high keys on the right side of the stereo mix. (See the Internal Factory Sound PIANO1 for an example of this effect.)

3. PMODAMT — Pan Modulator Amount (or Depth)

Sets the amount by which the **PAN Modulator** will affect the Manual Pan Setting. Higher values will cause more dramatic Pan Modulation. Negative Modulation Depths are particularly useful here. Any Negative value here (-32 for instance) will have exactly the opposite effect of the same, Positive, value (+32) in terms of how it affects the Pan of the Program (assuming a Manual Level of **08**).

Range: -63 to +63.

[FILT] FILTER PAGE

Controls the Four-Pole Low Pass Filter

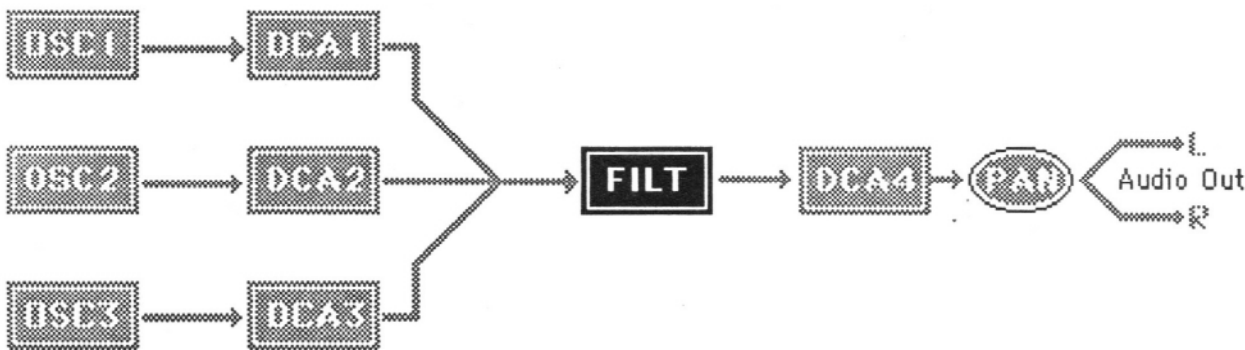

The outputs of the three Oscillators pass through the **Filter** before going to the Final Volume stage, [DCA4]. **The Filter** settings determine what frequencies will be allowed pass through to the output.

A **Low Pass Filter** allows only those frequencies below the **Filter Cutoff Frequency** to pass. Higher frequencies are filtered out. The Filter Cutoff Frequency is set to a certain level, and then it can be continually varied by modulating the Filter (with an Envelope, an **LFO**, **Velocity**, etc.).

The Parameters on this Page can be selected by pressing Scroll until the desired parameter is showing *or* by entering the Parameter Number immediately selecting the Page.

Use this page to:

- Set the Manual Level for the **Filter Cutoff Frequency**;
- Set the amount of Filter Resonance (or Q); and
- Modulate the **Filter Cutoff Frequency**, using the Keyboard "Control Voltage" and any of the 15 available Modulation Sources.

FILTER PAGE Parameters on this Page:

0	1		3	4	5	6
FREQ	RES (Q)	KBD TRAC	MOD 1	MODAMT 1	MOD 2	MODAMT 2

0. CT FREQ — Filter Cutoff Frequency

Sets the initial, or Manual Level of the **Filter Cutoff Frequency**. A higher setting will result in a brighter sound. This setting represents the "Filter Floor" -- the effect of any selected Modulators will be added to (or subtracted from) this level.

Range: 0 To 127.

1. RES (Q) — Filter Resonance

Sets the amount of **Filter Resonance**, or Q. This controls the amplitude of the resonant peak of the filter. When the Q is raised, the Filter Cutoff Frequency is emphasized over all other frequencies. By then modulating the Filter Cutoff Frequency with an Envelope, LFO, Mod Wheel etc., you can create Filter Sweeps, Wah and Growl effects.

Range: 0 To 31.

2. KBD TRAC — Keyboard Filter Tracking

This parameter sets the amount by which the location of a note on the keyboard will modulate the **Filter Cutoff Frequency**. (This is comparable to the **Keyboard Control Voltage** of most Analog synths.)

Higher values of this parameter will cause the Filter to open up more (get brighter) as you play higher up the keyboard. The maximum value (63) will raise the Filter Cutoff Frequency roughly one octave for each octave you go up the Keyboard.

Range: 0 To 63.

2. MOD1 — Modulator #1 Selects the first source of Modulation for the **Filter Cutoff Frequency**.**3. MODAMT1 — Modulator #1 Depth**

Sets the depth, or amount, by which Modulator #1 will affect the **Filter Cutoff Frequency**. Modulation amounts can be positive or negative.

Range: -63 To + 63.

4. MOD2 — Modulator #2 Selects the second source of Modulation for the **Filter Cutoff Frequency**.**5. MODAMT2 — Modulator #2 Depth**

Sets the depth, or amount, by which Modulator #2 will affect the **Filter Cutoff Frequency**. Modulation amounts can be positive or negative.

Range: -63 To + 63.

[LFO 1] LOW-FREQUENCY OSCILLATOR PAGE

[LFO 2]

[LFO 3]

Controls the three Low-Frequency Oscillators (LFO's)

The format of the **LFO Page** is the same for [LFO 1], [LFO 2], and [LFO 3], although each of these Pages is independent. The **Low Frequency Oscillators** are used as Modulators, and may be applied wherever a Modulation Source is to be selected.

Note that the **LFO Delay** (which normally allows the effect to enter gradually) is set using a **Ramp** which goes from **LEVEL 1** to LEVEL 2. Since **LEVEL 1** can have a higher value than LEVEL 2, the Ramp can actually be a decreasing one, causing the effect of the LFO to diminish, or disappear, over the time the key is held down.

The Parameters on this Page can be selected by pressing Scroll until the desired parameter is showing *or* by entering the Parameter Number immediately selecting the Page.

Use this page to:

- Set the LFO Frequency (speed);
- Determine whether the LFO resets each time a key is struck;
- Select the waveform that the LFO will play;
- Set **LFO Delay** parameters; and
- Select a Modulator from any of the 15 available Sources to modulate the Output Level of the **LFO**.

LFO (1-3) PAGE | Parameters on this Page:

0	1	2	3	4	5	6	7
FREQ	RESET	HUMAN	WAVE	LEVEL 1	DELAY	LEVEL 2	MOD

(PARAMETER PIC)

0. FREQ — LFO Frequency

Determines the speed of the LFO. Range: 0 To 63.

1. RESET

Turns RESET mode on or off.

When ON: The LFO Waveform will return to the beginning of its cycle each time a new key is struck. This is good for synchronizing LFO sweeps with key hits.

When OFF: The LFO wave will cycle continuously, without Resetting.

2. HUMAN — Humanize function

When ON: This control will add a random element to the **LFO Frequency**, making the effect less "mechanical sounding.

When OFF: The LFO Frequency will behave normally, with perfect repetition.

3. WAVE — LFO Waveform

Selects the **Waveform** which the LFO will play. The choices are:

TRI -- Triangle wave

SAW -- Rising Sawtooth wave (Use negative modulation for a falling Sawtooth.)

SQR -- Square wave (positive-going only)

NOISE -- Random

NOTE: Controls # 4, 5, and 6 combine to form a linear Ramp which defines the LFO Delay. The Ramp goes from **LEVEL 1, which is the starting Level, to **LEVEL 2**, which is the sustain Level, and it can be an increasing or a decreasing Ramp.**

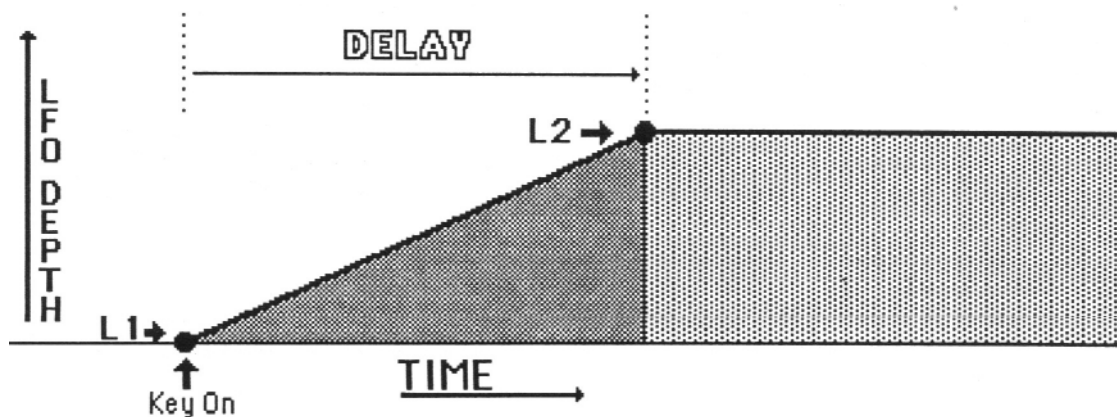

Example of LFO Modulation which "fades in" over Time.

4. LEVEL 1

This is **starting level**, the Level at which the LFO will play when the key is first struck.
Range: 0 To 63.

5. DELAY

Determines the **Rate** at which the LFO's amplitude will go from **LEVEL 1** to **LEVEL 2**.
Range: 0 To 63.

Note that here it is the Rate of Change (or the Slope of the Ramp) which is set, not a fixed Time. Therefore, lower values of this parameter will cause a **longer** Delay; **higher** values will result in a **shorter** Delay. The amount of Time it takes for the LFO to reach **LEVEL 2** thus depends on both the Rate and the Level.

A value of Zero will cause the LFO to remain at LEVEL 1.

6. LEVEL 2

This is **final level**, the Level that the LFO will reach at the end of the Ramp defined by the DELAY. It will remain at this Level until the key is released.

Range: 0 To 63.

7. MOD — LFO Depth Modulator

Selects the **Modulation Source** for LFO depth. The effect of this Modulator is added to the amount of LFO depth provided by the Ramp defined by Controls # 6., 7. and 8.

Note that the LFO itself can be used to modulate its own Output, or that of another LFO, producing unusual LFO waveforms.

The final, modulated, LFO Output is then available as a Modulation Source, whose depth can be adjusted precisely using the Modulation Depth controls on the other Pages.

Note: To use the MOD Wheel for Vibrato within a Program, perhaps the most common application for an LFO:

- 1) assign WHEEL as the Modulator for an LFO,
- 2) set L1 and DELAY to Zero for that LFO, and
- 3) assign that LFO to modulate the Pitch of the Oscillators (OSC Pages).

Within the Factory Sounds that came with your **ESQ-M**, **LFO 1** is always used for Wheel Vibrato (where it is applicable).

UNDERSTANDING THE ENVELOPES

An **Envelope** is a shape, or "contour" that we apply to some signal source to make it change through time. Naturally occurring sounds have their own Envelopes. They don't just start and stop — they might start loud and fade to silence, or slowly swell from silence to a huge crescendo; they might start out very bright and grow duller; they might have subtle variations in pitch, and so on.

In a synthesizer we imitate these effects, and create wholly new ones, by generating Envelopes and then using them to modulate pitch, volume, brightness, etc. The ESQ-M has four **Envelopes** which can be independently assigned as modulation sources to the various **OSC's**, **DCA's**, **LFO's**, **PAN** and the **FILTER**.

The ADSR Connection

Let's start by taking a look at the commonly used ADSR (Attack, Decay, Sustain, Release) type Envelopes found on many synthesizers. With the ADSR Envelope, the name says it all. You have four parameters to control:

Attack — The Time it takes to go from zero, when a key is struck, to peak level
Decay — The Time it takes to go from the peak level to the Sustain Level
Sustain — The Level at which the signal remains as long as the key is held down
Release — The Time it takes to return to zero after the key is released

ADSR Envelope

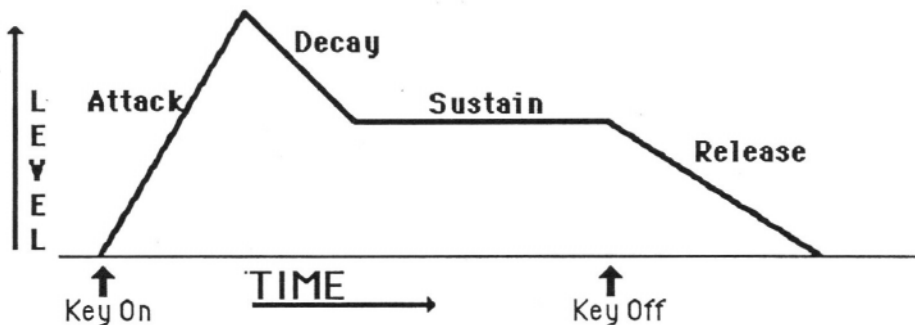

Notice that an Envelope is really just a series of Levels that change through Time. With the four parameters of the ADSR Envelope, we can control three Times (Attack, Decay and Release) and one Level (Sustain). This is fine for many basic volume and brightness Envelopes, but for more complex sounds — for subtle pitch Envelopes and other cool effects — it becomes necessary to have more specific control over more **Times** and **Levels**. Which brings us back to the **ESQ-M**.

Times and Levels

The four Envelopes on the ESQ-M are defined in terms of **Time** and **Level**. For each Envelope, you have control over four Time segments (**TIME 1**, **TIME 2**, **TIME 3**, and **TIME 4**) and three Levels (**LEVEL 1**, **LEVEL 2** and **LEVEL 3**).

When a key is struck, the Envelope level, starting at Zero, takes a fixed amount of time, defined by **TIME 1**, to reach **LEVEL 1**. It then takes **TIME 2** to reach **LEVEL 2**. Next, at the end of **TIME 3** it reaches **LEVEL 3**, where it will remain as long as the key is held down. After the key is released the signal takes **TIME 4** to return to Zero.

The three Level parameters appear on each **Envelope Page** as [**LEVEL 1**], [**LEVEL 2**] and [**LEVEL 3**]; the four TIME parameters as [**TIME 1**], [**TIME 2**], [**TIME 3**] and [**TIME 4**]. The figure on the next page shows a typical Envelope as defined by the ESQ-M Envelope parameters:

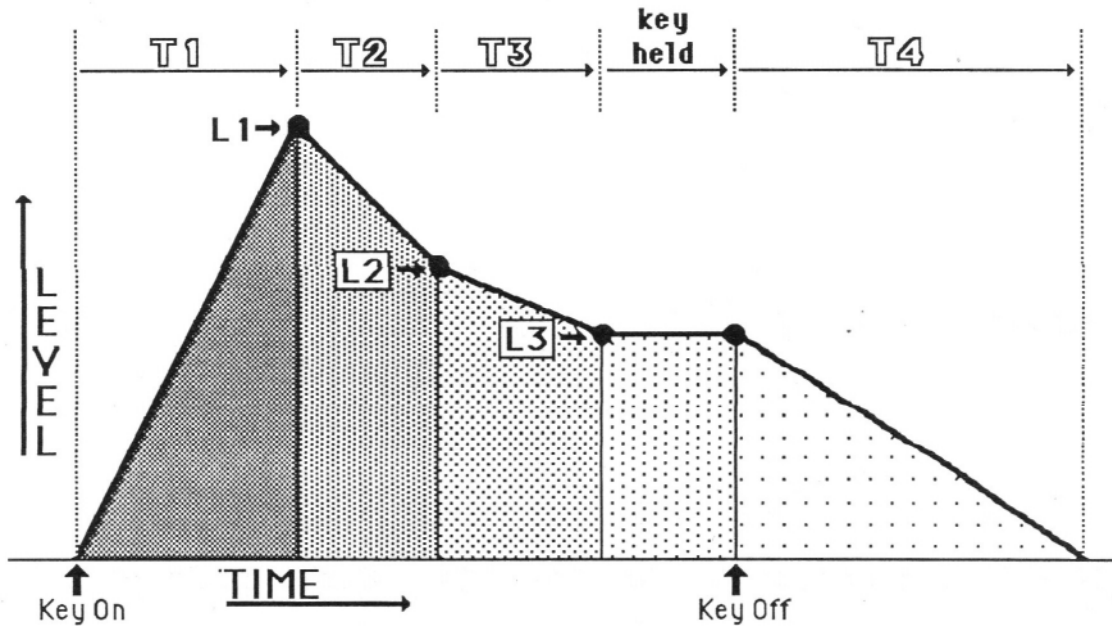

Notice that the Envelope shape depicted above resembles the ADSR Envelope discussed earlier. Though this is only one of many shapes that are possible with the ESQ-M Envelopes, it is one of the most useful for modulating the Volume and Brightness of a Sound.

If we now look at the ESQ-M Envelope parameters as they apply to this standard ADSR-type Envelope, we can see that **TIME 1** represents the attack time; **TIME 2** and **TIME 3**, a two-stage decay; and **TIME 4** represents the release time. **LEVEL 1** is the peak level; **LEVEL 2** is an intermediate decay level; and **LEVEL 3** is the sustain level.

Time, not Rate

It is very important to note that all of the Envelopes' Time components, **TIME 1**, **TIME 2**, **TIME 3** and **TIME 4** are expressed in terms of **Time, not Rate**. Thus, for example, when a key is struck the signal will always travel from Zero to **LEVEL 1** in the fixed amount of time defined by **TIME 1**. If the value of **LEVEL 1** is raised, the signal will still reach the new, higher, **LEVEL 1** in the same amount of time.

Negative Levels

In the sample Envelope shown above, all of the Level values were positive. But the ESQ-M also allows you to assign a negative value to any of the Envelope Levels, making possible a wide variety of interesting shapes. In the Envelope below, for example, **LEVEL 2** is given a value of -32.

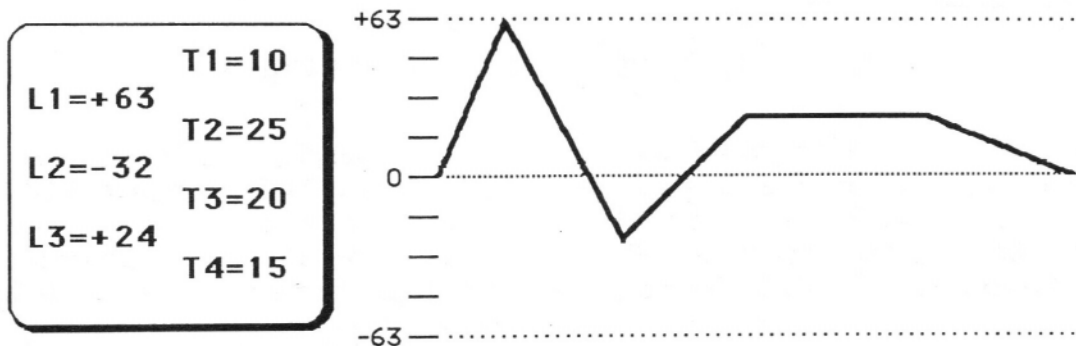

Example of Envelope with LEVEL 2 Negative

Such an Envelope allows you to modulate a signal to levels below the Manual settings, as well as above them. Say you apply the Envelope shown above as a modulator to the **Filter Cutoff Frequency**. If the Manual setting on the FILTER Page, (FREQ=_) is set for about 2 khz., modulating the **Filter Cutoff Frequency** with this Envelope would cause the **Filter** to behave like this:

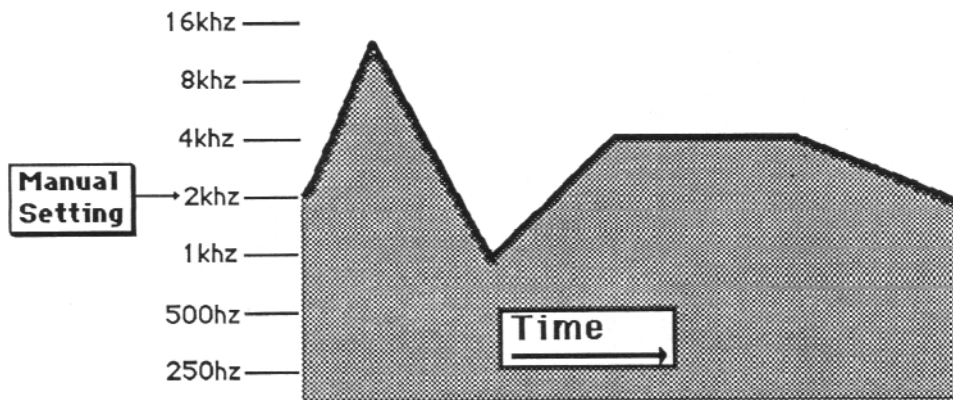

Filter Cutoff Frequency Modulated by a Complex Envelope

The extent of the effect in the example above would vary depending on the **Modulation depth**. Bear in mind that **Modulation depth** can also have a negative value. The combination of negative Envelope Levels and negative **Modulation depths** makes for almost infinite possibilities for controlling Pitch, Volume, Brightness, LFO depth, etc.

Other Envelope Shapes

There are many possibilities for creating interesting Envelopes — here are just a few. If **LEVEL 1** is set to Zero, then **TIME 1** becomes a delay, **TIME 2** the attack time, **LEVEL 2** the peak level, and so on. Such an Envelope, applied to one of the DCA's, would cause that Oscillator to "wait" before beginning to play.

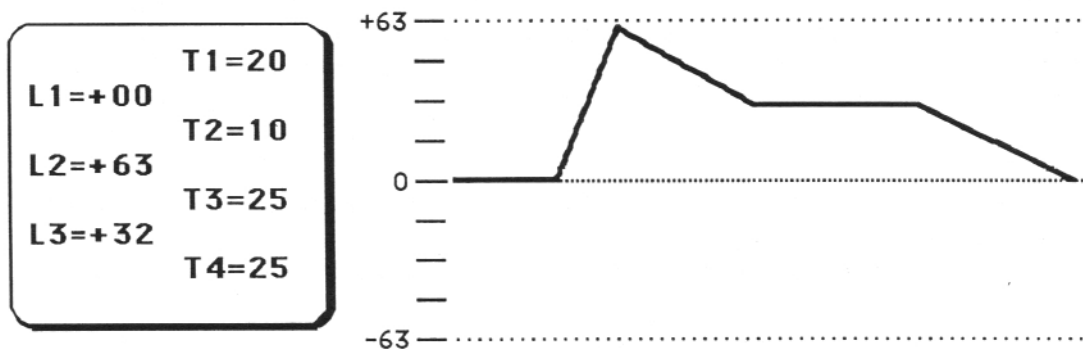

If LEVEL 1=0, TIME 1 Acts as a Delay

Another useful shape is a simple pitch Envelope. You can, for example, imitate the way Horns often "slide" into a note, rather than beginning right on pitch. By setting **TIME 1** to Zero, **LEVEL 1** to some negative value, and **LEVEL 2** and **LEVEL 3** to Zero, you now have an Envelope which, when used to modulate Oscillator Pitch, will cause the pitch to "slide" up to the proper note in the amount of time defined by **TIME 2**. The picture on the next page illustrates such a pitch envelope.

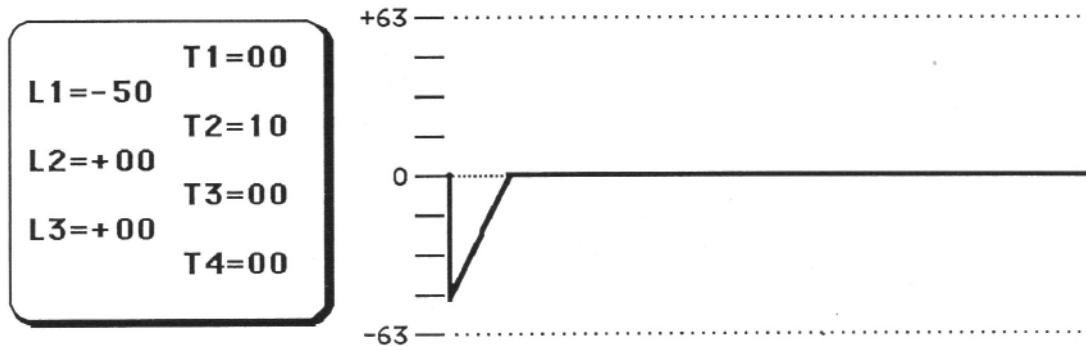

Rising Pitch Envelope

This could be a rather long, dramatic "slide", or an almost imperceptibly short one, depending on the value you assign to TIME 2. How much the Pitch is altered will depend on the value of LEVEL 1 and the Modulation depth.

VELOCITY CONTROL OF ENVELOPES

There are two parameters on the **Envelope** Page allow you to alter an Envelope depending on keyboard velocity, or how hard you strike a key.

[VEL LVL] — Velocity Level control

The first of these, **VEL LVL** or **Velocity Level Control**, will lower all three levels (**LEVEL 1**, **LEVEL 2** and **LEVEL 3**) with a softer keystrike. This means that the settings you assign to **LEVEL 1**, **LEVEL 2**, and **LEVEL 3** are maximum Levels, the Levels that will be reached with the hardest keystrike. The amount of **VEL LVL** determines how much those Levels will be reduced as you play softer.

With this parameter you can have continuous dynamic control over the three levels by varying how hard you play. The most common uses of the **Velocity Level Control** have to do with varying the volume and brightness of a Program, though in the previous example **VEL LVL** could be used to alter the depth of the **Pitch Envelope** with velocity.

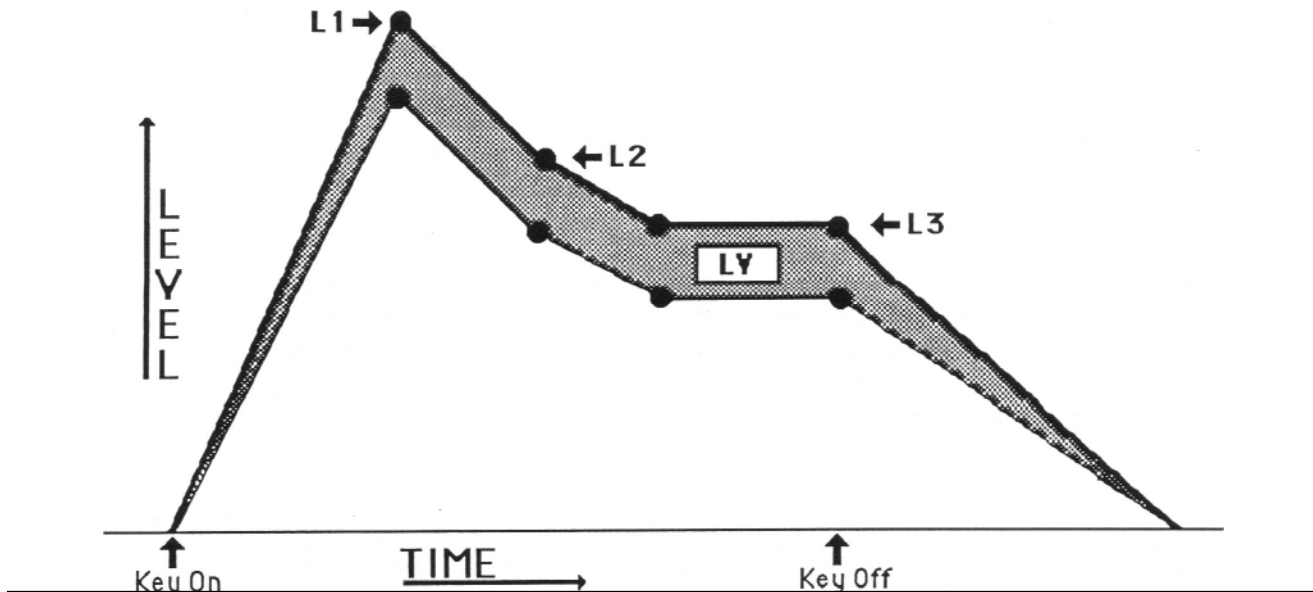

[VEL T1] — Velocity Attack control

The second velocity-related parameter is **VEL T1 — Velocity Attack Control**. As the name implies this parameter makes **TIME 1**, the Envelope attack time, respond to keyboard velocity. When the value of **VEL T1** is increased, a harder keystrike will decrease **TIME 1**, resulting in a faster attack.

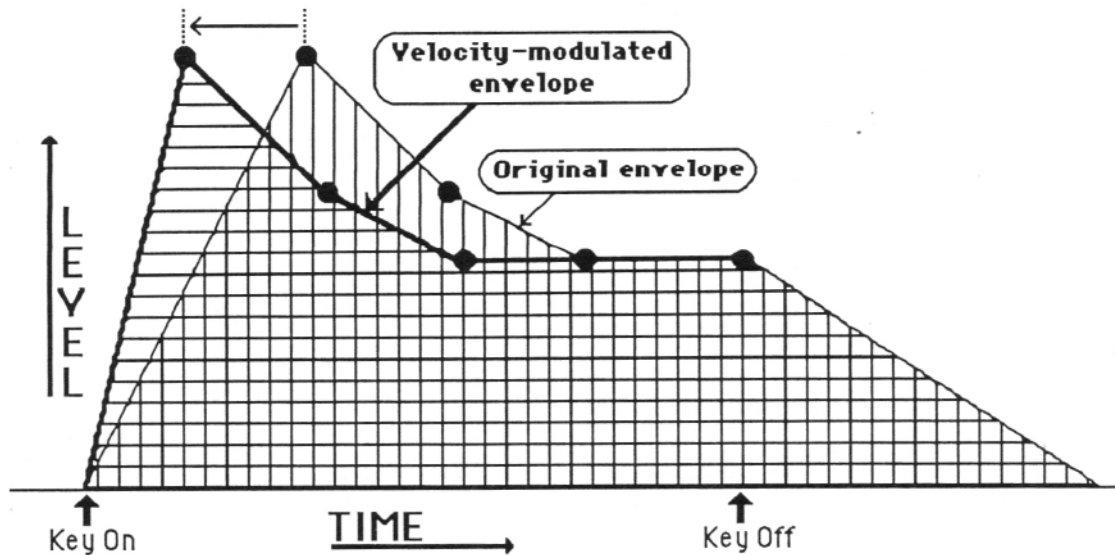

This allows for great expression on String sounds and the like, making it possible to have a long, smooth Attack or a sharp, crisp Attack simply by varying how hard you play. The greater the value of **VEL T1**, the more **TIME 1** will be decreased with velocity. If **TIME 1** already equals Zero, this parameter will have no effect.

[KBD SCAL] — Keyboard Decay Scaling

The final Envelope parameter is **KBD SCAL — Keyboard Decay Scaling**. Raising the value of **KBD SCAL** has the effect of decreasing **TIME 2** and **TIME 3** as you play higher up the Keyboard. Higher notes will therefore decay faster than lower ones. The higher the value assigned to **KBD SCAL**, the greater the difference in Decay Time between the highest and lowest notes. This is useful for simulating the Decay patterns of many acoustic instruments (piano, for instance) whose lower notes tend to ring much longer than the higher ones.

Note that if **TIME 2** and **TIME 3** both have a value of Zero, this parameter will have no effect.

Limits of Modulation

Note that for all Modulation effects there is a maximum and a minimum range that cannot be exceeded. For example, if the **Filter Cutoff Frequency** is manually set to its maximum value [127], you will not be able to modulate the Frequency any higher with an Envelope or other Modulator. You cannot modulate an Oscillator's Output Level lower than Zero (silence). If an Envelope or other Modulator doesn't seem to be having any effect, check that the other Modulators and manual settings are at appropriate levels.

ENVELOPE TIMES

The chart below gives the approximate amount of Time, in seconds, that corresponds to each possible value of the Time components of the Envelopes (**TIME 1**, **TIME 2**, **TIME 3** and **TIME 4**). The numbers in **bold** type are the values that can be assigned to **TIME 1**, **TIME 2**, **TIME 3** or **TIME 4**; the numbers in plain type show how long a Time each of those values will yield.

T=:	Time(sec.)	T=:	Time(sec.)	T=:	Time(sec.)	T=:	Time(sec.)
0	.00	16	.09	32	.57	48	3.62
1	.01	17	.10	33	.64	49	4.06
2	.01	18	.11	34	.72	50	4.56
3	.02	19	.13	35	.81	51	5.12
4	.02	20	.14	36	.91	52	5.75
5	.03	21	.16	37	1.02	53	6.45
6	.03	22	.18	38	1.14	54	7.24
7	.03	23	.20	39	1.28	55	8.13
8	.04	24	.23	40	1.44	56	9.12
9	.04	25	.25	41	1.61	57	10.24
10	.04	26	.29	42	1.81	58	11.49
11	.05	27	.32	43	2.03	59	12.90
12	.06	28	.36	44	2.28	60	14.48
13	.06	29	.40	45	2.56	61	16.25
14	.07	30	.45	46	2.87	62	18.25
15	.08	31	.51	47	3.23	63	20.48

Note: Envelope Times will be as shown above only when **KBD SCAL=00**, and **VEL T1=0**. These two parameters have the effect of decreasing Envelope Times (**KBD SCAL** based a note's position on the keyboard, and **VEL T1** based on Velocity.) If either has a value greater than Zero, **TIME 1**, **TIME 2** or **TIME 3** could be shorter than indicated by the chart, depending on where and how hard you play.

[ENV 1] ENVELOPE PAGE

[ENV 2]

[ENV 3]

[ENV 4]

Controls the parameters of the four Envelopes.

The format of the **Envelope Page** is the same for **ENV 1**, **ENV 2**, **ENV 3** and **ENV 4**, although each Page is independent. The **Envelopes** are used as Modulators, and may be applied wherever a **Modulation Source** is selected.

All **Envelope** parameters are expressed in terms of **TIME** and **LEVEL**. It is important to note that the Time components of the **Envelopes (TIME 1, TIME 2, TIME 3, and TIME 4)** each define a fixed Time, not a Rate. Thus, if you raise the value of **LEVEL 1** but leave **TIME 1** the same, the **Envelope** will still take the same amount of Time to reach the new, higher, **LEVEL 1**.

Also note that the Level parameters can be positive or negative. This allows for a wide variety of Envelope shapes, especially useful for modulating the **Filter** Frequency, **Oscillator** pitch, etc.

The Parameters on this Page can be selected by pressing **Scroll** until the desired parameter is showing or by entering the Parameter Number immediately selecting the Page.

ENV (1-4) PAGE									Parameters on this Page:
0	1	2	3	4	5	6	7	8	
LEVEL 1	LEVEL 2	LEVEL 3	VEL LVL	VEL T1	TIME 1	TIME 2	TIME 3	TIME 4	KBD9SCAL

0. LEVEL 1

This is the **LEVEL** that the Envelope will reach at the end of the Time defined by **TIME 1**. All Envelopes start at a level of Zero and proceed toward **LEVEL 1** when a key is pressed. Range: -63 To +63.

1. LEVEL 2

The **LEVEL** that the Envelope will reach at the end of **TIME 2**. Range: -63 To +63.

2. LEVEL 3

The **LEVEL** that the Envelope will reach at the end of **TIME 3**. This is the **Sustain** Level. The Envelope will remain at this level until the key is released. After the Key is released, the Envelope will return to Zero. Range: -63 To +63.

3. VEL LVL — Velocity Level Control

This parameter makes all three Levels, **LEVEL 1**, **LEVEL 2** and **LEVEL 3**, respond to Keyboard Velocity, or how hard you strike the key. When the value of **VEL LVL** is raised, a softer keystroke will decrease all three Levels. The greater the value, the more the Levels will decrease as you play softer. Thus the Levels set by **LEVEL 1**, **LEVEL 2** and **LEVEL 3** define the *maximum* Levels, and parameter **[VEL LVL]** *subtracts* from those Levels. Range: 0 To 63.

4. VEL T1 — Velocity Attack Control

This control makes **TIME 1** respond to Keyboard Velocity. Raising its value will cause a **decrease** in the value of **TIME 1** as a key is struck harder, shortening the Attack Time. The greater the value, the faster **LEVEL 1** will be reached with a hard keystrike. (This Parameter will have no effect if **TIME 1 = 0**.)

Range: 0 To **63**.

5. TIME 1

The amount of Time between when the key is struck and when the Envelope reaches **LEVEL 1**. In most applications this is the **Attack Time**. The higher the value the longer the TIME. Range: 0 To **63**.

6. TIME 2

The Time it takes the Envelope to go from **LEVEL 1** to **LEVEL 2**. In most applications this is the first of two Decay stages.

Range: 0 To **63**.

7. TIME 3

The Time it takes the Envelope to go from **LEVEL 2** to **LEVEL 3**. In most applications this is second Decay stage. At the end of **TIME 3**, the Envelope will remain at **LEVEL 3** until the key is released.

Range: 0 To **63**.

8. TIME 4

Release Time. Defines the amount of Time it will take the Envelope to return to Zero from **LEVEL 3** (or from whatever it currently is, if **LEVEL 3** has not yet been reached) after the key is released.

Range: 0 To **63**.

9. KBD SCAL — Keyboard Decay Scaling

Raising the value of this parameter will cause the value of both **TIME 2** and **TIME 3** to decrease as you go higher up the keyboard. Thus higher notes will decay faster than lower ones. This is true of many acoustic instruments. The greater the value of **KBD SCAL**, the more the decay time will **decrease** as you play higher up the keyboard. **KBD SCAL** will have no effect if **TIME 2** and **TIME 3** are Zero.

Range: 0 To **63**.

[MODES] MODES PAGE

Controls Glide, Sync, AM, and Mono Modes, as well as Voice, Envelope and Oscillator Restart Modes.

All of the Parameters on this Page are part of the **Program** (or patch), and will apply only to the selected Program.

The Parameters on this Page can be selected by pressing Scroll until the desired parameter is showing *or* by entering the Parameter Number immediately selecting the Page.

MODES PAGE		I Parameters on this Page:					
0	1	2	3	4	5	6	7
AM	GLIDE	MONO	SYNC	RST VC	RST ENV	RST OSC	ENV CYC

O. AM

Amplitude Modulation. When ON, the Amplitude of **Oscillator 1** modulates the Amplitude of **Oscillator 2**. OSC 2's Amplitude Envelope will be ignored. This results in the creation of "Sideband" frequencies at the sum and difference of the frequencies being played by the two Oscillators.

When **OSC 1** and OSC 2 are tuned to simple intervals of each other (such as octaves or fifths, etc.), AM Mode can produce FM-like enharmonics, for bell sounds, etc. When the Oscillators are tuned to more complex intervals, the effect is more extreme.

Since the Amplitude of **Oscillator 2** is no longer being controlled by DCA 2, you must use DCA 4 and ENV 4 to control the volume of the Sound.

1. GLIDE

Also called **Portamento**. This causes the pitch of the Oscillators to "glide" between notes instead of the usual abrupt transition. The higher the value, the longer it will take to get from the pitch of the first note played to that of the second. Range: 0 To **63**.

NOTE: The GLIDE function behaves in one of two ways, depending on whether or not **MONO mode** is engaged:

With **MONO mode OFF:** The pitch of any note played will 'glide' to its proper pitch from that of the note played immediately before it, at the rate that has been set. In this mode the GLIDE is **polyphonic**, and whole chords can be made to swoop up and down together. (Very dramatic.)

With **MONO mode ON:** You have what is called **Fingered Portamento**. If a key is pressed with no other keys held down, there is no **GLIDE**. If you then play a second key while holding down the first, the note will glide from the pitch of the first key to that of the second. Release the second key (still holding the first one down) and it glides back. In other words, **the effect is only present when a note is played while another key is held down**. You can thus play Staccato for runs without GLIDE, and Legato for runs with **GLIDE**.

2. MONO

In **MONO mode** the **ESQ 1** behaves like a classic one-voice Monophonic synth. It is useful with lead-type sounds where chords are not necessary or desirable. With **MONO mode ON**, only one note can be played at a time. Priority is given to the **last note** played -- even if another note is being held down, the most recent note you play will sound. However, the envelope will not be re-triggered by striking a key as long as any other key is held down. **Mono mode** on the **ESQ 1** does not stack all eight voices on one key -- only one voice plays.

3. SYNC

Syncs the phase of **Oscillator 2** to that of **Oscillator 1**. In other words, whenever OSC 1 finishes playing one complete cycle of its waveform and begins another, OSC 2 will reset to the beginning of its cycle, whether the previous cycle is complete or not.

This produces the popular "Hard Sync" effect, which can be similar to a Filter sweep. The effect is most noticeable when the Frequency of **Oscillator 2** is varied, or modulated.

NOTE: The next two Parameters (#4, [**RST VC**] VOICE Restart, and #5, [**RST ENV**] ENVELOPE Restart) affect only what happens when you play the same note twice in succession.

4. **RST VC --VOICE Restart**

When ON: If the same key is restruck before the note has died away, it will be assigned the same Voice that was previously playing it. That Voice will be 'stolen' to play the new note. This is fine for many sounds, such as piano, but it can be annoying with others, especially sounds with long Attack or Release times, like strings, where you don't necessarily want a note to abruptly disappear just because you have played the same note again.

When OFF: If a key is restruck before the note has died away, a new Voice will be assigned to it, and the first Voice will continue to play. If there are already two Voices playing that note, the older of the two is 'stolen'. (Two Voices will alternate playing the note if it is struck repeatedly.) As mentioned above, for sounds with long Attack or Release times (such as long filter sweeps, etc.) this is often better.

5. **RST ENV --ENVELOPE Restart.**

When ON: If the same key is restruck, all four Envelopes will reset, and start their cycles at Zero level.

When 01-1-: Each Envelope will start its cycle at its present level, regardless of what that level is, when the same note is played again. It will then take **TIME 1** to reach **LEVEL 1**, whether the new ramp is in the same direction (up or down) as the original attack segment or not. In other words, each Envelope behaves normally, except that its Starting Level, normally Zero, becomes whatever Level it was at when the key was restruck.

6. **RST OSC --Oscillator (Waveform) Restart**

When ON: All three Oscillators are halted before the start of a sound, and are restarted together when a key is struck, so that they will start out playing in phase with each other. Any phasing, or "beating" between the oscillators (due to detuning, etc.) will be the same each time a key is struck.

When OFF: The Oscillators are not stopped before a new note is played, but continue to play. Therefore the relative phase of the Oscillators will be unpredictable. This will tend to randomly vary the phase shift and tonal characteristics of the sound.

7. ENV CYC --Envelope Full Cycle Mode

When ON: The Envelopes will pass through their full cycles every time a key is struck. In this Mode the **ESQ 1** pays no attention to whether you hold the key down or let it go immediately — each Envelope simply 'runs' through all its stages (ignoring the sustain stage after TIME 3) with each keystrike. This can be useful for many percussion-type sounds, bell sounds, filter sweeps and other sounds where you want consistently repeatable Envelopes that are not dependent on keyboard technique.

When OFF: This is the Normal Mode of operation. All Envelopes will reset and begin their cycles from Zero whenever a new key is struck.

[SPLIT/LAYER] Split/Layer PAGE

Controls Splitting the Keyboard and Layering Different Sounds together

Programs on the ESQ-M can be Layered (so that two Programs play at once over the whole keyboard), **Split** (so that each half of the keyboard plays a different Program), and **Split/Layered** (so that the **Split** Program is layered with yet another Program).

It is important to note that the parameters on this Page are all **part of the Program** — that is, any **Split** and/or Layer configurations you set up here must be Saved as part of a new Program in order to be retained. For example, if you start with a Piano Program, and then Layer that with a String Program, you can now save the new Layered combination in a new Location — the original String and Piano Sounds will remain intact in their original locations. You can select this Layered combination whenever you want it, just as you would any other Program.

Also bear in mind that wherever two Programs are Layered, the ESQ-M becomes a four-voice Synthesizer — it will start "stealing" voices after four have been played, rather than the usual eight. A Split, on the other hand, doesn't cause any loss of voices.

The Parameters on this Page can be selected by pressing Scroll until the desired parameter is showing *or* by entering the Parameter Number immediately selecting the Page.

Use this Page to:

- Activate the Layer function;
- Choose the **Layer Program**;
- **Split** the Keyboard (Upper or Lower) between two different Programs;
- Choose the **Split Program**;
- Choose the **Split Key**;
- Layer a second Sound with the Split Program (**Split/Layer** mode); and
- Choose the **Split/Layer Program**.

SPLIT/LAYER PAGE I Parameters on this Page:

0	1	2	3	4	5	
SP/LA sw	SP/LA prog	LAYER sw	LAYER prog	SPLIT sw	SPLIT prog	SPLIT KEY

0. SP/LA (switch) — SPLIT/LAYER ON/OFF

This activates the Split/Layer mode. In order for this control to have any effect, the Keyboard must first be Split, either Upper or Lower (see #4 below).

When ON: The **Split Program** will be Layered (will play simultaneously) with the Program selected by the next parameter (#1). This will result in a reduction to four Voices only on the **SPLIT/LAYERED** half of the Keyboard.

1. SP/LA (prog) — Select SPLIT/LAYER Program

The Program whose name appears here will be Layered with the **Split Program** when an Upper or Lower Keyboard Split has been selected. It is possible to have a **Split/Layer** without Layer mode being on. The Program shown here is Layered only with the **Split Program**. There will always be a Program name in this Location, whether the Layer mode is engaged or not.

When this control is selected, you can choose a new **SPLIT/LAYER Program** by using the Data Entry Slider and the Up and Down Arrow Buttons to browse through the various Programs in Memory until you find the one you want.

- 2. **LAYER (switch) — Layer On/Off** This acts as a switch to turn On or Off the Layer mode.

When ON: The Current Program (the one you are editing) will be Layered (combined) with the Program selected by the next parameter (#3), and both Programs will play simultaneously. Activating the Layer mode reduces the number of available Voices to four (from eight) wherever a layer is selected.

- 3. **LAYER (prog) — Select LAYER Program**

The Program whose name appears here will be Layered with the Current Program when the Layer mode is switched On. There will always be a Program name in this Location, whether the Layer mode is engaged or not.

When this control is selected, you can choose a new **LAYER Program** by using the Data Entry Slider and the Up and Down Arrow Buttons to scroll through the various Programs in Memory until you find the one you want.

- 4. **SPLIT (switch) — SPLIT ON/OFF**

This control is used to **Split** the Keyboard between two Programs, as well as to determine which Keyboard half each will occupy. There are three possible states:

----> **OFF** — Normal Keyboard assignment; no Split.

----> **UPPER** — When **SPLIT=UPPER** is selected, the **Split Program** (see #5) will play on the Upper Keyboard (that is, above the **Split Key**), and the Current Program will play on the Lower Keyboard (below the **Split Key**).

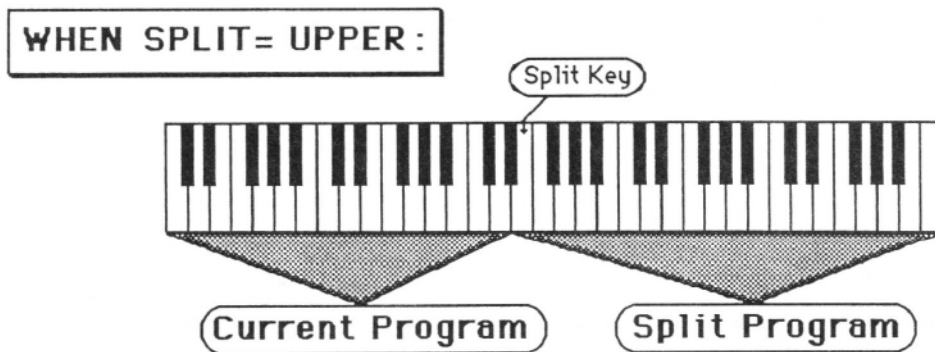

----> **LOWER** — When **SPLIT=LOWER** is selected, the **Split Program** will play on the Lower Keyboard (that is, below the **Split Key**), and the Current Program will play on the Upper Keyboard (above the **Split Key**).

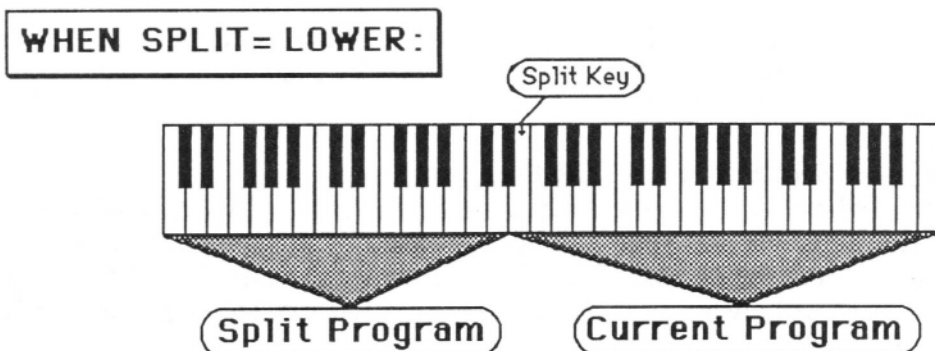

So when you select UPPER or LOWER here, you are selecting which area of the Keyboard the **Split Program** will occupy. The Current Program (the one you started from) will always occupy the the opposite Keyboard half.

5. SPLIT (prog) — Select SPLIT Program

The Program whose name appears here will occupy the half of the Keyboard as designated above (#6), if **SPLIT=UPPER** or **SPLIT=LOWER** has been selected. There will always be a Program name in this Location, whether the Split mode is engaged or not. When this control is selected, you can choose a new SPLIT Program by

using the Data Entry

Slider and the Up and Down Arrow Buttons to browse through the various Programs in Memory until you find the one you want.

AN IMPORTANT NOTE ABOUT SPLITS AND LAYERS:

Whenever you select a **Layer Program**, a **Split Program**, or a **Split/Layer Program**, the ESQ-M only "remembers" the Location of that Program in Internal or Cartridge Memory — not the Program itself. If you move a Program, put another in its place, or transfer an entire Bank of Programs, the **Layer, Split**, or Split/Layer Program on this Page might still be "pointing to" a Location that no longer contains the sound you had in mind.

For example, if you create and save a Program where a Brass sound is Layered with a String sound, and you then Write over the String Program (or insert a different Cartridge in the case of Layering with a Cartridge Program,) a different Layer Program will play — whatever is now in the Location originally occupied by the String sound.

If your **Layer, Split**, or Split/Layer Program is a Cartridge Program, and you remove the Cartridge, the word *CART* will appear instead of the Program name, and the Program that will play will be the Internal Program with the same relative Memory Location (until you replace the Cartridge).

This also means that if you transfer an entire Bank of Programs from a Cartridge to the Internal Memory (or vice versa), any **Layer, Split**, and Split/Layer Programs will still be "pointing to" their previous Locations, and may not work once the Cartridge is removed, or you insert a different Cartridge. In this case, you should go through the transferred Programs and edit them so that the **Layer, Split**, and Split/Layer Programs are in the new Bank, and then Save (Write) the Programs back into their current Locations

Note also that if you select a Program for your Layer, **Split**, or Split/Layer Program that itself contains a Layer, or Split, only the main part of that Program will play — not any Layers or Splits that are programmed into it. It is only possible for one **Layer, Split**, or **Split/Layer** to be active at any time. So you can't, for example, make a Triple Layer by selecting an already-Layered Program as the Layer Program.

6. SPLITKEY — Select SPLIT Key

This designates the note on the keyboard at which the Programs will **Split**, if **SPLIT=UPPER** or **SPLIT=LOWER** has been selected (#4 above).

Range: 21 To 108.

Key Numbers given here are **MIDI key Numbers** — they reflect the MIDI standard for numbering keys, rather than just counting up from the lowest note on a keyboard. Thus the Low C on a 5-octave (61-note) keyboard is MIDI Key # 36; Middle C is MIDI Key # 60; the High C is MIDI key # 96.

The available range of values (**21 To 108**) corresponds to the the 88 key range of a grand piano. This allows the Split Key to actually be out of the range of a 61-note keyboard such as the ESQ-1. Splits with a Split Key lower than 37 will only be effective if the ESQ-M is played via MIDI from an instrument with more than a 61-note keyboard. The **Split Key** itself always plays whichever Program is on the Upper half.

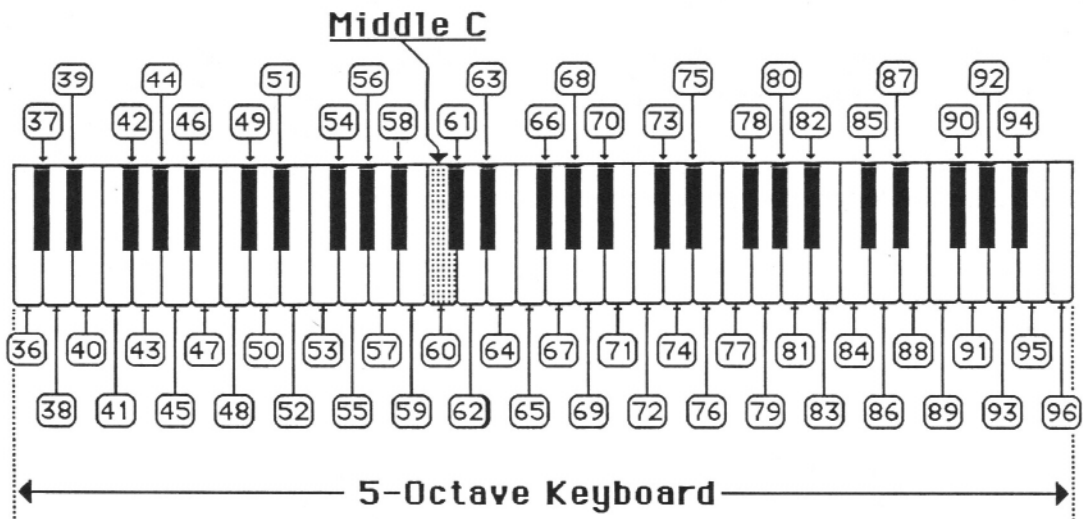

PROGRAMMING CONVENTIONS

There are a number of Programming conventions that have been followed within the **ESQ 1** factory Programs. They will help you to know where to begin when editing factory Programs. You may also find them to be handy rules of thumb to follow when creating your own Programs.

LFO's

----> **LFO 1** is used for Wheel Vibrato, when it is part of the Program.
LFO 2 and LFO 3 are available for other purposes.

Envelopes

----> **ENV 1** is used for Pitch Envelopes (modulating **OSC 1, 2 or 3.**)
ENV 2 is used for individual volume Envelopes (modulating **DCA 1, 2 or 3.**) ENV
3 is used for Filter Envelopes (modulating the **Filter Cutoff Frequency.**) ENV 4
is always fixed as the overall volume Envelope (DCA 4.)

Of course these do not all apply for every Program. Any Envelope can be routed anywhere you want it to go (except to DCA 4), and some Programs will call for different applications. But where applicable, the factory Programs follow these conventions.

Program Names

----> (/) Where a Program is Layered, a slash (/) is incorporated into the Name.
----> (+) Where a Program contains a Split, a plus sign (+) is incorporated into the Name.

*Page
Intentionally
Left Blank*

Section 5 — Saving and Storing Programs (and "Hidden" Functions)

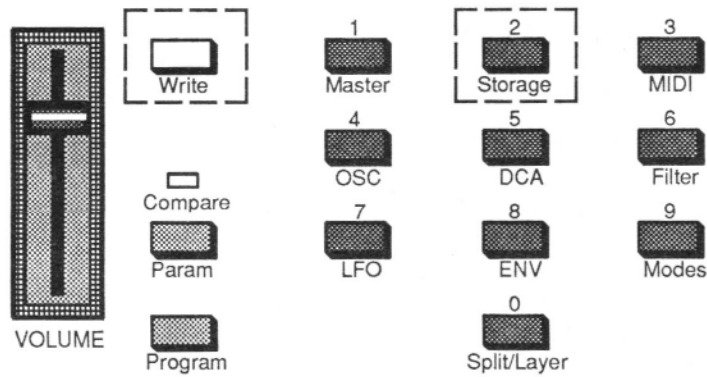

[WRITE] WRITE PAGE

To Save a New or Edited Program into Memory, or Copy an Existing Program to another Location.

SAVING A NEW PROGRAM INTO MEMORY

Once you have modified an existing **Program**, or created an entirely new one, you can Write, or save, that Program to any Internal or Cartridge Memory Location using the **WRITE** Page. This Page is also used to rename the Program with the name of your choice.

Before you start the Write procedure, you should determine which Internal or Cartridge Program you want to replace with the new Program. Find the Program you want to overwrite, and make a note of its
 Program Number.

Next, decide on a Name of up to six letters for your new Program. Then:

1. **Make sure the yellow Compare light is lit.** If it isn't, press the **Param** button until it lights. This ensures that the Program you are saving is the modified version (the Edit Program).
2. **Press the white button labeled WRITE on the front Panel to select the WRITE Page.** The Page will come up as shown below, with the current Program Name showing. You will notice that the first letter of that Name is flashing. This means that it is ready to be changed.

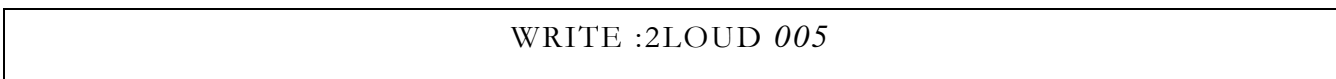

3. **Edit the Program Name** using the **Data Entry Slider** and the Scroll button. You can move the **Data Entry Slider** up and down to browse through the available characters, or step through them one at a time with the Up and **Down Arrow** buttons. Experiment until you find the first letter you want. Then press the Scroll button. The next location in the name begins flashing, meaning that it is ready to be edited. Again, move through the characters until you find the correct one. Repeat this procedure until the display shows the name you have chosen.

You can select the letter to the right by pressing Scroll, the one to the left by pressing the **Down Arrow** button while holding down the Scroll button. Repeat this procedure, changing letters as often as you like, until you're satisfied with the name. There are some pretty weird characters in there, along with the usual letters and numbers, to choose from. Be creative.

Helpful Hint: Moving the **Data Entry Slider** all the way down gives you a blank space. Note also that when there is a blank space in a Program name, and the blank space is selected, it is represented by a flashing underline character. (A flashing blank space, while perhaps interesting as a Zen exercise, would not be an easy concept to represent.) When you press **Scroll** to move to the next character, the flashing underline will indeed appear as a blank space.

4. **Press the Scroll button until the Program number is flashing.** In order to write the new Program into memory, the three digit Program number on the right side of the display must be selected (flashing).
5. **Adjust the Data Entry Slider and/or the Up and Down Arrow buttons until the display shows the Program number you want to save the new Program to.** (Remember that you will be replacing whatever is already there, so be sure you have the one you want.)

Or,
Type in the Program number directly from the numeric keypad. You can enter a three-digit Program number (from 001 to 040 for the Internal memory locations, and from 041 to 120 for

the Cartridge locations) any time you are on the Write Page. The number doesn't have to be flashing for you to do this. Remember that you must enter all three digits, including the initial zero (0) in Program numbers below 100. (Example: to enter Program # 030, press "zero, three, zero.")

6. **Press the Write button to write the Program into Memory.** Once you have the proper Program number showing, and *while that number is flashing*, press the Write button. This writes the new Program, with its new Name, into that Memory Location. The Display will show a **message:**

WRITING PROGRAM

which will remain for about two seconds. It will then return to the **Program** Page. The new **Program** is selected as the Current **Program**:

TRK 0 22LOUD 005

BAILING OUT

If **you** need to exit the Write Page, either to check through the Programs in memory in order to find one to overwrite, or because you pressed **Write** by mistake, simply press the **Program** or **Param** button. This returns the ESQ-M to normal operation.

COPYING AN EXISTING PROGRAM TO ANOTHER LOCATION

Sometimes you'll want to take an existing Program, one that you haven't been editing, and simply copy it to another Memory Location. For example, you might want to put your ten most commonly used Programs in the first ten memory locations, for easy access during performance. Normally, the WRITE Page "looks" at the Edit Buffer. But you have the option of Writing an existing, unedited Program.

1. **First select the Program you want to copy.** Press the **Program** Button to put the ESQ-M in Program mode. The name of the Program you want to copy should be showing on the display. The yellow Compare light should not be lit. If it is, press the **Param/Compare** button until it goes out.
2. **Press the WRITE Button.** Pressing the WRITE Button when the yellow **Compare** light is not lit causes the ESQ-M to ask you if you want to replace the Edit Program with the Current Program:

REPLACE EDIT PRG

- 3_ **Press the Up Arrow/Yes button to place the Current Program onto the WRITE**

Page. You can now use the WRITE Page exactly as before to copy that Program to any other Memory Location. Again, remember that you will erase whatever Program you write over -- it's not a bad idea to save all Internal Programs to a Cartridge (or to another ESQ or a computer via MIDI) before doing any major Memory reshuffling, because once a Program is gone, it's gone.

Pressing the **Down Arrow/No** button in response to the question "REPLACE EDIT PRG" will put you on the **WRITE** Page with the Edit Program selected.

Pressing the **Program** button in response to the question "REPLACE EDIT PRG" will put you back in Program mode, and will not affect what is in the Edit Buffer.

[STORAGE] STORAGE PAGE — DATA TRANSFER

For Saving and Loading Programs to Cartridge or Over MIDI.

The **Storage** Page is used to send and load Programs to various media for saving and storage. The Storage Page handles two basic types of Program Data transfer:

1. **MIDI** -- All 40 Internal Programs, or any single Internal or Cartridge Program, can be sent via MIDI to another ESQ-M, an ESQ-1, or a Computer which is running the proper librarian software.
2. **CARTRIDGE** -- An entire Master Bank (all 40 Programs) can be transferred from the Internal Memory to CART A or CART B. Or the 40 Programs in CART A or CART B can be transferred to the Internal Memory.

All the commands on the **Storage** Page are initiated in the same way:

1. Select the Storage Page,
2. Press Scroll until the function you want is showing on the Display, and then
3. Press the Storage button *while holding down the Scroll button* to execute the function

MIDI TRANSFER OF PROGRAMS

The ESQ-M can be instructed to send Program Data over MIDI to another ESQ-M or ESQ-1. This Data could also be received by a Computer which has been programmed to receive such Data. Here we are concerned with sending Programs from one ESQ (the Sending Unit) to another (the Receiving Unit).

MIDI Connections

In the case of Sending Program Data via MIDI, it is only necessary that the **MIDI Out** jack of the Sending ESQ be connected to the **MIDI In** jack of the Receiving Unit. Three other conditions must be met:

1. Both Units must be set to the same **Base MIDI Channel**. (**MIDI** Page) MIDI Mode doesn't matter.
2. The Receiving Unit must have System Exclusive messages Enabled. (On the MIDI Page, set MIDI Enables to **ENBL=KCPSYS**.)
3. The Receiving Unit must be on a **Program** Page when receiving the Programs. Just press the **Program** button to put the receiving ESQ-M in Program mode before initiating the procedure.

PROG TO MIDI — Sending One Program via MIDI to another ESQ-M or ESQ-1

This will Send the current Program of the Sending Unit to the Edit Buffer of the Receiving Unit, replacing whatever is there.

----> Connect the MIDI cable, and set up the units as described above.

----> On the Sending Unit, press the **Param** button to put the ESQ-M in Parameter mode. ---

-> Select the **Storage** Page. The Display reads:

ST PROG TO MIDI

"ST" means Storage Page. "PROG TO MIDI" means "send the current Program via MIDI."
(This function always comes up first when you select the Storage Page.)

To initiate the procedure press the **Storage** button *while holding down the Scroll button*.

The Display will flash "**MIDI DATA XFER**" (You may not even notice it — one Program doesn't take long)

- > The Display will say "**DATA XFER DONE,**" and then return to the **Storage** Page. The new Program is now on the Write Page of the Receiving Unit. Edit its Name if you wish, and then Write it into Memory as described earlier (Write Page, p. 84).
- > If the Receiving Unit does not respond, check 1) your MIDI connections, 2) the MIDI Channel on both units, and 3) the MIDI Enables on the Receiving Unit, and try again.

BANK TO MIDI — Sending All Internal Programs to another ESQ-M or ESQ-1

This will Send the Internal Memory (all 40 Programs) of the Sending Unit to the Internal Memory of the Receiving Unit, replacing whatever is there.

Connect the MIDI cable, and set up the units as described earlier.

On the Sending Unit, press the **Param** button to put the ESQ-M in Parameter mode.

Select the **Storage** Page.

Press the Scroll button until the Display reads:

ST BANK TO MIDI

To initiate the procedure press the **Storage** button *while holding down the Scroll button*. While the transfer is in progress (about 3 seconds), the Display will read "**MIDI DATA XFER.**"

When the transfer is complete the Display will say "**DATA XFER DONE,**" and then return to the **Storage** Page. The 40 Internal Programs from the Sending unit are now in the Internal Memory of the Receiving Unit. Remember, this wipes out any Programs that were in the memory of the Receiving unit.

If the Receiving Unit does not respond, check 1) your MIDI connections, 2) the MIDI Channel on both units, and 3) the MIDI Enables on the Receiving Unit, and try again.

CARTRIDGE -- Bank Copy

The four **Bank Copy** functions let you transfer entire Master Banks (Internal, CART A, or CART B) between the ESQ-M and an ENSONIQ E² PROM Storage Cartridge.

TRANSFERRING CARTRIDGE PROGRAMS TO INTERNAL MEMORY

To Transfer all 40 CART A Programs to the INTERNAL Memory:

----> Insert an ENSONIQ E² PROM Storage Cartridge in the Program Cartridge Slot. ---->

Press the **Param** button to put the ESQ-M in Parameter mode.

----> Select the **Storage** Page.

----> Press the **Scroll** button until the Display reads:

ST CART A TO INT

To initiate the procedure press the **Storage** button *while holding down the Scroll button*.

While the transfer is in progress, the Display will read "**COPYING PROGRAMS.**"

Copying an entire Bank from a Cartridge to the Internal Memory takes only about two seconds. When the transfer is complete the ESQ-M will return to the **Storage** Page. The 40 Cart A Programs are now in the Internal Memory of the ESQ-M.

To Transfer all 40 CART B Programs to the INTERNAL Memory:

----> Insert an ENSONIQ E² PROM Storage Cartridge in the Program Cartridge Slot. Press the **Param** button to put the ESQ-M in Parameter mode.
Select the Storage Page.
Press the Scroll button until the Display reads:

ST CART B TO INT

To initiate the procedure press the **Storage** button *while holding down the Scroll button*.
While the transfer is in progress, the Display will read "**COPYING PROGRAMS.**" Copying an entire Bank from a Cartridge to the Internal Memory takes only about two seconds. When the transfer is complete the ESQ-M will return to the **Storage** Page. The 40 Cart B Programs are now in the Internal Memory of the **ESQ-M**.

TRANSFERRING INTERNAL PROGRAMS TO A CARTRIDGE

To Transfer all 40 INTERNAL Programs to CART A:

Insert an ENSONIQ E² PROM Storage Cartridge in the Program Cartridge Slot with the label facing down, and the writing on the end right-side-up.
Press the **Param** button to put the ESQ-M in Parameter mode.
Select the **Storage** Page.
Press the Scroll button until the Display reads:

ST I NT TO CART A

To initiate the procedure press the **Storage** button *while holding down the Scroll button*.
While the transfer is in progress, the Display will read "**COPYING PROGRAMS.**" Copying an entire Bank to the Cartridge takes about two minutes.
When the transfer is complete the ESQ-M will return to the **Storage** Page. The 40 Internal Programs from the Internal Memory are now in Bank A of the Cartridge.

To Transfer all 40 INTERNAL Programs to CART B:

Insert an ENSONIQ E² PROM Storage Cartridge in the Program Cartridge Slot. Press the **Param** button to put the ESQ-M in Parameter mode.
Select the Storage Page.
Press the **Scroll** button until the Display reads:

ST I NT TO CART B

To initiate the procedure press the **Storage** button *while holding down the Scroll button*.
While the transfer is in progress, the Display will read "**COPYING PROGRAMS.**" Copying an entire Bank to the Cartridge takes about two minutes.
When the transfer is complete the ESQ-M will return to the **Storage** Page. The 40 Internal Programs from the Internal Memory are now in Bank B of the Cartridge.

"HIDDEN" FUNCTIONS

There are five "hidden" functions on the ESQ-M which are accessed through the **Storage** Page. These functions are buried because they aren't really necessary for everyday operation of the ESQ-M and one of them, the MEMORY RESET function, will wipe out the contents of the ESQ-M's memory. These parameters are not for the timid. Each, however, is useful in certain situations.

HOW TO FIND THEM

The Hidden functions are activated from the Storage Page. To make them appear:

1. Press the **Param** button to put the ESQ-M in Parameter mode.
2. Press the Storage button go to the **Storage** Page.
3. Press and hold down the Scroll button. *While holding down the Scroll button*, press the **Master** button.

This puts the five hidden functions, starting with **Soft Reset**, into the parameter loop along with with the six functions normally available on the **Storage** Page. In other words, pressing Scroll will now scroll continuously through the usual Storage Page controls in addition to the five hidden functions. These functions are executed in the same way as other **Storage** Page functions — by pressing **Storage** while holding down the Scroll button.

The extra functions will remain visible until you exit the Storage Page, either by pressing the **Program** button or by selecting another parameter Page. To get them back into the loop once you have exited the Storage Page you must repeat the above procedure.

FUNCTIONS

The five "Hidden" Functions are as follows:

SOFT RESET

Soft Reset has the same effect as turning the ESQ-M's power off and then on again. Let's face it — there *are* those rare occasions when MIDI gets totally out of control and notes mysteriously hang, or some modulation effect just won't go away. You can cure many of those problems by turning an instrument off and then back on. Soft Reset does the same thing without your having to switch the ESQ-M off. It doesn't affect the ESQ-M's Program memory or change any parameter values, except that if System Exclusives were enabled (on the MIDI Page) when you reset, they won't be enabled when the ESQ-M comes back on (this is also the case when you switch the power off).

To execute the Soft Reset:

- With **SOFT RESET** showing on the Display,
 - Press the Storage button *while holding down the Scroll button*.. The ESQ-M will act just like it does when you turn it on, displaying its customary wake-up screen for several seconds and then returning to Program mode.

SOFTWARE VERSION

This control simply shows you which version of the ESQ-M software you have in your machine. As with any computer device, the ESQ-M's software is subject to being updated from time to time to in order to enhance the product.

To see what software version you have:

- With **SOFTWARE VER** showing on the Display,
 - Press the **Storage** button *while holding down the Scroll button*.. The Display will show the version number (as "**ESQ-M VER X.YZ**") for about two seconds and then return to the **Storage** Page.
-

MEMORY RESET

Also referred to as re-initializing the ESQ-M. This is one function you do not want to treat lightly. Memory Reset will erase all the Internal Programs, and reset all "Global" parameters to their default, fresh-out-of-the-box, values. It is primarily used by service personnel after performing operations which can scramble the unit's memory, such as replacing the O.S. ROM.

Memory Reset should only be used as a last resort in case the ESQ-M's software should become hopelessly confused, and a Soft Reset (or turning the unit off and on again) won't solve the problem. **Remember that this will wipe out all your Internal Programs and reset all Global parameters.** Because of this, an extra Are-You-Sure step has been added to the procedure for initiating the function.

To Reset all Memory:

- With **MEMORY RESET** showing on the Display,
- Press the **Storage** button *while holding down the Scroll button*.. The Display will ask:

RESET ALL MEMORY

- Press the **Up Arrow/Yes** button to Reset the Memory. The ESQ-M will display its wake-up screen for several seconds and then return to Program mode. All 40 Internal Programs will be reset to the default Program, **BRASS1**. All Global parameters will be reset to their default values. Or:
- Press the **Down Arrow/No** button to abort the procedure and return to the **Storage** Page with the **ESQ-M's** Internal Memory intact.
- After re-initializing the ESQ-M in this way, you should then tune the Filters (see below).

FILTER TUNE

The ESQ-M has eight Filters (one for each voice). They are tuned at the Factory and don't need to be bothered with unless you have re-initialized the unit. This procedure lets the software test the filters one at a time and then set the Cutoff Frequency for each one so that they will all behave the same.

To Tune the Filters:

- With **FILTER TUNE** showing on the Display,
- Press the **Storage** button *while holding down the Scroll button*.. You will see the ESQ-M test the eight filters in succession, displaying a number for each. The whole procedure takes about 18 seconds. If all is well, when it is finished the Display will read "**8 FILTERS TUNED**" and then return to the **Storage** Page.
- If any of the Filters cannot be tuned, the Display will "get stuck" on that Filter and never proceed to the next one. This would indicate a hardware problem. If this happens, turn the ESQ-M's power Off and take the unit to an authorized ENSONIQ Repair Station for service.

ANALOG TESTS

This Page is used by service personnel to test certain analog signals and MIDI functions within the ESQ-M and to check the Battery voltage. To activate the Analog Test Page:

- With **ANALOG TESTS** showing on the Display,
- Press the **Storage** button *while holding down the Scroll button*.. The Display will show the values for the Data Entry Slider (**D=nnn**), the Foot Pedal Input (**P=nnn**), and the Battery (**B=nn**) The ESQ-M's software will "read" the value of each 4 times per second. Also, the ESQ-M will play notes in an ascending chromatic scale out MIDI.
- The only reading here that is of real concern to you is the Battery reading on the right-hand side. It should read "**B=00.**" Any reading above zero indicated that the Battery is getting low and the ESQ-M should be taken to an authorized ENSONIQ Repair Station to have it replaced.
- Press any button (except **Scroll**) to exit this mode.

Section 6 — Applications

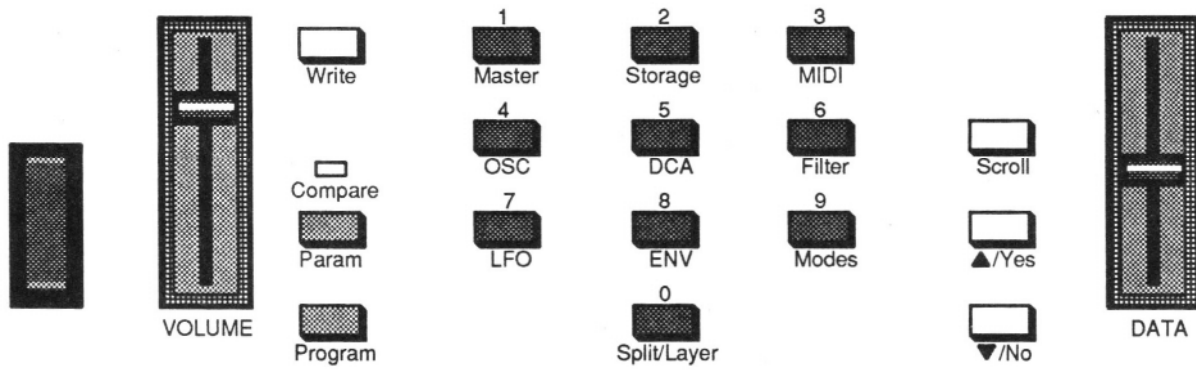

*Page
Intentionally
Left Blank*

USING THE ESQ-M WITH A SEQUENCER

Because of its multi-timbral capabilities, the ESQ-M is an ideal instrument for use with a MIDI sequencer. Its ability to "listen to" nine MIDI Channels at once means that the ESQ-M can take the place of several synthesizers in your rig. If you haven't already done so, you should read the sections in this manual entitled "More About Tracks" (pp. 21-22) and "MIDI Page" (pp. 32-38) for a fuller understanding of the ESQ-M's MIDI controls and how to configure them to your particular needs.

CONNECTIONS

The illustration to the right shows a typical sequencing set-up. Of course the ESQ-M doesn't have to be first in the chain after the sequencer — you can chain MIDI instruments in any order, with one exception. If any of the units doesn't have a MIDI Thru jack, you must place that unit last in the chain. (Or you could get a MIDI Thru Box, available from a number of manufacturers, which will split up the MIDI signal and send it to several devices at once.)

Also, some instruments (particularly those with a switchable MIDI Out/Thru jack) can impart a small amount of delay when passing along the MIDI signal. This usually poses a problem only if you are using a great many devices at once. Again, placing such instruments last in the chain or using a MIDI Thru box will minimize the effect.

THE ESQ-M AS ONE SYNTHESIZER

We'll start with the most basic sequencing situation, in which you will use the ESQ-M as if it were an ordinary synth, capable of playing only one sound at a time.

This is how it will act in POLY mode. In POLY Mode the ESQ-M will respond only to information received on the Base MIDI Channel, and will play only the sound which is on the current Track.

- On the MIDI Page, set the MIDI Mode parameter to **MODE=POLY**.
- Also on the MIDI Page, set the MIDI Channel (BASECHAN=) to whichever of the 16 MIDI Channels you want the ESQ-M to receive on. (It's already set to BASECHAN=1 unless you've changed it.) The ESQ-M will respond only to data received on this MIDI Channel.

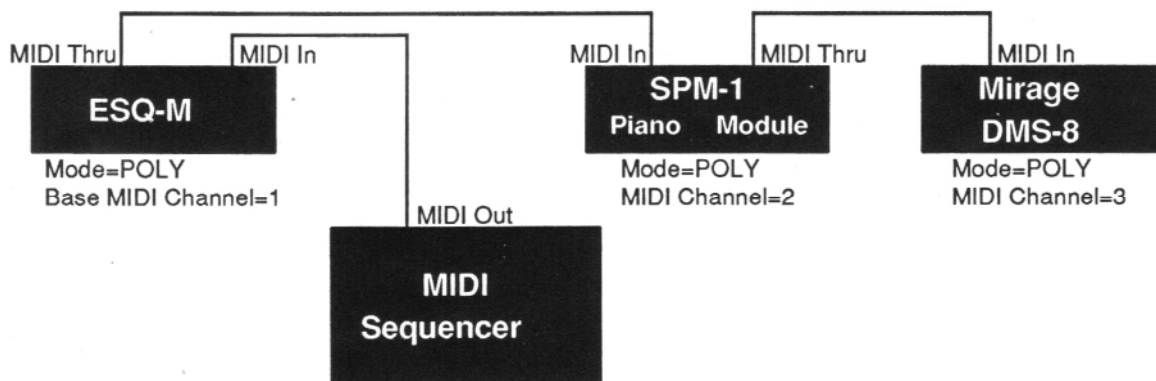

In the example above we have a sequencer connected to an **ESQ-M**, a **Mirage** Digital Multisampler and a **SPM-1** Sampled Piano module. With the **ESQ-M** in POLY Mode and set to BASECHAN=1, it will play information received on MIDI Channel 1. The SPM-1 will respond to information on MIDI

Channel 2, the Mirage to information on MIDI Channel 3. With this set-up you can send Keys, Controllers and Program Changes independently to each unit by sending on the proper MIDI Channel.

THE ESQ-M AS NINE SYNTHESIZERS

As we have discussed earlier, when you select MULTI Mode on the MIDI Page the ESQ-M becomes nine "virtual synthesizers," each receiving on its own MIDI Channel, but all sharing the same eight voices

- On the MIDI Page, set the MIDI Mode parameter to **MODE=MULTI**.
- Also on the MIDI Page, set the MIDI Channel for each Track to whichever of the 16 MIDI Channels you want. (See pp. 36-37 for instructions as to changing Tracks and MIDI Channels.)

The illustration below shows a typical configuration with the ESQ-M in MULTI Mode:

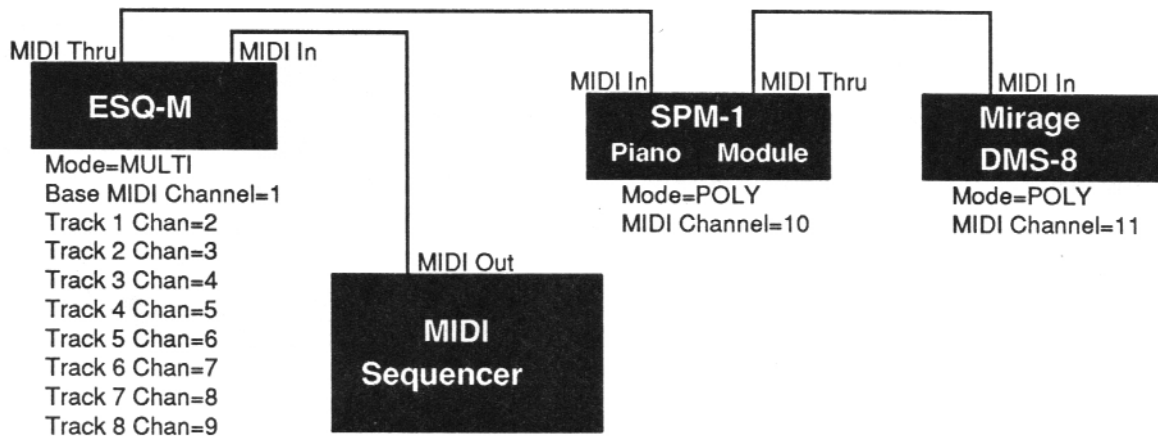

As you can see, the set-up is similar to the earlier POLY Mode example, except that now the ESQ-M is responding to nine MIDI Channels rather than one. The SPM-1 and the **Mirage** have been set to receive on MIDI Channels 10 and 11 respectively.

SOME IMPORTANT POINTS ABOUT MULTI MODE

- Each of the nine Tracks is completely independent and polyphonic. The **ESQ-M's** Dynamic Voice Assignment means that each Track can have up to all eight voices if it needs them. If all eight voices are in use and a Track needs a voice, it will "steal" the voice from the oldest note playing.
- In MULTI Mode Track 0 receives on the Base MIDI Channel. Each of the other eight Tracks will receive on the Channel it is set to. Each Track will respond independently to Controller and Program Changes on its MIDI Channel.
- The channel assignments shown in the illustration above are the default values. These are the Channels the nine Tracks are set to as the ESQ-M comes from the factory, or after its memory has been re-initialized. You may find it handy to use these channel assignments as is, or you can change any of these values. Any changes you make will be remembered.
- Only one Track can receive on a given MIDI Channel. If two (or more) Tracks are set to the same MIDI Channel, the lower-numbered Track will receive on that Channel and the higher-numbered Track(s) will not receive at all.
- You may not want all nine Tracks to receive. The sure way to "turn off" a Track is to set its MIDI Channel to the same number that is selected for the Base Channel (Track 0's Channel). Only Track 0 will ever receive on the Base Channel in MULTI Mode. Let's say you want only four Tracks — Tracks 0, 1, 2 and 3 — to play, and you want the other four Tracks not to receive

at all. Set the Tracks to receive as follows:

Track	MIDI Channel
0 (Base Channel)	1
1	2
2	3
3	4
4-8	1

The ESQ-M will respond only to information on MIDI Channels 1-4. Any information received on MIDI Channel 1 will be "intercepted" and played by Track 0. Tracks 4-8 will not respond to any MIDI data.

- When using a MIDI sequencer it's generally a good practice to assign a certain MIDI Channel (or channels) to each instrument in your rig and always leave it set to that Channel. You can avoid a lot of confusion if you know, for example, that the ESQ-M always responds to Channels 1 through 9, the **Mirage** always responds to Channel 10, the SPM-1 to Channel 11, etc.

USING THE ESQ-M WITH A MIDI GUITAR CONTROLLER

The ESQ-M is an ideal voice module to use with any MIDI Guitar Controller which is capable of sending in MONO Mode. MONO Mode (MIDI Mode 4) allows a guitar controller to send the notes played on each string on a different MIDI Channel. This has the advantage of letting each string send Pitch Bends independently, which is the only way to truly recreate guitar technique on a synthesizer.

Some earlier guitar synths do not support MONO mode. You will have to consult the manual of your particular model to see if it does. If you have a guitar synth which only sends in POLY Mode (i.e. sends all six strings on the same MIDI Channel) you should use the ESQ-M in POLY Mode (or OMNI Mode) and leave it on Track 0 when playing it from your guitar controller.

For MIDI Guitar Controllers which do support MONO Mode you should set up the ESQ-M and the guitar synth as follows:

- Select Track 1 on the ESQ-M
- On the MIDI Page, set the MODE parameter to **MODE=MONO**. This sets up Tracks 1-8 as independent, monophonic receivers. (Consult p.35 for a more complete description of MONO Mode.)
- Also on the MIDI Page, set the Base MIDI Channel to **BASECHAN=1**. Now Track 1 will receive on Channel 1, Track 2 will receive on Channel 2, Track 3 will receive on Channel 3, etc.
- Set your guitar controller to send in MONO Mode on Channels 1-6. (Some models have an easy shortcut for getting into this state.)
- Connect the MIDI Out of the guitar controller's converter to the MIDI In of the ESQ-M.

Now you're ready to play. The picture on the next page shows the optimal settings for both the ESQ-M and the guitar synth. You will notice that since the guitar has only six strings it only sends to six of the ESQ-M's Tracks. Tracks 7 and 8 won't be used in this set-up. They would, however, respond to MIDI information on MIDI Channel 7 or 8 if any were to come in. (When the eight-string MIDI Guitar Controller is developed, the ESQ-M is ready)

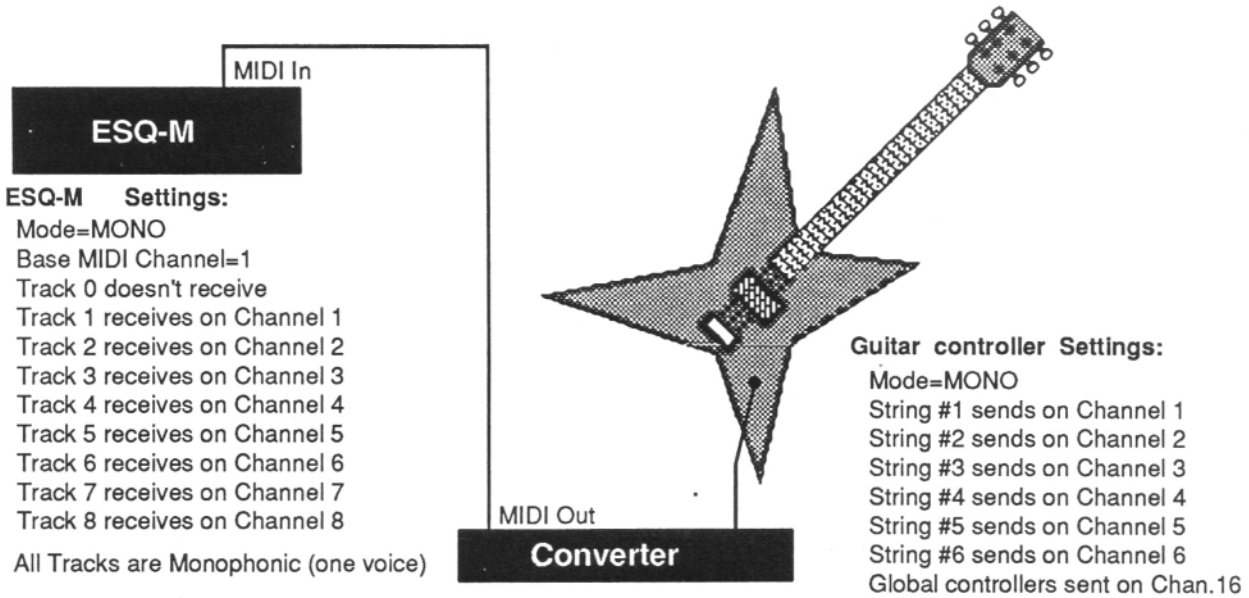

A few things to bear in mind:

- Notes played on each string will play only the corresponding Track. Each String/Track combination is totally independent.
- You can change the Program for each Track manually from the ESQ-M's front panel or by sending Program Changes from the controller via MIDI.
- Each Track will accept Program Changes independently. In many cases you will want to have the guitar controller send the same-numbered Program Change on all six channels so that all six strings play the same sound. You can, however, send the ESQ-M a different Program Change for each Track. You could use this effect to have, for example, a bass sound play on the bottom two strings and a piano sound on the top four. Or if you are feeling experimental you could play a different sound on each string.
- The Base Channel doesn't have to be set to Channel 1. It can be set to any channel from 1 to 9, and the channels for the Tracks will be adjusted accordingly (see p. 35). In most cases, though, setting things up as shown above will provide the most straight-forward and intuitive arrangement.
- The Base MIDI Channel can only be changed on the MIDI Page with Track 1 the current Track. When any other Track is selected the Display will show what MIDI Channel it is receiving on but the channel cannot be adjusted.

USING THE ESQ-M IN CONJUNCTION WITH AN ESQ-1

There are a number of ways in which the **ESQ-M** makes an excellent addition to the ENSONIQ ESQ-1 Digital Wave Synthesizer/Sequencer. You can use it with the **ESQ-1's** sequencer just as you would with any sequencer (as described earlier in this section). Or it can be used with the ESQ-1 in Overflow mode as a voice expander, so that the two units act like a single 16-voice instrument. Also you can program the ESQ-M remotely from an ESQ-1, as well as sending Programs or entire Program Banks between the machines via MIDI.

PROGRAMMING THE ESQ-M FROM AN ESQ-1: SYSTEM EXCLUSIVES

When the ESQ-M has been enabled to receive System Exclusive messages, you can select and modify nearly all its parameters remotely from an ESQ-1 simply by selecting and modifying the same parameter on the ESQ-1. The MIDI Out jack of the ESQ-1 must be connected to the MIDI In jack of the ESQ-M with a standard MIDI cable.

To enable the ESQ-M to receive System Exclusive messages:

- Press the **Param** button to put the ESQ-M in Parameter mode.
- Press the MIDI button on the Control Keypad to select the MIDI Page.
- Scroll to the MIDI ENABLE parameter (ENABL=_____) and set that parameter to **ENABL=KCPSYS** (Keys, Controllers, Program Changes and System Exclusive messages.)

The ESQ-M will now respond to the Data Entry Slider and the Up and Down Arrow buttons of the ESQ-1, as well as Parameter Selects, and the Compare button. When, for instance, you select the WAVE parameter on the **OSC1** Page of the ESQ-1, the same parameter will be selected on the ESQ-M. When you move the Data Entry Slider or press the Up and Down Arrow buttons you will see the value of the parameter change on the ESQ-M's Display.

All Program parameters, those saved with the individual Programs, can be selected and modified in this way. So can all the parameters on the **Master** Page. Note that while you can program the ESQ-M from an **ESQ-1**, once you have edited the Program you cannot remotely save (or Write) it into memory. That must be done from the ESQ-M's front panel, as described in Section 5.

Exceptions: There are a few ESQ-M parameters which cannot be adjusted remotely —specifically, all the parameters on the **ESQ-1's MIDI** Page. In other words you cannot change the **ESQ-M's** MIDI configuration via MIDI. You can select these parameters from the ESQ-1 (you will see them appear on the ESQ-M's Display) but you cannot change their values except from the ESQ-M's front panel.

NOTE: Be sure to return the setting of the MIDI Enables parameter to **ENABL=K+C+PC** when you are through programming and want to return to normal operation.

SEQUENCING THE ESQ-M FROM AN ESQ-1

When you use the ESQ-M in conjunction with the ESQ-1 and its sequencer, there are two ways you can go. The first is to proceed just as you would with any other sequencer, following the guidelines in the first part of this section. Treat the ESQ-M as on (or more) of the external instruments that you drive from the ESQ-1. For example:

- Put the ESQ-M in MULTI Mode (MIDI Page) and set the Tracks to the desired MIDI Channels as described earlier in "The ESQ-M as Nine Synthesizers."
 - On the ESQ-1, select a new Track in your sequence. On the **Mix/MIDI** Page, assign the Track MIDI Status, and then assign it to one of the MIDI Channels that the ESQ-M is receiving on.
 - Let's say that Track 1 on the ESQ-M is receiving on MIDI Channel 2. A Track of an ESQ-1 sequence assigned to send on Channel 2 will play Track 1 of the **ESQ-M**. If Track 2 on the ESQ-M is receiving on MIDI Channel 3, a Track of an ESQ-1 sequence assigned to send on Channel 3 will play it. And so on.
-

All you really need to do to use the two instruments in this way is to follow the instructions on recording Sequences in Section 6 of the ESQ-1 Musician's Manual, and treat each Track of the ESQ-M as a separate remote instrument.

MIDI OVERFLOW MODE: THE ESQ-M AS A VOICE EXPANDER FOR AN ESQ-1

The second way to use the ESQ-M with an ESQ-1 is to turn on the **ESQ-1's** Overflow Mode and let the ESQ-M play when the ESQ-1 runs out of voices. This has the advantage of allowing the two instruments to function as a single synthesizer with 16 dynamically assigned voices.

We highly recommend that the ESQ-1 be running Software Version 2.1 (or higher) if you will be using it in Overflow Mode with an ESQ-M. Version 2.1 contains a number of refinements added specifically to make this combination work better. The ESQ-1 tells you its Software Version each time you turn it on. If you have a Software Version below 2.1 you can contact your authorized ENSONIQ Repair Station for [details](#) about an update.

Overflow Mode on the ESQ-1 works like this:

- The first eight notes, whether played from the keyboard or by the sequencer, will play locally on the ESQ-1 and will not be sent out via MIDI.
- When all eight voices are in use, any notes the ESQ-1 is called upon to play will be sent out MIDI. It will not "steal" voices. Whenever a local voice is available, it will play the note. When one is not available the note will be sent out MIDI.
- The "Straight Synth" section of the ESQ-1 will overflow on the Base MIDI Channel (selected on the MIDI Page).
- Each sequencer Track which has LOCAL or BOTH status will overflow independently on its assigned MIDI Channel, selected on the **Tracks Mix/MIDI** Page. This is important to bear in mind because you must match up the Track MIDI Channels of the two instruments so that each LOCAL or BOTH Track of your ESQ-1 sequence overflows to a Track on the ESQ-M which is set to the same Channel. (The ESQ-M must be in MULTI Mode for this to work.)
- **ESQ-1** Tracks with BOTH status will behave the same as LOCAL Tracks when Overflow is on—they will send nothing over MIDI until all voices are busy, then will send everything over MIDI until a voice is again available. This means that with Overflow on you lose the ability to do what a BOTH Track normally does, which is to layer a local sound with a remote instrument. This is one of the trade-offs with Overflow Mode. When using Overflow mode it is best not to use BOTH status at all — Tracks with BOTH status will behave differently once you switch Overflow off, which could produce undesirable results.
- **ESQ-1** Tracks with LOCAL status will send Program Changes over MIDI when the Sequence is selected or comes around as a Song step (Ver. 2.1 or higher only). This allows the corresponding ESQ-M Track to always have the same Program.
- Both the "Straight Synth" and any LOCAL or BOTH Tracks on the **ESQ-1** will "echo" any incoming MIDI Program Changes they receive (Ver. 2.1 or higher only). This allows the ESQ-M to receive the same Program Change and thus have the right Programs on the Tracks which are receiving the overflow.
- **ESQ-1** Tracks with MIDI or SEQ status are not affected by Overflow Mode. They will behave as they usually do, sending all data out MIDI, not playing locally.

Setting Things Up

The first thing you need to do is to establish a standard for the relationship between the Tracks of the two units, and set each Track of the ESQ-M to the same MIDI Channel as the corresponding Track on the ESQ-1. The most logical and least confusing set-up is as follows:

ESQ-1.	Overflows to	ESQ-M	MIDI Channel
Straight Synth	---->	Track 0	1 (Base Channel)
Track 1	---->	Track 1	2
Track 2	---->	Track 2	3
Track 3	---->	Track 3	4
Track 4	---->	Track 4	5
Track 5	---->	Track 5	6
Track 6	---->	Track 6	7
Track 7	---->	Track 7	8
Track 8	---->	Track 8	9

To prepare the ESQ-M to receive Overflow from the ESQ-1 and its sequencer:

- Connect the MIDI Out of the ESQ-1 to the MIDI In of the ESQ-M with a standard MIDI cable.
- Put the ESQ-M in MULTI Mode (MIDI Page.)
- For each Track of the ESQ-M, set the MIDI Channel as shown above. (Or you can select a different set of Channels, but you must remember to assign the same channels to the corresponding ESQ-1 Tracks and the "Straight Synth.") See pp. 36-37 for information on Track MIDI Channels.
- The ESQ-M must have the same Programs in its Internal Memory as the ESQ-1. You can easily send the **ESQ-1's** Internal Program Bank to the ESQ-M via MIDI (see Section 3 of the ESQ-1 Musician's Manual for details). And if cartridge sounds are used the ESQ-M must have the identical cartridge inserted. (For this reason it is recommended that all sounds in the sequence be Internal sounds. Transfer sounds from the cartridge to the Internal Memory if necessary)

On the ESQ-1:

- Set the Base Channel (on the MIDI Page) to Channel 1. (Or any other Channel you prefer, but it should be the same Channel assigned to Track 0 on the ESQ-M.)
- Whenever you define a new LOCAL Track of a sequence, go the **Mix/MIDI** Page and set its MIDI Channel according to the table above. That will allow it to overflow notes to, and send the proper Program Change and Mix level to, the corresponding ESQ-M Track.
- On the ESQ-1, turn Overflow Mode On (OVFL=ON on the MIDI Page). Do not turn On the ESQ-M's Overflow Mode.

The rest will take care of itself. Whenever the "Straight Synth" or one of the LOCAL (or BOTH) Tracks of an ESQ-1 sequence runs out of voices, it will send the note out via MIDI on its designated Channel, and the note will be played by corresponding Track of the **ESQ-M**.

Try This

Once things are set up, make sure the **ESQ-1's** Overflow Mode is on and then try this. Select a "Straight Synth" sound in the usual way on the **ESQ-1**. If you have your Channel assignments right this should send a Program Change to Track 0 of the ESQ-M, assuring that it has the same sound. Now turn the **ESQ-1's** volume down, and the ESQ-M's volume up. Play eight notes, and hold them down. You shouldn't hear anything from the ESQ-M. Now play a ninth note. That note and subsequent ones should sound on the ESQ-M, until you release some keys and the ESQ-1 again has voices available.

Now turn the **ESQ-1's** volume back up, matching as closely as possible the levels of the two instruments. It is very important that the volume, EQ and effects settings of the ESQ-M and the ESQ-1 at your mixer or amp be the same — remember, they are acting together as a single unit, and any major differences in their sound settings will spoil the effect.

Als
o,
if you are operating the ESQ-M and the ESQ-1 in stereo you should be sure to Pan the right outputs of both instruments right, and the left outputs of both instruments left, to avoid differences in the pan locations between the two instruments.

Adapting Existing ESQ-1 Sequences for Overflow

If you want to use Overflow Mode with ESQ-1 sequences that you had previously created without Overflow, you must do the following:

- In each sequence, for each Track with LOCAL Status, go to the **Mix/MIDI** Page and assign it the proper MIDI Channel according to the table shown above. (Or assign it a Channel based on whatever alternative scheme you have decided on. But above all, be consistent. Always use the same MIDI Channel for the same Track on both instruments.)
- As mentioned earlier, Tracks with BOTH status will act like LOCAL Tracks with Overflow on. If you have BOTH Tracks in your sequence, you will have to decide whether you want to 1) leave them that way and have them play only on the **ESQ's**, or 2) change the status to MIDI, so that they will play only on the remote instrument(s).
- If there are MIDI only Tracks in your sequence which are playing remote instruments, they will behave just as they always did. But check to see none of them is set to the a MIDI Channel that is being used for Overflow. If they are, change the MIDI Channel of one or the other.

Overflow Mode and two ESQ-M's

Two ESQ-M's can be made to act as a single 16-voice instrument by turning on Overflow on the first unit. The concept is basically the same as described above. You will need to do the following:

- Connect the MIDI Out of your master controller to the MIDI In of the first ESQ-M.
- Connect the MIDI Out (not the Thru) of the first ESQ-M to the MIDI In of the second **ESQ-M**.
- Put both units in MULTI Mode (for use with a sequencer or other poly-timbral application) or POLY Mode (for using one sound at a time). In either case, both units should be in the same MIDI Mode.
- Each Track on the second ESQ-M should be set to the same MIDI Channel as the same track on the first ESQ-M. For example (in MULTI Mode):

<u>ESO-M #1</u>	<u>Overflows to</u>	<u>ESO-M #2</u>	<u>MIDI Channel</u>
Track 0		Track 0	1 (Base Channel)
Track 1		Track 1	2
Track 2		Track 2	3
Track 3		Track 3	4
Track 4		Track 4	5
Track 5		Track 5	6
Track 6		Track 6	7
Track 7		Track 7	8
Track 8		Track 8	9

Again these are recommendations. You can use any channel assignments you want as long as they are the same for both units.

- Turn On MIDI Overflow Mode on the first ESO-M only. (See p. 32) Now when the first ESQ-M runs out of voices it will send the overflow to the second ESQ-M instead of stealing voices.

Section 7 — Appendices

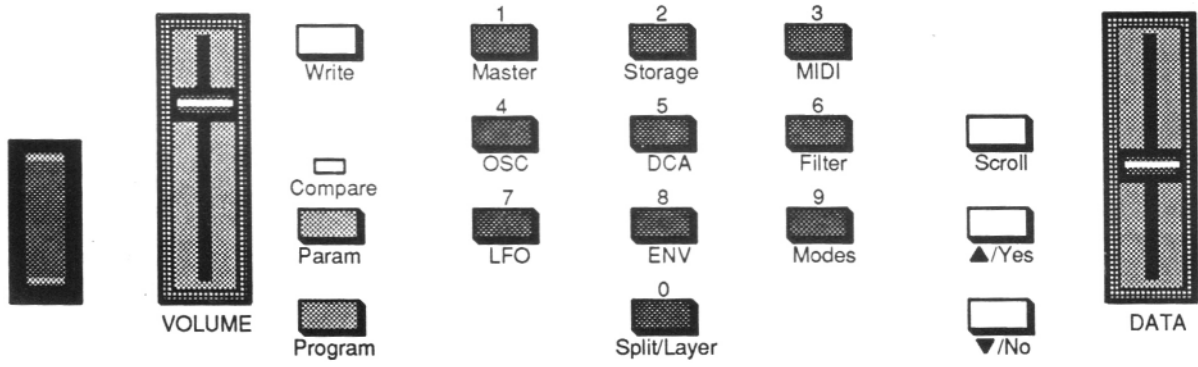

ABOUT THE PROGRAM SHEET

The Program Sheet on the following Page can be used to transcribe the parameters of ESQ sounds you create. This is an effective way to trade sounds with people in other areas. Also, writing out a sound in this way can sometimes help you to understand why a Program sounds like it does, by letting you see all the parameter settings at a glance.

Feel free to photocopy this form and use the copies to document your ESQ-M sounds.

ESQ-1 TO ESQ-M PARAMETER REFERENCE

Each Program parameter on the ESQ-M has an exact counterpart on the ESQ-1. All ESQ-1 and ESQ-M Programs and parameters are fully compatible with each other. However, because the ESQ-M has a fundamentally different user interface, some of the parameter names appear slightly different from the same parameter on the ESQ-1.

It is our desire to promote one standard for all ESQ parameter listings in order to avoid confusion when people exchange sounds in this form. So the Program Sheet on the opposite page is the same one that appears in the ESQ-1 Musician's Manual — it refers to parameter names as they appear on the ESQ-1. In most cases it will be obvious to you which parameter name on the Program Sheet corresponds to which ESQ-M parameter. But in a few cases you may not be sure. For this reason the table below has been provided as a reference to help you in using the Program Sheet to transcribe your own sounds or to program sounds which you have obtained in parameter sheet form..

PAGE:	Prop Sheet/ESQ-1:	ESQ-M Param:	PAGE	prop Sheet/ESQ-1:	ESQ-M Param:
OSC (1-3):	OCT	OCTAVE	LFO (1-3):	WAV	WAVE
	SEMI	SEMITONE		L1	LEVEL 1
	FINE	FINETUNE		DELAY	DELAY
	WAVE	WAVE		L2	LEVEL 2
	MOD#1	MOD1	MOD	MOD	
	DEPTH	MODAMTI	ENV (1-4):	Li	LEVEL 1
	MOD#2	MOD2		L2	LEVEL 2
DEPTH	MODAMT2	L3		LEVEL 3	
		LV		VEL LVL	
DCA (1-3):	LEVEL	LEVEL	T1 V	VEL T1	
	OUTPUT	OUTPUT	T1	TIME 1	
	MOD# 1	MOD1	T2	TIME 2	
	DEPTH	MODAMT1	T3	TIME 3	
	MOD#2	MOD2	T4	TIME 4	
	DEPTH	MODAMT2	TK	KBD SCAL	
FILT:	FREQ	CT FREQ	MODES:	SYNC	SYNC
	Q	RES (Q)		AM	AM
	KEYBD	KBD TRAC		MONO	MONO
	MOD#1	MOD1		GLIDE	GLIDE
	DEPTH	MODAMTI		VC	RST VC
	MOD#2	MOD2		ENV	RST ENV
DCA 4:	Final Vol (ENV4)	ENV4 MOD	OSC	RST OSC	
	PAN	PAN LOC	CYC	ENV CYC	
	PAN MODULATOR	PNMOD	Split/Layer	SPLIT/LAYER	SP/LA (sw)
	DEPTH	PMODAMT		SPLIT/LAYER Program	SP/LA (prog)
		LAYER		LAYER (sw)	
		LAYER Program		LAYER (prog)	
LFO (1-3):	FREQ	FREQ	SPLIT	SPLIT (sw)	
	RESET	RESET	SPLIT Program	SPLIT (prog)	
	HUMAN	HUMAN	SPLITKEY	SPLITKEY	



PROGRAM SHEET

PROGRAM:

	OCT=	SEMI=	FINE =	WAVE=	MOD#1	DEPTH	MOD#2	--> DEPTH
OSC 1								-
OSC 2								
OSC 3								

	LEVEL=	OUTPUT=	MOD#1	DEPTH	MOD#2	DEPTH
DCA 1		On Off				
DCA 2		On Off				
DCA 3		On Off				

	FREQ=	Q=	KEYBD=	MOD#1	DEPTH	MOD#2	I DEPTH
I Filter							

	Fin& Vol.(ENV 4))	PAN=	PAN	DEPTH
DCA 4				

	FREQ=	RESET=			L1=	DELAY=	L2=	
LFO 1		On Off	On Off					
LFO 2		On Off	On Off					
LEO 3		On Off	On Off					

	L1=	L2=	L3=	LV=	T1V=	TI=	T2=	T3=	T4=	TK=
ENV 1										
ENV 2										
ENV 3										
ENV 4										

	SYNC=	AM=	MONO=	GLIDE=	VC=	ENV=	OSC=	CYC=
Modes	On Off	On Off	On Off		On Off	On Off	On Off	On Off

Split/Layer Split/Layer Layer Layer Split Split Split
 Split/Layer= Program Program Program Program Program Key=
 On Off On Off On Off On Off On Off On Off

PCB Structure, Part One

Envelopes

Four sets of envelope variables

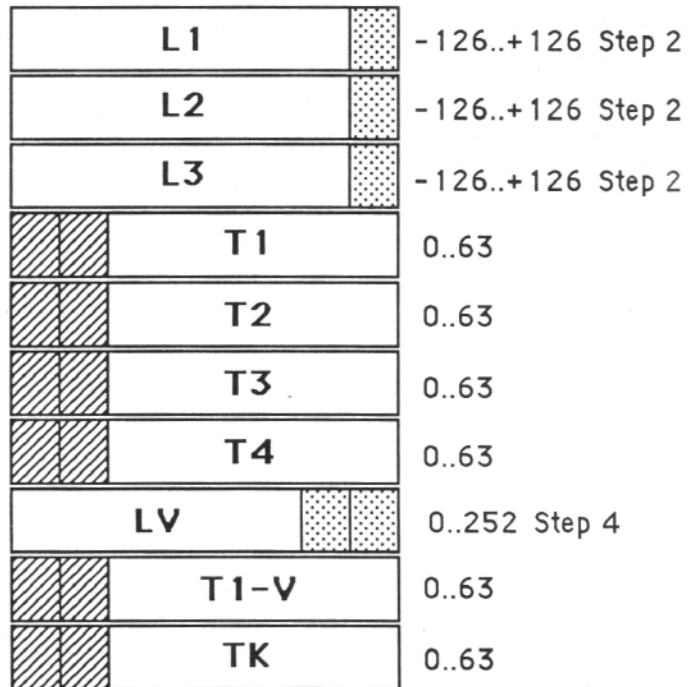

Low Frequency Oscillators

Three sets of LFO variables

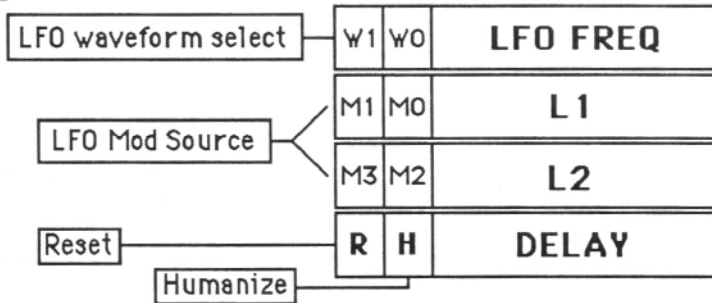

Oscillators

Three sets of OSC variables

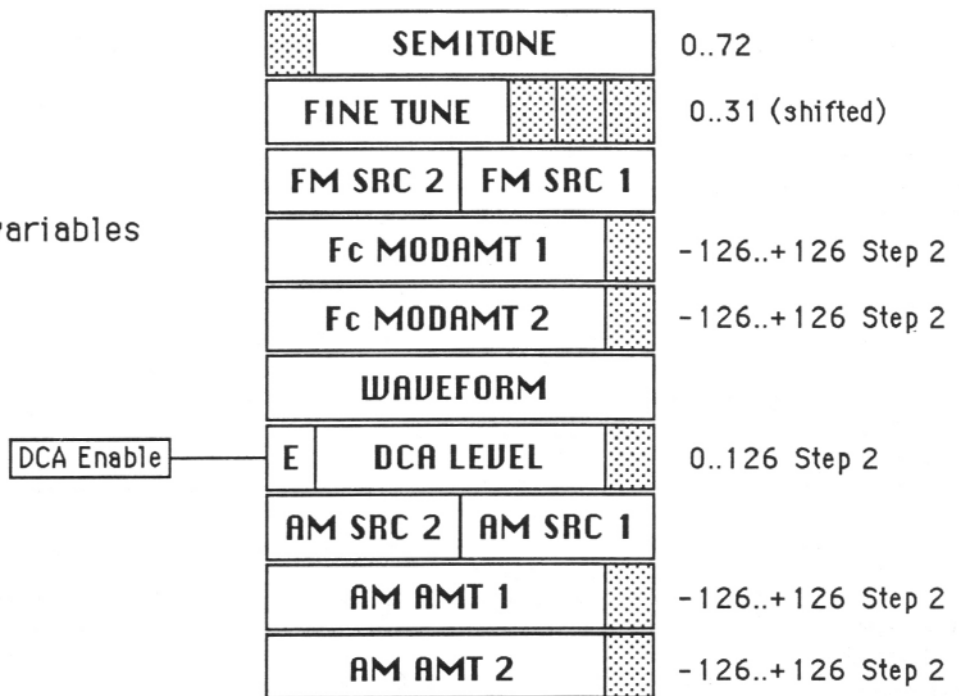

PCB Structure, Part Two

Miscellaneous

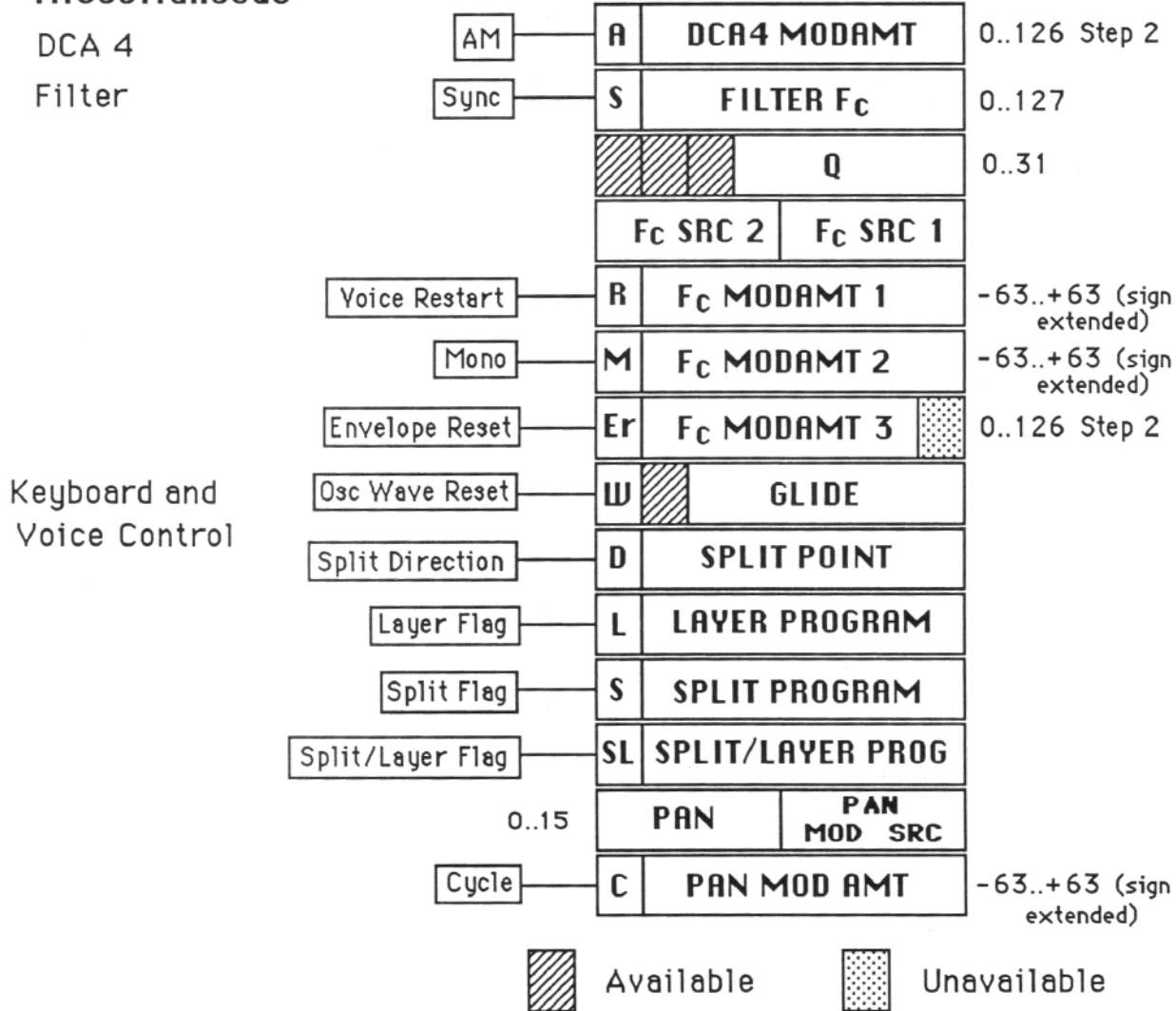

Complete PCB Structure

102 Bytes Total

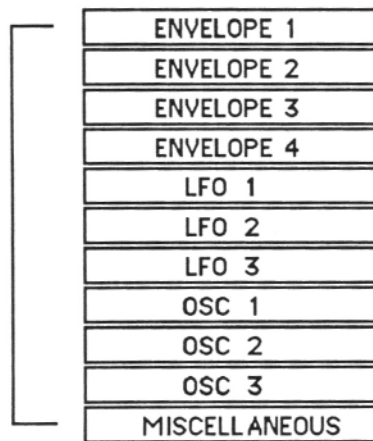

*Page
Intentionally
Left Blank*



a
t

e: 3/16/87 M O D E L : E S Q - M
Implementation Chart

Version: 1.0

MIDI

Function...	Transmitted	Recognized	Remarks
Basic Channel Default Channel	1 1- 16	1 1- 16	
Mode Default Messages Altered		1, 3, 4, Multi	memorized
Note Number True Voice	21 - 108	21 - 108	
Velocity Note ON Note OFF	0 *	0 0	
After Touch Key's Ch's	0*	0 0	
Pitch Bender	0	0	
Control Change	1 - 95 1 Mod Wheel 2 Breath 4 Foot 6 Data 7 Volume 96 Inc 97 Dec 98 Param 99 Param	1 - 95 1 Mod Wheel 2 Breath 4 Foot 6 Data 7 Volume 96 Inc 97 Dec 98 Param 99 Param	programmable
Prog Change True #	0 - 119	0 - 119	
System Exclusive	0	0	
System Common : Song Pos : Song Sel : Tune	X X X	X X X	
System Real Time : Clock : Commands	X X	X X	
Aux Mes- sages : Local On/Off : All Notes Off : Active Sense : Reset	X X X X	X X X X	
Notes	* Transmitted in Overflow Mode only		

Mode 1: OMNI ON, POLY
Mode 3: OMNI OFF, POLY

Mode 2: OMNI ON, MONO
Mode 4: OMNI OFF MONO

: YES
X : NO

1.0 ESQ-M System Exclusive Format

1.1 ESQ-M System Exclusive Header

All ESQ-M System Exclusive messages start with the following header. The receiving ESQ-M will only recognize system exclusive messages if the MIDI channel number in the message is the same as the MIDI base channel selected on its MIDI page and its MIDI enable parameter is set to recognize system exclusive messages (i.e. the display should show ENABL=KCPSYS).

11110000	System Exclusive status byte
00001111	ENSONIQ I.D. code
00000010	ESQ Product I.D. code
0000nnnn	MIDI channel number

1.2 Program Dumps

To be able to receive this data, the ESQ-M must be in program select mode (i.e. the program page must be displayed) and the MIDI enable parameter on the MIDI page must be set to receive system exclusive messages.

1.2.1 Single Program Dump

This transmits the program currently selected on the current Track. Refer to Table 1 for details on the structure of the program.

xxxxxxx	ESQ System Exclusive header
00000001	Single Program Dump code
00001111	2 nybbles per byte of program data
0000nnnn	102 data bytes (204 nybble-ized MIDI bytes) 1= low nybble, h = high nybble
11110111	End of exclusive <u>1.2.2</u>

All Program Dump

This message transmits the 40 internal programs.

xxxxxxx	ESQ System Exclusive header
00000010	All Program Dump code
00001111	2 nybbles per byte of program data
0000nnnn	102 * 40 data bytes (9160 nybble-ized MIDI bytes) 1= low nybble, h = high nybble
11110111	End of exclusive

1.3 Received Virtual Keypad Events

This system exclusive message allows an external device to simulate the pressing of the ESQ-M's front panel buttons. The format of the message is an ESQ System Exclusive Header, followed by the Keypad Command Code, and then a stream of button down and button up codes which is terminated by an End of Exclusive.

NOTE: Each Button Down keypad event should be followed by a Button Up event for the same button to prevent the inbound keypad event processor from becoming "hung up" while waiting for a button to be released. This should usually be done within one system exclusive message. It should also be possible to follow up with separate messages, but be careful not to leave dangling button downs !

```

xxxxxxx      ESQ System Exclusive header
00001111     Keypad Command code (Data
              stream...)

Onnnnnnn     Any number of keypad events (button down/up codes) One
              button down or button up event per byte. (button codes
              are specified in the table below)

11110111     End of exclusive
    
```

		B u t t o n C o d e s		
		Down	Up	
Dec.	Hex	Hex	Hex	Front Panel Button Name
00	00	16	10	0 (Split/Layer)
01	01	17	11	1 (Master)
02	02	18	12	2 (Storage)
03	03	19	13	3 (MIDI)
04	04	20	14	4 (OSC)
05	05	21	15	5 (DCA)
06	06	22	16	6 (Filter)
07	07	23	17	7 (LFO)
08	08	24	18	8 (ENV)
09	09	25	19	9 (Modes)
10	0A	26	1A	Up Arrow/Yes
11	0B	27	1B	Down Arrow/No
12	0C	28	1C	Scroll
13	0D	29	1D	Program
14	0E	30	1E	Param
15	0F	31	1F	Write

As you may have observed, the button up codes are differentiated from the button down codes by a positive offset of 16 decimal or \$10 hex. Unlike the ESQ-1 the Button Code 00 is a legal key event within the system. Also, button codes out of the range specified in the above table should not be sent to the ESQ-M.

1.4 Compare Button Status Message

This message is both sent and received by the ESQ-M. It is sent whenever the Compare status of the ESQ-M is changed by pressing the Param/Compare button. The same message format is recognized when it is received from another ESQ product if recognition of system exclusive messages is enabled (MIDI ENABL=KCPSYS).

xxxxxxxx	ESQ System Exclusive header
00010000	Compare Status Command code
0000000n	Status of the Compare button n=1, Compare On n=0, Compare Off
11110111	End of exclusive

1.5 Device Inquiry Message

The ESQ-M supports the MIDI Device Inquiry message which allows instruments and computers to ascertain the identity of the unit(s) to which they are connected. The ESQ-M will respond to the following Device Inquiry Message with the Device ID Message detailed below. The ESQ-M will respond to the inquiry if the channel information in the message contains either the base MIDI channel number of the ESQ-M or the all channel broadcast code (\$7F).

11110000	System Exclusive status byte
01111110	Non real time message
0000nnnn	nnnn=MIDI Channel number or
01111111	All channel broadcast code
00000110	General Information message code
00000001	Device Inquiry Message message code
11111110	End of Exclusive

1.6 Device ID Message

When the ESQ-M receives a correctly formatted MIDI Device Inquiry message it will respond with the following Device ID Message. This message follows the MMA recommendations for device ID messages, and contains information about the responding device including manufacturer, product family and software revision.

11110000	System Exclusive Status byte
01111110	Non real time message
0000nnnn	nnnn=Base MIDI Channel
00000110	General Information message code
00000010	Device ID Message code
00001111	ENSONIQ System Exclusive manufacturer's code
00000010	ESQ Product Family code (lsb)
00000000	ESQ Product Family code (msb)
00000010	ESQ-M Family Member code (lsb)
00000000	ESQ-M Family Member code (msb)
00000000	Software revision information 00000000
0nnnnnnn	Major Version number (integer portion)
0nnnnnnn	Minor version number (decimal fraction)
11111110	End of Exclusive

ESQ-M MIDI Parameter Number List

The numbers below are the numbers that are 'sent in the Parameter Select controllers (MIDI Controller #'s 98 and 99). Note that the **ESQ-M** will recognize MIDI Parameter Selects only if System Exclusive messages are enabled (ENABL=KPCSYS on the MIDI Page.)

Page	Param #		Parameter
	dec	hex	
ENV1	0	00	ENV1 L1 parameter
	1	01	ENV1 L2 parameter
	2	02	ENV1 L3 parameter
	3	03	ENV1 LV parameter
	4	04	ENV1 TIV parameter
	5	05	ENV1 TI parameter
	6	06	ENV1 T2 parameter
	7	07	ENV1 T3 parameter
	8	08	ENV1 T4 parameter
	9	09	ENV1 TK parameter

ESQ-M – Musician's Manual

Page

Param #

	dec	hex	
ENV2			
	10	0A	ENV2 L1 parameter
	11	0B	ENV2 L2 parameter
	12	0C	ENV2 L3 parameter
	13	0D	ENV2 LV parameter
	14	0E	ENV2 T1V parameter
	15	0F	ENV2 T1 parameter
	16	10	ENV2 T2 parameter
	17	11	ENV2 T3 parameter
	18	12	ENV2 T4 parameter
	19	13	ENV2 TK parameter
ENV3			
	20	14	ENV3 L1 parameter
	21	15	ENV3 L2 parameter
	22	16	ENV3 L3 parameter
	23	17	ENV3 LV parameter
	24	18	ENV3 T1V parameter
	25	19	ENV3 T1 parameter
	26	1A	ENV3 T2 parameter
	27	1B	ENV3 T3 parameter
	28	1C	ENV3 T4 parameter
	29	1D	ENV3 TK parameter
ENV4			
	30	1E	ENV4 L1 parameter
	31	1F	ENV4 L2 parameter
	32	20	ENV4 L3 parameter
	33	21	ENV4 LV parameter
	34	22	ENV4 T1V parameter
	35	23	ENV4 T1 parameter
	36	24	ENV4 T2 parameter
	37	25	ENV4 T3 parameter
	38	26	ENV4 T4 parameter
	39	27	ENV4 TK parameter
LFO1			
	40	28	LFO1 frequency parameter
	41	29	LFO1 reset parameter
	42	2A	LFO1 humanize switch parameter
	43	2B	LFO1 modulation waveform parameter
	44	2C	LFO1 L1 parameter
	45	2D	LFO1 delay parameter
	46	2E	LFO1 L2 parameter
	47	2F	LFO1 modulation source parameter
LFO2			
	48	30	LFO2 frequency parameter
	49	31	LFO2 reset parameter
	50	32	LFO2 humanize switch parameter
	51	33	LFO2 modulation waveform parameter
	52	34	LFO2 L1 parameter
	53	35	LFO2 delay parameter
	54	36	LFO2 L2 parameter
	55	37	LFO2 modulation source parameter

Page	Param #		Parameter
	dec	hex	
LFO3	56	38	LFO3 frequency parameter
	57	39	LFO3 reset parameter
	58	3A	LFO3 humanize switch parameter
	59	3B	LFO3 modulation waveform parameter
	60	3C	LFO3 L1 parameter
	61	3D	LFO3 delay parameter
	62	3E	LFO3 L2 parameter
	63	3F	LFO3 modulation source parameter
OSC1 64		40	OSC1 octave parameter
	65	41	OSC1 semitone parameter
	66	42	OSC1 finetune parameter
	67	43	OSC1 waveform parameter
	68	44	OSC1 modulation source 1 parameter
	69	45	OSC1 modulation amount 1 parameter
	70	46	OSC1 modulation source 2 parameter
	71	47	OSC1 modulation amount 2 parameter
OSC2	72	48	OSC2 octave parameter
	73	49	OSC2 semitone parameter
	74	4A	OSC2 finetune parameter
	75	4B	OSC2 waveform parameter
	76	4C	OSC2 modulation source 1 parameter
	77	4D	OSC2 modulation amount 1 parameter
	78	4E	OSC2 modulation source 2 parameter
	79	4F	OSC2 modulation amount 2 parameter
OSC3	80	50	OSC3 octave parameter
	81	51	OSC3 semitone parameter
	82	52	OSC3 finetune parameter
	83	53	OSC3 waveform parameter
	84	54	OSC3 modulation source 1 parameter
	85	55	OSC3 modulation amount 1 parameter
	86	56	OSC3 modulation source 2 parameter
	87	57	OSC3 modulation amount 2 parameter
DCA1	88	58	DCA1 level parameter
	89	59	DCA1 output enable parameter
	90	5A	DCA1 modulation source 1 parameter
	91	5B	DCA1 modulation amount 1 parameter
	92	5C	DCA1 modulation source 2 parameter
	93	5D	DCA1 modulation amount 2 parameter
DCA2	94	5E	DCA2 level parameter
	95	5F	DCA2 output enable parameter
	96	60	DCA2 modulation source 1 parameter
	97	61	DCA2 modulation amount 1 parameter
	98	62	DCA2 modulation source 2 parameter
	99	63	DCA2 modulation amount 2 parameter

ESQ-M – Musician's Manual

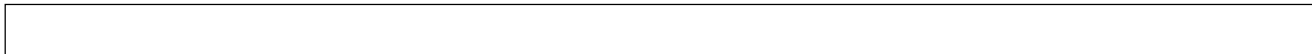

<u>Page</u>	<u>Param # dec</u> <u>hex</u>	<u>Parameter</u>
DCA3		
	100 64	DCA3 level parameter
	101 65	DCA3 output enable parameter
	102 66	DCA3 modulation source 1 parameter
	103 67	DCA3 modulation amount 1 parameter
	104 68	DCA3 modulation source 2 parameter
	105 69	DCA3 modulation amount 2 parameter
DCA4		
	106 6A	DCA4 modamt parameter
	107 6B	PAN position parameter
	108 6C	PAN modulation source parameter PAN
	109 6D	modulation amount parameter
FILTER		
	110 6E	FILTER ER Fc (cutoff) parameter
	111 6F	FILTER Q (resonance) parameter
	112 70	FILTER modulation amount 3 parameter
	113 71	FILTER modulation source 1 parameter
	114 72	FILTER modulation amount 1 parameter
	115 73	FILTER modulation source 2 parameter
	116 74	FILTER modulation amount 2 parameter
MODES		
	117 75	MODES AM switch parameter
	118 76	MODES glide parameter
	119 77	MODES mono switch parameter
	120 78	MODES sync switch parameter
	121 79	MODES voice reassign switch parameter
	122 7A	MODES envelope reset switch parameter
	123 7B	MODES wave reset switch parameter
	124 7C	MODES cycle switch parameter
SPLIT/LAYER		
	125 7D	S/L split layer switch parameter
	126 7E	S/L split layer program parameter
	127 7F	S/L layer switch parameter
	128 80	S/L layer program parameter
	129 81	S/L split direction parameter
	130 82	S/L split program parameter
	131 83	S/L split point parameter

* the following parameter numbers (132-143) are used for the non-pcb system parameters

System parameters:

MASTER		MASTER tuning parameter
132	84	MASTER velocity parameter MASTER pedal switch parameter MASTER pitch bend range parameter
133	85	MASTER pitch bend mode parameter
134	86	
135	87	
136	88	

Page	<u>Param #</u>		<u>Parameter</u>
	dec	hex	
MIDI	137	89	MIDI base channel parameter
		138 8A	MIDI overflow switch parameter
		139 8B	MIDI xcontrol parameter MIDI
		140 8C	pressure parameter MIDI mode
		141 8D	parameter MIDI enable parameter
	142 8E		

* The parameters on the MIDI Page (137-142) can be selected but not modified via MIDI.

ESQ-M SPECIFICATIONS

CONTROLLER RESPONSE FEATURES

- Responds to polyphonic velocity and pressure sensitivity
- Programmable split point
- Sound layering
- Polyphonic glide, fingered mono glide

VOICE ARCHITECTURE

- 8-voice polytimbral
- 3 digital waveform oscillators per voice
- Amplitude modulation on each oscillator
- 32 multi-sampled and synthetic waveforms
- 15 routable voice modulation sources
- 3 multi-waveform LFO's per voice with humanized random variation
- 4 complex envelope generators per voice, velocity controlled
- Programmable panning and level
- Hard sync and ring modulation (AM)
- Analog filters, 4-pole low-pass with variable resonance

PROGRAM PARAMETERS

- 16-character fluorescent display, readable in all lighting conditions
- 40 internal programs, direct access
- 80 external cartridge programs, direct access with cartridge installed
- Compare mode for comparing programs

MIDI

- Poly, Omni, Multi and Mono modes
- "MIDI Overflow Mode" permits slaving other ESQ-M's for 16 or more voices (each ESQ-M adds 8 voices)

- 9 simultaneous polyphonic channels with separate programs
- Global controllers in mono mode for use with MIDI guitar controllers, etc.
- MIDI standard remote programming

INPUTS/OUTPUTS

- Left/Mono and Right channel audio outputs allow voices to be panned.
- Pedal/Control Voltage Input (allows modulation of voices from an external source)
- MIDI In, MIDI Out, MIDI Thru

STANDARD ACCESSORIES

- Standard accessories include: Owner's/Programming Guide, detachable power cord, rack-mount hardware

OPTIONAL ACCESSORIES

- ENSONIQ E-EPROM Cartridge - for storing up to 80 player-created programs
- CV pedal - for voice modulation and volume control

DIMENSIONS

- 17 1/4" (44cm) wide (19" with rack hardware installed) x 3 1/2" (9cm) high x 12" (30cm) deep
- Weight: 13 pounds (5.7 kilograms)

WARRANTY

One year, parts and labor
Refer to Warranty card enclosed

Specifications subject to change without notice.

\$3.95
MM-11
931-000-1301

ensoniq[®]