

# MUSIC ATELIER

## AT20R

### Owner's Manual

Before using this unit, carefully read the sections entitled: "IMPORTANT SAFETY INSTRUCTIONS" (p. 2), "USING THE UNIT SAFELY" (p. 3), and "IMPORTANT NOTES" (p. 4, 5). These sections provide important information concerning the proper operation of the unit. Additionally, in order to feel assured that you have gained a good grasp of every feature provided by your new unit, Owner's manual should be read in its entirety. The manual should be saved and kept on hand as a convenient reference.

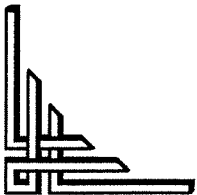

Copyright © 1999 ROLAND CORPORATION

All rights reserved. No part of this publication may be reproduced in any form without

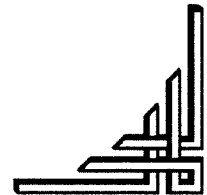

Roland®



	<b>CAUTION</b> RISK OF ELECTRIC SHOCK DO NOT OPEN	
<b>ATTENTION:</b> RISQUE DE CHOC ELECTRIQUE NE PAS OUVRIR		
<b>CAUTION:</b> TO REDUCE THE RISK OF ELECTRIC SHOCK, DO NOT REMOVE COVER (OR BACK). NO USER-SERVICEABLE PARTS INSIDE. REFER SERVICING TO QUALIFIED SERVICE PERSONNEL.		



The lightning flash with arrowhead symbol, within an equilateral triangle, is intended to alert the user to the presence of uninsulated "dangerous voltage" within the product's enclosure that may be of sufficient magnitude to constitute a risk of electric shock to persons.



The exclamation point within an equilateral triangle is intended to alert the user to the presence of important operating and maintenance (servicing) instructions in the literature accompanying the product.

INSTRUCTIONS PERTAINING TO A RISK OF FIRE, ELECTRIC SHOCK, OR INJURY TO PERSONS.

## IMPORTANT SAFETY INSTRUCTIONS

### SAVE THESE INSTRUCTIONS

**WARNING** - When using electric products, basic precautions should always be followed, including the following:

1. Read all the instructions before using the product.
2. Do not use this product near water — for example, near a bathtub, washbowl, kitchen sink, in a wet basement, or near a swimming pool, or the like.
3. This product should be used only with a cart or stand that is recommended by the manufacturer.
4. This product, either alone or in combination with an amplifier and headphones or speakers, may be capable of producing sound levels that could cause permanent hearing loss. Do not operate for a long period of time at a high volume level or at a level that is uncomfortable. If you experience any hearing loss or ringing in the ears, you should consult an audiologist.
5. The product should be located so that its location or position does not interfere with its proper ventilation.
6. The product should be located away from heat sources such as radiators, heat registers, or other products that produce heat.
7. The product should be connected to a power supply only of the type described in the operating instructions or as marked on the product.
8. The power-supply cord of the product should be unplugged from the outlet when left unused for a long period of time.
9. Care should be taken so that objects do not fall and liquids are not spilled into the enclosure through openings.
10. The product should be serviced by qualified service personnel when:
  - A. The power-supply cord or the plug has been damaged; or
  - B. Objects have fallen, or liquid has been spilled into the product; or
  - C. The product has been exposed to rain; or
  - D. The product does not appear to operate normally or exhibits a marked change in performance; or
  - E. The product has been dropped, or the enclosure damaged.
11. Do not attempt to service the product beyond that described in the user-maintenance instructions. All other servicing should be referred to qualified service personnel.

**For the USA**

This product may be equipped with a polarized line plug (one blade wider than the other) . This is a safety feature. If you are unable to insert the plug into the outlet, contact an electrician to replace your obsolete outlet. Do not defeat the safety purpose of the plug.

**For Canada**

For Polarized Line Plug

**CAUTION:** TO PREVENT ELECTRIC SHOCK, MATCH WIDE BLADE OF PLUG TO WIDE SLOT, FULLY INSERT.

**ATTENTION:** POUR ÉVITER LES CHOCs ÉLECTRIQUES, INTRODUIRE LA LAME LA PLUS LARGE DE LA FICHE DANS LA BORNE CORRESPONDANTE DE LA PRISE ET POUSSER JUSQU' AU FOND.

**For the U.K.**

**IMPORTANT:** THE WIRES IN THIS MAINS LEAD ARE COLOURED IN ACCORDANCE WITH THE FOLLOWING CODE.

BLUE: NEUTRAL  
BROWN: LIVE

As the colours of the wires in the mains lead of this apparatus may not correspond with the coloured markings identifying the terminals in your plug, proceed as follows:  
 The wire which is coloured BLUE must be connected to the terminal which is marked with the letter N or coloured BLACK.  
 The wire which is coloured BROWN must be connected to the terminal which is marked with the letter L or coloured RED.  
 Under no circumstances must either of the above wires be connected to the earth terminal of a three pin plug.

# USING THE UNIT SAFELY

## INSTRUCTIONS FOR THE PREVENTION OF FIRE, ELECTRIC SHOCK, OR INJURY TO PERSONS

### About ⚠ WARNING and ⚠ CAUTION Notices

<b>⚠ WARNING</b>	Used for instructions intended to alert the user to the risk of death or severe injury should the unit be used improperly.
<b>⚠ CAUTION</b>	Used for instructions intended to alert the user to the risk of injury or material damage should the unit be used improperly. * Material damage refers to damage or other adverse effects caused with respect to the home and all its furnishings, as well to domestic animals or pets.

### About the Symbols

	The ⚠ symbol alerts the user to important instructions or warnings. The specific meaning of the symbol is determined by the design contained within the triangle. In the case of the symbol at left, it is used for general cautions, warnings, or alerts to danger.
	The ⚡ symbol alerts the user to items that must never be carried out (are forbidden). The specific thing that must not be done is indicated by the design contained within the circle. In the case of the symbol at left, it means that the unit must never be disassembled.
	The ⚡ symbol alerts the user to things that must be carried out. The specific thing that must be done is indicated by the design contained within the circle. In the case of the symbol at left, it means that the power-plug must be unplugged from the outlet.

### ALWAYS OBSERVE THE FOLLOWING

#### ⚠ WARNING

- Before using this unit, make sure to read the instructions below, and the Owner's Manual.
- Do not open or perform any internal modifications on the unit.
- Make sure you always have the unit placed so it is level and sure to remain stable. Never place it on stands that could wobble, or on inclined surfaces.
- Avoid damaging the power cord. Do not bend it excessively, step on it, place heavy objects on it, etc. A damaged cord can easily become a shock or fire hazard. Never use a power cord after it has been damaged.
- In households with small children, an adult should provide supervision until the child is capable of following all the rules essential for the safe operation of the unit.
- Protect the unit from strong impact. (Do not drop it!)
- Do not force the unit's power-supply cord to share an outlet with an unreasonable number of other devices. Be especially careful when using extension cords—the total power used by all devices you have connected to the extension cord's outlet must never exceed the power rating (watts/amperes) for the extension cord. Excessive loads can cause the insulation on the cord to heat up and eventually melt through.
- Before using the unit in a foreign country, consult with your retailer, the nearest Roland Service Center, or an authorized Roland distributor, as listed on the "Information" page.
- Always grasp only the plug on the power-supply cord when plugging into, or unplugging from, an outlet or this unit.

#### ⚠ CAUTION

- Try to prevent cords and cables from becoming entangled. Also, all cords and cables should be placed so they are out of the reach of children.
- Never climb on top of, nor place heavy objects on the unit.
- Never handle the power cord or its plugs with wet hands when plugging into, or unplugging from, an outlet or this unit.
- If you need to move the instrument, take note of the precautions listed below. At least two persons are required to safely lift and move the unit. It should be handled carefully, all the while keeping it level. Make sure to have a firm grip, to protect yourself from injury and the instrument from damage.
- Check to make sure the knob bolts securing the unit to the stand have not become loose. Fasten them again securely whenever you notice any loosening.
  - Disconnect the power cord.
  - Disconnect all cords coming from external devices.
  - Close the lid.
  - Remove the music stand.
- Before cleaning the unit, turn off the power and unplug the power cord from the outlet (p. 14).
- Whenever you suspect the possibility of lightning in your area, pull the plug on the power cord out of the outlet.
- Be careful when opening/closing the lid so you do not get your fingers pinched (p. 14). Adult supervision is recommended whenever small children use the unit.
- When using the bench, please observe the following points:
  - Do not use the bench as a toy, or as a stepping stool.
  - Do not allow two or more persons to sit on the bench.
  - Do not sit on the bench if the bolts holding the bench legs are loose. (If the bolts are loose, immediately re-tighten them using the supplied wrench.)

# IMPORTANT NOTES

In addition to the items listed under “IMPORTANT SAFETY INSTRUCTIONS” and “USING THE UNIT SAFELY” on pages 2 and 3, please read and observe the following:

## Power Supply

- Do not use this unit on the same power circuit with any device that will generate line noise (such as an electric motor or variable lighting system).
- Before connecting this unit to other devices, turn off the power to all units. This will help prevent malfunctions and/or damage to speakers or other devices.

## Placement

- Using the unit near power amplifiers (or other equipment containing large power transformers) may induce hum. To alleviate the problem, change the orientation of this unit; or move it farther away from the source of interference.
- This device may interfere with radio and television reception. Do not use this device in the vicinity of such receivers.
- Observe the following when using the unit's floppy disk drive. For further details, refer to “Before Using Floppy Disks”.
  - Do not place the unit near devices that produce a strong magnetic field (e.g., loudspeakers).
  - Install the unit on a solid, level surface.
  - Do not move the unit or subject it to vibration while the drive is operating.
- Do not expose the unit to direct sunlight, place it near devices that radiate heat, leave it inside an enclosed vehicle, or otherwise subject it to temperature extremes. Excessive heat can deform or discolor the unit.
- To avoid possible breakdown, do not use the unit in a wet area, such as an area exposed to rain or other moisture.

## Maintenance

- For everyday cleaning wipe the unit with a soft, dry cloth or one that has been slightly dampened with water. To remove stubborn dirt, use a cloth impregnated with a mild, non-abrasive detergent. Afterwards, be sure to wipe the unit thoroughly with a soft, dry cloth.
- Never use benzine, thinners, alcohol or solvents of any kind, to avoid the possibility of discoloration and/or deformation.

## Repairs and Data

- Please be aware that all data contained in the unit's memory may be lost when the unit is sent for repairs. Important data should always be backed up on a floppy disk, or written down on paper (when possible). During repairs, due care is taken to avoid the loss of data. However, in certain cases (such as when circuitry related to memory itself is out of order), we regret that it may not be possible to restore the data, and Roland assumes no liability concerning such loss of data.

## Memory Backup

- If the power to this unit is not switched on for an extended period of time (about 2 weeks), the contents of memory will be lost, and the unit will revert to its factory defaults. To avoid the loss of important data that has been placed in memory, a backup of your data should be periodically created on a floppy disk

## Additional Precautions

- Please be aware that the contents of memory can be irretrievably lost as a result of a malfunction, or the improper operation of the unit. To protect yourself against the risk of losing important data, we recommend that you periodically save a backup copy of important data you have stored in the unit's memory on a floppy disk
- Unfortunately, it may be impossible to restore the contents of data that was stored on a floppy disk once it has been lost. Roland Corporation assumes no liability concerning such loss of data.
- Use a reasonable amount of care when using the unit's buttons, sliders, or other controls; and when using its jacks and connectors. Rough handling can lead to malfunctions.
- Never strike or apply strong pressure to the display.
- When connecting / disconnecting all cables, grasp the connector itself—never pull on the cable. This way you will avoid causing shorts, or damage to the cable's internal elements.
- A small amount of heat will radiate from the unit during normal operation.
- To avoid disturbing your neighbors, try to keep the unit's volume at reasonable levels. You may prefer to use headphones, so you do not need to be concerned about those around you (especially when it is late at night).
- When you need to transport the unit, package it in the box (including padding) that it came in, if possible. Otherwise, you will need to use equivalent packaging materials.

## Before Using Floppy Disks Handling the Floppy Disk Drive

- Install the unit on a solid, level surface in an area free from vibration. If the unit must be installed at an angle, be sure the installation does not exceed the permissible.
- Avoid using the unit immediately after it has been moved to a location with a level of humidity that is greatly different than its former location. Rapid changes in the environment can cause condensation to form inside the drive, which will adversely affect the operation of the drive and/or damage floppy disks. When the unit has been moved, allow it to become accustomed to the new environment (allow a few hours) before operating it.
- To insert a disk, push it gently but firmly into the drive—it will click into place. To remove a disk, press the EJECT button firmly. Do not use excessive force to remove a disk which is lodged in the drive.
- Never attempt to remove a floppy disk from the drive while the drive is operating (the indicator is lit); damage could result to both the disk and the drive.
- Remove any disk from the drive before powering up or down.
- To prevent damage to the disk drive's heads, always try to hold the floppy disk in a level position (not tilted in any direction) while inserting it into the drive. Push it in firmly, but gently. Never use excessive force.
- To avoid the risk of malfunction and/or damage, insert only floppy disks into the disk drive. Never insert any other type of disk. Avoid getting paper clips, coins, or any other foreign objects inside the drive.

## Handling Floppy Disks

- Floppy disks contain a plastic disk with a thin coating of magnetic storage medium. Microscopic precision is required to enable storage of large amounts of data on such a small surface area. To preserve their integrity, please observe the following when handling floppy disks:
  - Never touch the magnetic medium inside the disk.
  - Do not use or store floppy disks in dirty or dusty areas.
  - Do not subject floppy disks to temperature extremes (e.g., direct sunlight in an enclosed vehicle). Recommended temperature range: 10 to 50° C (50 to 122° F).
  - Do not expose floppy disks to strong magnetic fields, such as those generated by loudspeakers.

- Floppy disks have a “write protect” tab which can protect the disk from accidental erasure. It is recommended that the tab be kept in the PROTECT position, and moved to the WRITE position only when you wish to write new data onto the disk.

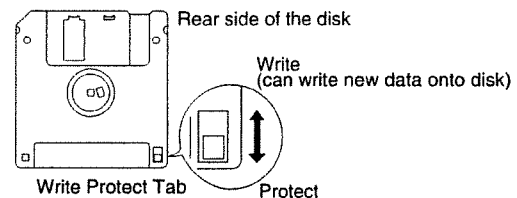

- The identification label should be firmly affixed to the disk. Should the label come loose while the disk is in the drive, it may be difficult to remove the disk.
- Store all disks in a safe place to avoid damaging them, and to protect them from dust, dirt, and other hazards. By using a dirty or dust-ridden disk, you risk damaging the disk, as well as causing the disk drive to malfunction.
- Disks containing performance data for this unit should always be locked (have their write protect tab slid to the “Protect” position) before you insert them into the drive on some other unit (except the PR-300, or a product in the HP-G, MT, KR, or Atelier families), or into a computer’s drive. Otherwise (if the write protect tab remains in the “Write” position), when you perform any disk operations using the other device’s disk drive (such as checking the contents of the disk, or loading data), you risk rendering the disk unreadable by this unit’s disk drive.

- \* GS ( ) is a registered trademark of Roland Corporation.
- \* Apple is a registered trademark of Apple Computer, Inc.
- \* Macintosh is a registered trademark of Apple Computer, Inc.
- \* IBM is a registered trademark of International Business Machines Corporation.
- \* IBM PC is a registered trademark of International Business Machines Corporation.

# FEATURES

We want to take a moment to thank you for your purchase of the Roland AT-20R "Atelier Series" Organ.

The AT-20R is an electronic organ which provides a generous collection of rich organ sounds. In addition, it is designed to be easy to learn and use. In order to enjoy reliable performance of your new keyboard for many years to come, please take the time to read through this manual in its entirety.

## Main Features

---

### ○ Simple and Easily Understood Operation

The large, color-coded buttons are organized by function, and laid out with an emphasis on ease of realtime operation. All models of the Atelier series use the same button arrangement, so that even beginners on the organ will be able to operate the instrument easily.

### ○ A Rich Array of Organ Sounds are Built-In

The AT-20R provides a rich array of organ sounds, including pipe organ, theatre organ, and jazz organ sounds.

### ○ Human voices

In addition to its diverse organ voices, the ATELIER-R series instruments also offer unique vocals, such as "Jazz Scat."

### ○ Harmony Intelligence

The AT-20R's Harmony Intelligence function detects chords played on the Lower keyboard, and automatically adds harmony to what is played on the Upper keyboard. This allows you to add harmonic richness to your playing and create a more impressive performance.

New on the AT-20R is a Harp-type Harmony Intelligence feature that lets you easily simulate the beautiful sonorities of a real harp.

### ○ Versatile Rhythms

The AT-20R contains 32 different Rhythms so you can enjoy playing along with the Rhythms of a variety of musical genres. In addition, the Arranger function lets you play an Automatic Accompaniment suitable for the Rhythm simply by using the Lower keyboard to specify a chord.

### ○ Disk Styles can be Loaded into Internal Memory

The Rhythm [Disk] button already contains 2 different Rhythms, but you can overwrite these with Rhythms loaded from a disk. When Rhythm data from a disk is loaded into internal memory, it will not be lost even if the power is turned off. It is convenient to load frequently-used disk Rhythms into internal memory.

○ **SMF Music Data can be Loaded**

The built-in composer features tape recorder-like operation. In addition to using the composer to easily record your playing, you can load SMF format music data and play along with it.

○ **SMF Save**

Since the AT-20R can save performance data in SMF format, performance data you create using an Atelier series organ can be easily edited on an external sequencer.

## Conventions Used in This Manual

- Button names are enclosed in square brackets (“[ ]”), as in [Demo] button.
- Whether a button light is illuminated, dark, or blinking is illustrated as shown below.



- Please be aware that although the display screens shown in this owner’s manual are generally based on the factory settings, some may not necessarily match the factory settings.
- [+][-], [▲][▼], [◀][▶] means that you should press one or the other button.  
Example: Rhythm Select [-][+] buttons, Part Balance Reverb [▲][▼] buttons, Menu [◀][▶] buttons

# Contents

Using the Unit Safety .....	2
IMPORTANT NOTES.....	4
<b>FEATURES .....</b>	<b>6</b>
Main Features .....	6
Conventions Used in This Manual .....	7
<b>Contents .....</b>	<b>8</b>
<b>Panel Descriptions .....</b>	<b>12</b>
<b>Before You Begin .....</b>	<b>14</b>
Opening/Closing the Lid .....	14
Setting Up the Music Stand .....	14
Connecting the Power Cord .....	14
Turning the Power On and Off .....	14
Turning On the Power .....	14
Turning Off the Power .....	15
Using Headphones .....	15
Some Notes on Using Headphones .....	15
Restoring All the Factory Default Settings .....	16
Displaying Basic Screens (Display/Exit Button) .....	16
Rhythm Screen .....	16
Composer Screen .....	16
<b>Start Playing the AT-20R .....</b>	<b>17</b>
Listening to the Demo Songs.....	17
Selecting Voices .....	19
About the Voices and Parts.....	19
Functions of the Upper/Lower/Pedal Bass Sound Select Buttons.....	20
Selecting the Upper and Lower Voices .....	20
Selecting Pedal Bass Voice .....	22
Selecting Solo Voice.....	23
Selecting a Voice Using the [Others] Button.....	24
Adjust the Volume Balance (Part Balance Buttons) .....	26
Transpose the Pitch in Octave Units (Oct Shift Button) .....	27
Playing Drums and Sound Effects on the Keyboard .....	28
Playing Drums from the Entire Lower Keyboard (Manual Drums).....	28
Changing the Drum Set Type .....	29
<b>Using the Rhythm (Music Style) Functions .....</b>	<b>30</b>
Selecting a Rhythm .....	30
Playing Rhythms—Starting and Stopping the Rhythm .....	31
Starting at the Press of a Button .....	31
Starting the Rhythm Automatically When You Play the Lower Keyboard or Pedalboard	
– Sync Start .....	31
Stopping the Rhythm .....	32
Adding Variation to the Rhythm .....	33
Playing Rhythm and Automatic Accompaniment .....	34
Changing the Tempo (Speed) (Tempo Button).....	34



A Simple Way to Make Automatic Accompaniment Settings — One Touch Program .....	35
Recalling Panel Settings Appropriate for Each Rhythm .....	36
Using a Rhythm (Music Style) from a Disk.....	37
Inserting and Ejecting a Floppy Disk.....	37
Playing the Disk Rhythms.....	37
Loading Disk Rhythms Into Internal Memory.....	38
Restoring the Rhythm Stored in the [Disk] Button to the Factory Settings .....	39
<b>Adding Various Effects to a Voice .....</b>	<b>40</b>
Adding Harmony to a Melody — Harmony Intelligence.....	40
Changing the Type of Harmony Intelligence .....	40
Rotary Effect.....	42
Reverb Effect.....	43
Sustain Effect.....	43
<b>Using the Play Functions .....</b>	<b>44</b>
Using the Lower Keyboard to Play the Bass Voice — [To Lower] Button .....	44
Transposing to a Different Key (Transpose Button) .....	45
Adjusting the Overall Volume Using an Expression Pedal.....	46
Adding Decay to the Sound (Damper Pedal) .....	46
Using the Foot Switch.....	47
<b>Using the Registration Buttons .....</b>	<b>48</b>
Storing Registrations.....	48
Recalling a Registration.....	49
How to Recall a Registration.....	49
Changing the Way in Which Registrations Are Recalled.....	49
Automatically Registering When You Switch Panel Settings .....	50
Assigning a Name to a Registration Set.....	50
Copying Only the Name of a Registration .....	52
Saving Registration Sets to a Floppy Disk (Save Button).....	53
Loading Previously Saved Registration Sets Into the AT-20R (Load Button).....	54
Loading a Set of Registrations .....	54
Loading an Individual Registration.....	55
Deleting a Previously Saved Registration Set.....	56
<b>Record and Playback Your Performance .....</b>	<b>57</b>
Recording Performances (Rec Button) .....	58
Recording Each Part Separately .....	59
Playing Back a Performance Song (Play Button).....	60
Silencing a Specific Track — Track Mute .....	61
Re-Recording .....	62
Erasing a Performance Song (Clear).....	63
Formatting Disks.....	64
Changing the Name of a Performance Song (Rename).....	66
Saving Performance Songs Onto Floppy Disk (Save Button).....	67
Saving in SMF Format.....	69
Loading Performance Songs Into the AT-20R.....	70
Layering a New Recording onto SMF Format Music Data .....	71
Playing Back Performance Songs Stored on Floppy Disk.....	72
Erasing Performance Songs Stored on Disk.....	73

## Contents

---

Re-Recording Part of Your Performance — Punch-in Recording .....	74
Repeatedly Layering Performances Over a Region — Loop Recording .....	76
<b>Settings for the Composer (Function Button) .....</b>	<b>78</b>
Count-in Recording .....	78
Changing the Metronome Setting .....	78
Metronome Volume .....	78
Changing the Sound of the Metronome .....	78
Setting the Beat .....	79
How the Expression Pedal Functions (Exp. Source) .....	79
Function During Recording .....	79
Function During Playback .....	80
Muting Individual Channels of Performance Data .....	80
Switching the Display of Lyrics On (Displayed) or Off (Not Displayed) .....	81
<b>Edit Menu (Editing Song Files) .....</b>	<b>82</b>
Delete Part of the Recorded Song (Delete Measure (Bar)) .....	82
Delete the Recording from a Track (Delete Track) .....	83
Erase Recording (Erase) .....	84
Copy Recording (Copy) .....	85
Correct Timing Inaccuracies (Quantize) .....	86
<b>Adjusting the Effects .....</b>	<b>87</b>
Changing the Reverb Type .....	87
Changing the Reverb Depth .....	88
Sustain Effect .....	88
Changing the Sustain Length .....	88
<b>Various Other Settings (Utility Button) .....</b>	<b>89</b>
Initial Touch (Initial Touch ON/OFF) .....	89
Pedal Bass Mode (How the Bass Pedalboard Can Be Played) .....	90
Solo Mode (Changing How the Solo Voice Will Sound) .....	90
Registration Shift (Use the Left Foot Switch to Switch Through Registration Buttons) .....	90
Left Foot Switch Assignment .....	90
Damper Pedal Assignment .....	91
Glide Destination .....	91
Manual Drums Set .....	92
Harmony Intelligence Type (Selecting the Type of the Harmony Intelligence) .....	92
Chord Intelligence (Chord Intelligence ON/OFF) .....	92
Chord Hold (Chord Hold ON/OFF) .....	92
Registration Arranger Update (Arranger Settings Recall Timing) .....	93
Registration Transpose Update (Transpose Setting Recall Timing) .....	93
Tx MIDI Channel (MIDI Output Channel) .....	93
MIDI IN Mode .....	94
Send PC Switch (Specifying Transmission of PC Numbers) .....	94
PC Number (Specifying PC Numbers) .....	94
Master Tune .....	95
LCD Contrast .....	95

---

**Connecting External Devices ..... 96**

- Names and Functions of Jacks and Connectors .....96
- Making the Connections .....96
  - Connecting Audio Equipment .....96
  - Connecting a Computer .....97
- If You're Using MIDI .....97
  - Connecting the AT-20R to a MIDI Instrument .....98

---

- Troubleshooting .....99
- Display Messages .....101
- Voice List .....103
- Drum Set List .....104
  - Manual Drum Set .....104
- Style List .....106
- Chord List .....107
- Settings That Are Stored After the Power Is Turned Off .....109
  - Settings That Are Stored After the Power Is Turned Off .....109
  - Settings That Are Stored in the Registration Buttons .....109
  - Settings That Are Stored in the Individual Registration Buttons .....109
- Glossary .....110
  - About ATELIER Series Sound Generator .....111
- MIDI Implementation Chart.....112
- Main Specifications .....113
- Index .....115
- Demo Song List .....117

# Panel Descriptions

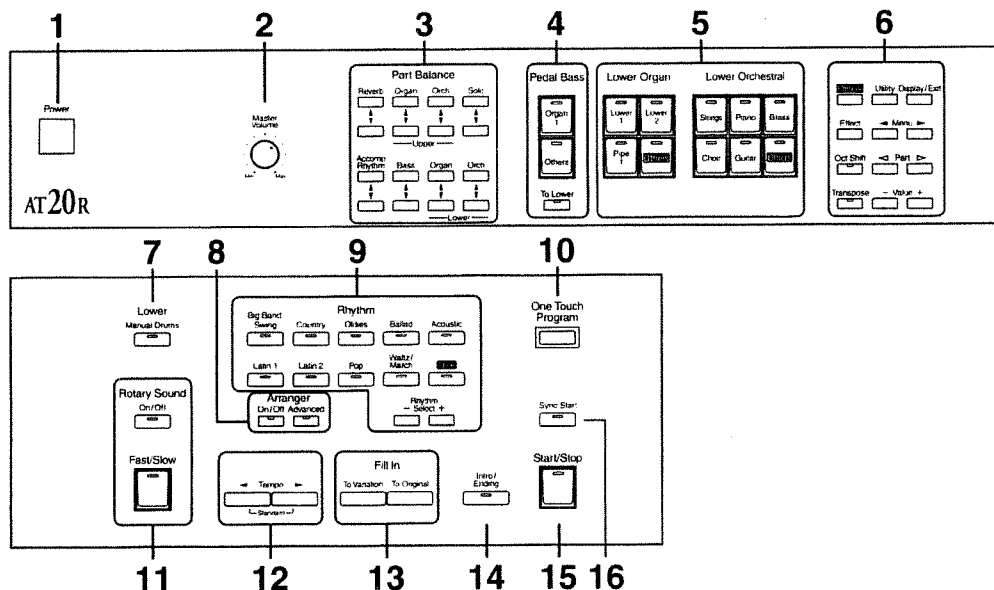

- |  |   |
|--|---|
| <p><b>1</b> [Power] switch ( → p. 14)</p> <p><b>2</b> [Master Volume] knob ( → p. 14)</p> <p><b>3</b> Part Balance [▲] [▼] button ( → p. 26, p. 43)</p> <p><b>4</b> Pedal Bass Voice select buttons ( → p. 22)<br/>Pedal Bass Part<br/>[To Lower] button ( → p. 44)</p> <p><b>5</b> Lower Voice select buttons ( → p. 20)<br/>Lower Organ part<br/>Lower Orchestral part</p> <p><b>6</b><br/>[Others] button ( → p. 24)<br/>[Effect] button ( → p. 87)<br/>[Oct Shift] button ( → p. 27)<br/>[Transpose] button ( → p. 45)<br/>[Utility] button ( → p. 89-p. 95)<br/>[Display/Exit] button ( → p. 16)<br/>Menu [◀] [▶] buttons<br/>Part [◀] [▶] buttons<br/>Value [-] [+] buttons</p> <p><b>7</b> [Manual Drums] button ( → p. 28)</p> | <p><b>8</b><br/>Arranger [On/Off] button ( → p. 34)<br/>[Advanced] button ( → p. 33)</p> <p><b>9</b> Rhythm select buttons ( → p. 30)<br/>Rhythm Select [-] [+] buttons ( → p. 30)</p> <p><b>10</b> [One Touch Program] button ( → p. 35)</p> <p><b>11</b> Rotary Sound ( → p. 42)<br/>[On/Off] button<br/>[Fast/Slow] button</p> <p><b>12</b> Tempo [◀] [▶] button ( → p. 34)</p> <p><b>13</b> Fill In ( → p. 33)<br/>[To Variation] button<br/>[To Original] button</p> <p><b>14</b> [Intro/Ending] button ( → p. 31)</p> <p><b>15</b> [Start/Stop] button ( → p. 31)</p> <p><b>16</b> [Sync Start] button ( → p. 31)</p> |
|--|---|

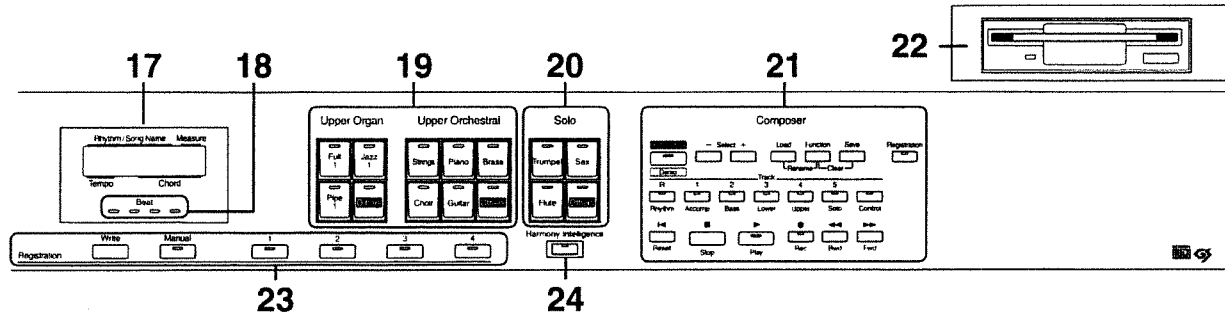

- 17 Display** ( → p. 16)
- 18 Beat Indicator** ( → p. 34)
- 19 Upper voice select buttons** ( → p. 20)  
Upper Organ part  
Upper Orchestral part
- 20 Solo voice select buttons** ( → p. 23)  
Solo part
- 21 Composer**  
[All Song Play/Demo] button ( → p. 17, p. 72)  
Select [-] [+] buttons  
[Load] button ( → p. 54, p. 55, p. 70)  
[Function] button ( → p. 78-p. 86)  
[Save] button ( → p. 53, p. 67)
- 22 Disk Drive** ( → p. 37)
- 23 Registration buttons**  
[Write] button ( → p. 48)  
[Manual] button ( → p. 50)  
Registration [1] - [4] buttons ( → p. 48)
- 24 [Harmony Intelligence] button** ( → p. 40)
- [Registration] button** ( → p. 50-p. 56)
- Track buttons** ( → p. 57, p. 61)
- [Reset] button**
- [Stop] button**
- [Play] button** ( → p. 60, p. 72)
- [Rec] button** ( → p. 58, p. 59, p. 62)
- [Bwd] button**
- [Fwd] button**

■ **Rear Panel** ( → p. 96)

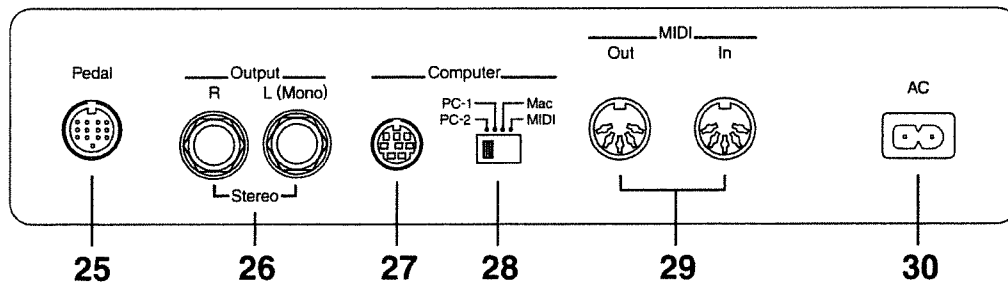

- 25 Pedal connector**
- 26 Output L (mono) /R jacks**
- 27 Computer connector**
- 28 Computer switch**
- 29 MIDI Out / In connectors**
- 30 AC Inlet**

# Before You Begin

## Opening/Closing the Lid

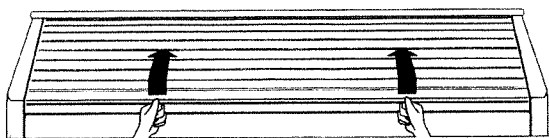

1. To open the lid, hold it with both hands and slide it to the rear.
  2. To close the lid, slowly pull it forward until it stops.
- \* Be careful not to get your fingers caught when opening or closing the lid. Adult supervision is recommended when small children are going to be using the instrument.
  - \* To prevent accidents, be sure to close the lid before moving the organ.
  - \* Make sure you don't have anything (such as sheet music) on the keyboard when you close the lid.

## Setting Up the Music Stand

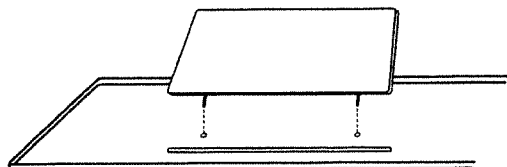

1. Attach the music stand by inserting it into the two holes.

## Connecting the Power Cord

1. First, make sure that the [Power] switch at the panel's left side is OFF (not pushed in).
2. Connect the supplied power cord to the AC Inlet connector, then plug the other end into an AC outlet.

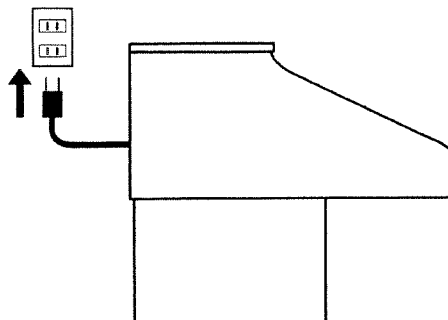

- \* Only use the power cord supplied with this instrument.
- \* Whenever you do not intend to use the instrument for extended periods of time, pull out the power cord from the AC outlet.

## Turning the Power On and Off

- \* Once the connections have been completed, turn on or off power to your various devices in the order specified. By turning on or off devices in the wrong order, you risk causing malfunction and/or damage to speakers and other devices.

## ■ Tuning On the Power

1. Make sure of the following before the power is turned on.
  - Is the power cable correctly connected to the AC inlet?
  - Is the power cable correctly connected to the AC outlet?
  - Is the [Master Volume] knob (located at the left of the Lower keyboard) set to the Min (minimum) position?

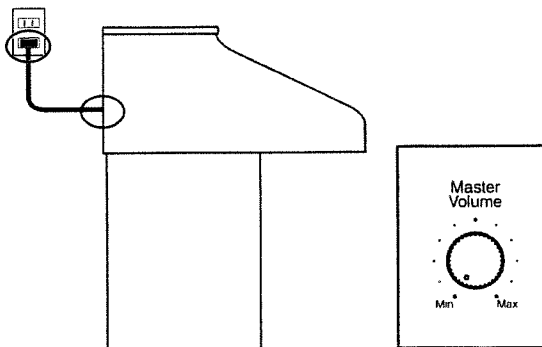

**2. Press the [Power] switch to turn on the power.**



\* This unit is equipped with a protection circuit. A brief interval (a few seconds) after power up is required before the unit will operate normally.

**3. The [Master Volume] knob located on the left of the Lower Keyboard panel is an overall control for adjusting the volume of the entire instrument.**

Position the Expression Pedal to the half-way mark. Now adjust the [Master Volume] knob to a suitable level. Now that this level has been set, you can use the Expression Pedal to change the volume with your foot as you play the AT-20R. The volume will be increased when the Expression Pedal is pressed down, and decreased when the pedal is returned.

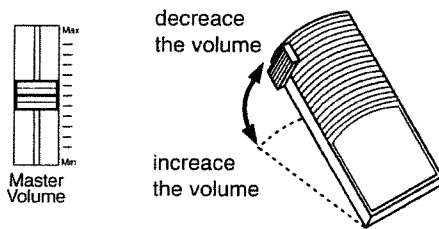

**■ Turning Off the Power**

- 1. Before switching the power off, set the [Master Volume] knob to the Min (minimum) position.**
- 2. Press the [Power] switch to turn off the power.**

**Using Headphones**

The AT-20R features a Phones jack. This allows you to play without having to worry about bothering others around you, even at night.

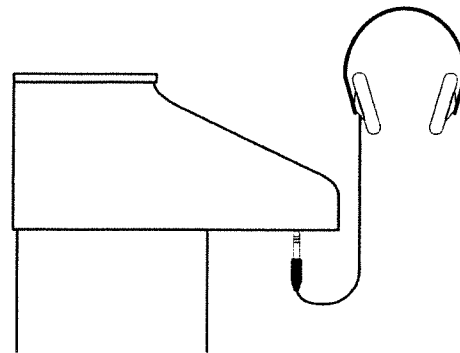

**1. Connect the headphones to the Phones jack on the underside of the unit.**

The sound from the built-in speakers stops. Now, sound is heard only through the headphones.

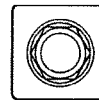

**2. Adjust the headphones volume with the [Master Volume] slider and Expression pedal.**

\* Accepts connection of Stereo headphones.

- To prevent damage to the cord, handle the headphones only by the headset or the plug.
- Headphones may be damaged if the volume is too high when they are plugged in. Lower the volume on the AT-20R before plugging in headphones.
- To prevent possible auditory damage, loss of hearing, or damage to the headphones, the headphones should not be used at an excessively high volume. Use the headphones at a moderate volume level.

## Before You Begin

### Restoring All the Factory Default Settings

The settings stored in the AT-20R can be returned to their factory settings. This function is called "Factory Reset."

1. **Make sure there is no floppy disk in the disk drive before carrying out the procedure.**
2. **Turning off the power.**
3. **While holding down the [One Touch Program] button, press the [Power] switch to turn the power on.**

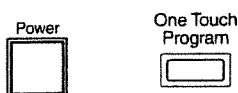

The following display appears.

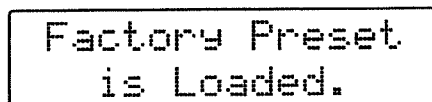

- \* Loading factory default settings will erase any Registrations currently in the memory of the AT-20R. To save the registrations you are currently using, refer to page 53.
- \* Even if you perform the Factory Reset operation, the Rhythm [Disk] button will not return to the factory settings. If you wish to return the Rhythm [Disk] button to the factory settings, please refer to page 39.
- \* When you are using the instrument for the very first time, or it has remained unused for about two weeks or so, it will automatically be returned to the factory default settings when the power is turned on.

### Displaying Basic Screens (Display/Exit Button)

The instrument's display provides a large variety of information. The AT-20R has two types of basic display screen: the Rhythm display, and the Composer display. You can alternate from one to the other by pressing the [Display/Exit] button.

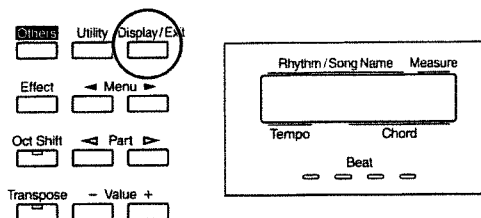

#### ■ Rhythm Screen

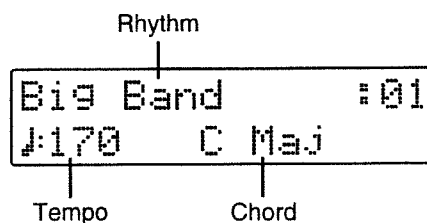

#### ■ Composer Screen

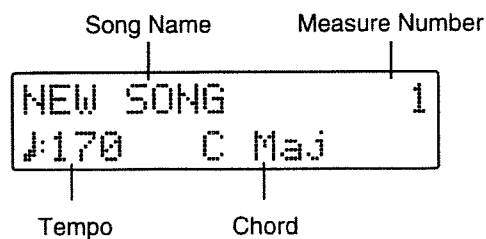

When you have selected a performance song on a floppy disk:

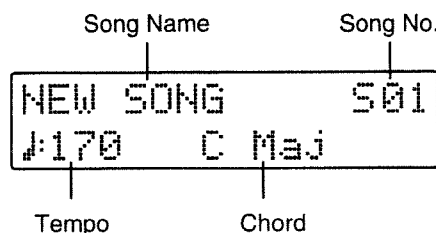



# Start Playing the AT-20R

## Listening to the Demo Songs

The AT-20R contains 3 Demo songs. Here's how to play the Demo songs, and fully appreciate the sounds, Rhythms, and Automatic Accompaniment that are available with the AT-20R.

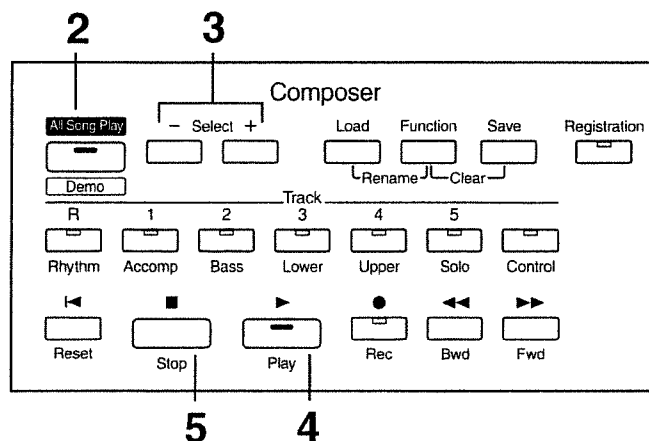

- 1. Make sure that a floppy disk is not inserted in the disk drive.**  
If a floppy disk is in the disk drive, press the Eject button (p. 37) and remove the floppy disk.
  - 2. Press the [All Song Play/Demo] button (the indicator will light).**  
All track indicator will light.
- ```
Big Band      :01  
DEMO [-/+PLAY]
```
- 3. Use the [-] and [+] Composer Select buttons to select a Demo song.**
  - 4. Press the [Play] button.**  
When the selected demo song ends, the next demo song will begin playing.
  - 5. To stop playback in the middle of the song, press the [Stop] button.**  
The [All Song Play/Demo] button's indicator will be turned off.



Check out the "Demo Song List" (p. 117) for information such as the names of the composers and players of the demo songs.

## Start Playing the AT-20R

---

### ● If the Following Screen Appears

If the performance song in the unit has not been saved to a floppy disk, the following message will appear, and it will not be possible to play the Demo songs.

```
Clear Song Sure?  
Yes:REC No:RST
```

If you don't mind erasing this song, press the [Rec] button. However, if you wish to save this song, press the [Reset] button to cancel the procedure, and then save the song onto a floppy disk.



*If you wish to save the musical data to a floppy disk, refer to "Saving Performance Songs Onto Floppy Disk (Save Button)" (p. 67).*



*All rights reserved. Unauthorized use of this material for purposes other than private, personal enjoyment is a violation of applicable laws.*



*The data for the Demo song that is being played is not available at the MIDI Out connector.*

## Selecting Voices

The AT-20R is able to produce the sounds of various instruments. These sounds are called "Voices" (or tones). It is very easy to select voices.

### ■ About the Voices and Parts

The AT-20R has two keyboards and one Bass Pedalboard, as shown below. From top to bottom these are called the "Upper Keyboard," "Lower Keyboard," and "Bass Pedalboard."

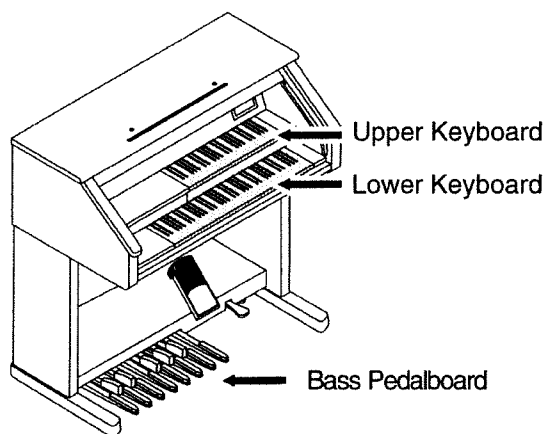

The Upper Keyboard and Lower Keyboard each have two parts: "Organ," "Orchestral." You can select one voice for each part, meaning that it is possible to layer up to two voices on each keyboard and play them simultaneously.

The voice of the "Solo" part can be layered on the Upper keyboard.

The Bass Pedalboard has the part: "Pedal Bass."

| Keyboard        | Type of voices | Parts            |
|-----------------|----------------|------------------|
| Upper Keyboard  | Upper          | Upper Organ      |
|                 |                | Upper Orchestral |
|                 |                |                  |
| Lower Keyboard  | Lower          | Solo             |
|                 |                | Solo             |
| Lower Keyboard  | Lower          | Lower Organ      |
|                 |                | Lower Orchestral |
| Bass Pedalboard | Pedal Bass     | Pedal Bass       |

## ■ Functions of the Upper/Lower/Pedal Bass Sound Select Buttons

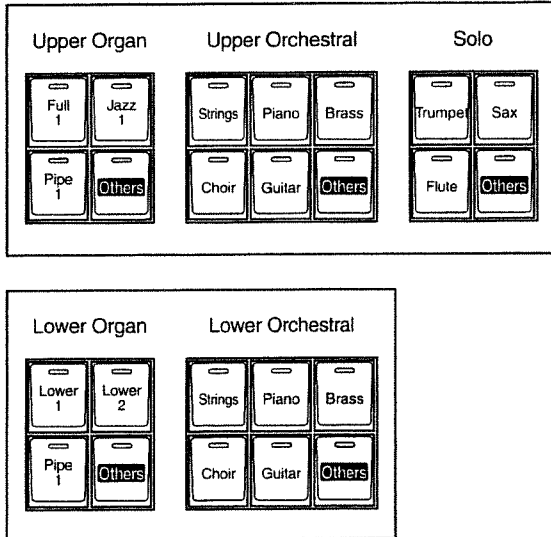

Each time you press a voice button, its indicator will switch between being lit and being turned off. Voices that have their button indicator lit can be played.

### **NOTE**

*If none of the voice buttons are lit, playing the keyboard will not produce a sound.*

## ■ Selecting the Upper and Lower Voices

Press the "Organ," or "Orchestral" buttons for each Keyboard (Upper/Lower) to select the desired voice.

When the power is turned on, the Upper keyboard will play "Full Organ 1" and the Lower keyboard will play "Lower Organ1."

### **Example: Selecting "Jazz Organ 1" for the Upper Organ part, and "Grand Piano" for the Upper Orchestral.**

#### **1. Press the Upper Organ [Jazz 1] button (indicator lights).**

The name of the selected voice will appear in the display for several seconds.

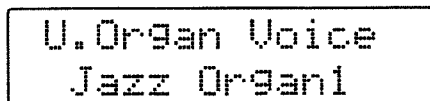

Now when you play the Upper keyboard, the "Jazz Organ1" will sound.

#### **2. Press the Upper Orchestral [Piano] button (the indicator lights).**

Now when you play the Upper keyboard, the two voices "Jazz Organ1" and "Grand Piano" will sound simultaneously (mixed together).

**The Organ voices Full Organ 1 to Full Organ 6 are actually preset combinations of different organ footages with combinations as follows:**

Full Organ 1 - 80 0000 004  
Full Organ 2 - 88 8000 008  
Full Organ 3 - 80 8808 008  
Full Organ 4 - 80 0800 000  
Full Organ 5 - 85 3111 246  
Full Organ 6 - 88 8888 888

**For example: a combination of "85 3111 246" means the following levels have been set:**

16' is set at 8 (maximum)  
8' is set at 5  
5 1/3' is set at 3  
4' is set at 1  
2 2/3' is set at 1  
2' is set at 1  
1 3/5' is set at 2  
1 1/3' is set at 4  
1' is set at 6

Similarly, the "Jazz" organ voices are actually preset combinations of different Jazz organ footages and percussion with combinations as follows:

Jazz Organ 1 - 88 8000 000 with 3rd harmonic percussion  
Jazz Organ 2 - 88 8800 000 with 3rd harmonic percussion  
Jazz Organ 3 - 80 0800 000 with 2nd harmonic percussion  
Jazz Organ 4 - 88 8000 000 with 2nd harmonic percussion  
Jazz Organ 5 - 88 8800 000 with 2nd harmonic percussion  
Jazz Organ 6 - 88 8630 000 with 3rd harmonic percussion

Likewise the "Pipe" organ and "Theater" organ voices are actually preset combinations of classical pipe and theater organ sounds experienced on our famous Rodgers organs. The Upper and Lower keyboards each have three parts; Organ, Symphonic, and Orchestral. One voice can be selected from each part, allowing you to mix (layer) up to 3 voices. Voices can be selected for the Lower keyboard in the same way as for the Upper keyboard.

Like the Upper keyboard organ voices, the Lower organ voices are actually preset combinations of different organ footages with combinations as follows:

Lower Organ 1 - 00 8000 000  
Lower Organ 2 - 00 8400 000  
Lower Organ 3 - 00 8503 000  
Lower Organ 4 - 00 8000 005  
Lower Organ 5 - 00 8640 000  
Lower Organ 6 - 00 8402 001

---

### ■ Selecting Pedal Bass Voice

Immediately after the power is turned on, the Pedal Bass voice will sound single notes using the "Organ Bass 1" voice. Here's how to select Bass voice played by the Pedalboard.

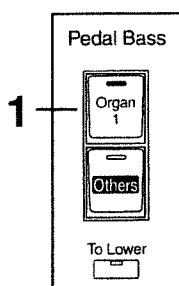

#### 1. Press the Pedal [Organ 1] button (indicator lights).

The name of the selected voice will appear in the display for several seconds.

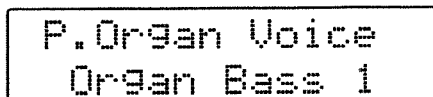

Now when you play the Pedalboard, "Organ Bass 1" will be heard.



*Settings can be adjusted to allow multiple notes to be played on the Pedalboard (p. 90)*



*If you press the [To Lower] button (indicator lights p. 44), the Bass voice can now be played by the Lower keyboard, not by the Pedalboard.*

## ■ Selecting Solo Voice

The Solo section of the Upper keyboard is monophonic, that is, the Solo voice will only sound for the highest note played on the Upper keyboard. This allows you to play full chords and have the selected Solo voice playing the highest (solo) note.

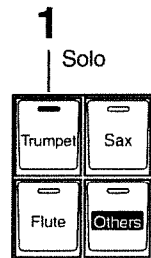

### 1. Press the Solo [Trumpet] button (indicator lights).

The name of the selected voice will appear in the display for a few seconds.

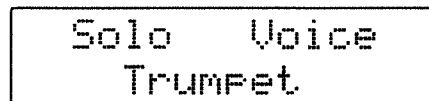

Play the Upper keyboard. The selected voice will sound by the highest note played.



*It is possible to change how a Solo voice will sound.*

*Normally, the Solo voice will be sounded by the highest note you play on the Upper keyboard, but you can make settings so that the last-played note will sound the Solo voice. You can also make settings so that the Solo voice will be sounded by all notes of the keyboard to which the Solo voice is assigned. For details refer to "Solo Mode (Changing How the Solo Voice Will Sound)" (p. 90).*

## ■ Selecting a Voice Using the [Others] Button

Notice that there is an [Others] button for each of the “Organ,” “Orchestral” sections of the Upper and Lower voices, for the “Solo” section, and for the “Pedal Bass” sections of the Pedal bass voice. By using the [Others] buttons, you can select from all internal voices of the AT-20R.

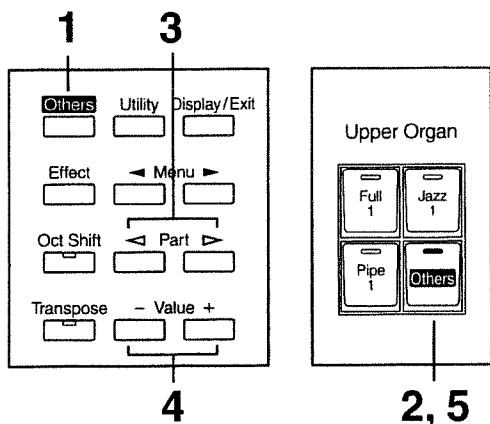

**1. Press the [Others] button to the left of the display.**

All [Others] buttons begin to flash.

**2. Press the [Others] button for the section (Part) to which you wish to assign a voice.**

The indicator of the selected [Others] button will blink, and the indicators of the remaining [Others] buttons will change from blinking to dark.

**3. Use the [◀] and [▶] Part buttons to select a voice group.**

The voice number of each voice is preceded by an alphabetical character A–T which indicates the voice group; e.g., “G11 Strings1.”

**4. Use the [-] and [+] Value buttons to select the desired voice.**

The name of the selected voice is shown in the display.

```
Others Select
E13 Theater Or.3
```

**5. Once again, press the [Others] button for the part to which the selected voice will be assigned.**

The selected voice is now stored, and will be retained even while the instrument is switched off.



To stop mid-way through this or any procedure, press the [Display/Exit] button.





About the voices that can be assigned to an [Others] button, please refer to "Voice List" (p. 103).

---

### ○ **Shortcut When Selecting Voices for Any [Others] Button**

Instead of using the general [Others] button located at the left of the display, here's a quicker way to select voices for any [Others] button.

#### **1. Press the [Others] button for the Part for which you wish to specify a voice.**

The voice name will appear in the display.

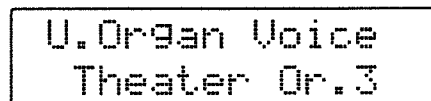

#### **2. While the voice name is shown in the display screen, use the Value [-] [+] buttons to select the desired voice.**

The indicator of the selected [Others] button will blink.

#### **3. Once again, press the [Others] button for the part whose sound you wish to set to confirm the voice.**

The indicator of the [Others] button will change from blinking to lit.



*When you press the [Others] button, the voice name will appear in the display screen, but the basic screen will reappear if you wait several seconds without pressing the Value [-] [+] buttons. If you wish to change the sound that is assigned to the [Others] button, press the [Others] button, and quickly use the Value [-] [+] buttons to select the desired voice while the voice name is still shown in the display screen.*

---

## Adjust the Volume Balance (Part Balance Buttons)

The AT-20R allows you to adjust the volume balance individually for each Part.

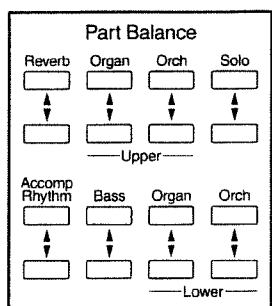

The following buttons are used to adjust the volume of a multiple number of Parts.

**Accomp Rhythm button:**

Automatic Accompaniment (except bass)

Playback of performance data from something other than the Atelier, Rhythm performance, Manual Drums

**Bass button:**

Pedal Bass Voice, Bass part of Automatic Accompaniment

1. **The volume levels of each part are adjusted using the corresponding [ ▲ ] and [ ▼ ] buttons.**

When you press the up button ( ▲ ), the volume increases; when you press the down button ( ▼ ), the volume decreases.

The volume can be set to any value from 0 to 12.

When you press the Part Balance [ ▲ ][ ▼ ] buttons, the volume for each part will be shown in the display.



*When the volume value shown in the display is 0, that part will produce no sound.*

## Transpose the Pitch in Octave Units (Oct Shift Button)

Octave Shift is a function that allows you to alter the pitch of what is played by one or two octaves.

You can apply an Octave shift to the following 6 Parts:  
 All of the Upper and Lower Parts (Organ/Orchestral)  
 The Bass Parts (Pedal Bass)  
 The Solo Part

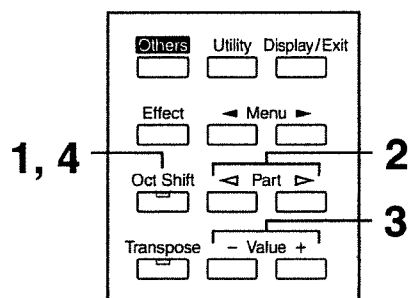

**1. Press the [Oct Shift] button.**

The [Oct Shift] button's indicator begins to flash.

**2. Use the [◀] and [▶] Part buttons to select a performance Part to which you wish to apply an Octave Shift.**

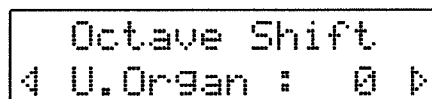

**3. Use the [-] and [+] Value buttons to set the amount of shift.**

The value can be set to a range of +/- 2 octaves.

**4. Press the [Oct Shift] button.**

The basic screen will reappear

When all Parts are set to value 0, the [Oct Shift] button's indicator goes off.

When any Part is set to any value other than 0, the [Oct Shift] button's indicator will light.



*Please note that when you apply the Octave Shift function to certain voices, their pitch could be stretched beyond their recommended note ranges, and they may not sound as expected. Care should be taken when using Octave Shift.*

## Playing Drums and Sound Effects on the Keyboard

---

### ■ Playing Drums from the Entire Lower Keyboard (Manual Drums)

You can use the Lower keyboard to play various drum sounds (drum set). In this case, the Lower voices will no longer sound.

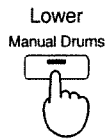

#### 1. Press the [Manual Drums] button (indicator lights).

Play the Lower keyboard and listen to the various drum sounds on each key. The [Manual Drums] button will alternate between on (lit) and off each time it is pressed.

Immediately after the power is turned off, the STANDARD drum set will sound.



*Refer to "Drum Set List" (p. 104) for details on which drum sound or Sound Effect will be played by each note.*

## ■ Changing the Drum Set Type

As the drum set, you can choose from 8 types of drum set and one type of sound effect. When you change the drum set, the sound produced by each note will change. Immediately after the power is turned on, the STANDARD drum set will sound. Let's try selecting a different Drum Set or the Sound Effect set.



Refer to "Drum Set List" (p. 104) for details on which drum sound or Sound Effect will be played by each note.

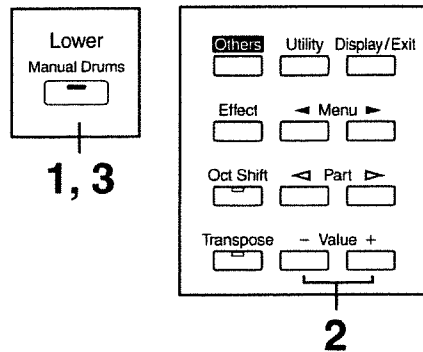

1. Press the [Manual Drums] button (indicator lights).
2. When the Drum Set name is displayed on the screen, press the [-] or [+] Value button to select a Drum Set or Sound Effect Set.

The [Manual Drums] button indicator will begin to flash.

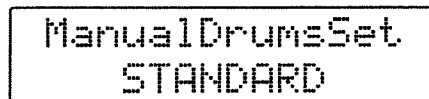

You can select from 8 different Drum Sets and one set of Sound Effects as follows:

**STANDARD, ROOM, POWER, ELECTRONIC, TR-808, JAZZ, BRUSH, ORCHESTRA, SOUND EFFECTS**

3. Press the [Manual Drums] button once again.

The [Manual Drums] button indicator will be lit constantly, and the selected Drum Set Type will be applied.



To stop mid-way through this or any procedure, press the [Display/Exit] button.



The Drum Set Type can also be selected from the Utility menu. Please refer to "Manual Drums Set" (p. 92).

# Using the Rhythm (Music Style) Functions

The AT-20R lets you enjoy playing along with a rhythmic accompaniment.

## Selecting a Rhythm

The AT-20R provides 32 types of Rhythms and Automatic Accompaniments (Music Styles). These are organized into 10 groups.

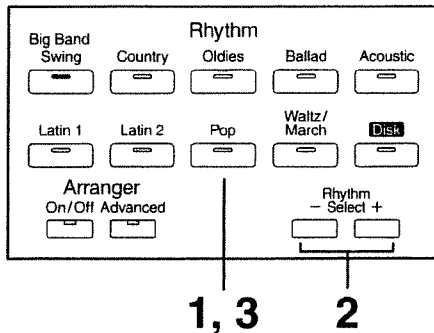

### 1. Press a Rhythm button to select a Rhythm group.

The indicator will light, and the first Rhythm in the group will be selected. That Rhythm will be shown in the display.

```
BigBandSwing
♩:109 C Maj
```

### 2. To select a different Rhythm within the same group, use the [-] and [+] Rhythm Select buttons.

The indicator of the Rhythm button will flash.

### 3. Press the Rhythm button once again (indicator lights constantly).

The Rhythm button's indicator will change from blinking to light. The Rhythm has now been applied.

#### ○ Using the Rhythms of the [Disk] Button

The [Disk] button contains 2 preset Rhythms. These Rhythms can be rewritten by loading disk styles into the AT-20R.

Styles that are already written in the [Disk] button memory can be selected in the same way as when selecting Rhythms of another Rhythm group.



*If you wish to store a disk style in the [Disk] button, refer to "Loading Disk Rhythms Into Internal Memory" (p. 38).*

## Playing Rhythms—Starting and Stopping the Rhythm

There are two ways to start the Rhythm:

1. Manually by pressing a button,
  2. Automatically by playing a note on the Lower keyboard or Pedalboard (Syncro Start).
- You can also make the Rhythm start after playing an Intro, or make the Rhythm stop after playing an Ending.

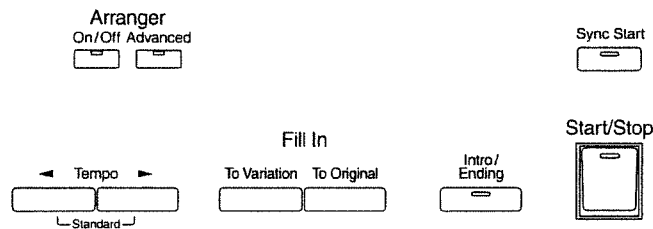

### ■ Starting at the Press of a Button

#### ○ Starting with an Intro

1. Press the [Intro/Ending] button.

The Intro is played and the Rhythm starts.

While the Intro is playing, the [Intro/Ending] button indicator will light, until the Intro ends then the button indicator will go dark.

#### ○ Making the Intro Short and Simple

1. Press the [To Variation] or [To Original] button.

2. Press the [Start/Stop] button.

A short Intro is played and the Rhythm starts.

#### ○ Starting without an Intro

1. Press the [Start/Stop] button.

The Rhythm starts without an Intro being played.

### ■ Starting the Rhythm Automatically When You Play the Lower Keyboard or Pedalboard – Sync Start



*If the Arranger function is ON (the Arranger [On/Off] button indicator is lit), it is not be able to start the Rhythm by playing the Pedalboard.*

#### ○ Starting with an Added Intro

1. Press the [Sync Start] button to make the indicator light up.

## Using the Rhythm (Music Style) Functions

---

### **2. Press the [Intro/Ending] button.**

The [Intro/Ending] button's indicator will flash.

### **3. Play either the Lower keyboard or the Pedalboard.**

The Intro is played and the Rhythm starts.

While the Intro is playing, the [Intro/Ending] button indicator will light, until the Intro ends the button indicator will be turned off.

#### ○ **Making the Intro Short and Simple**

##### **1. Press the [Sync Start] to make the indicator light up.**

##### **2. Press the [To Variation] or [To Original] button.**

[Start/Stop] button indicator will flash.

Pressing the [To Variation] or [To Original] button makes the Rhythm pattern change as well.

##### **3. Play either the Lower Keyboard or the Pedalboard.**

A short Intro is played and the Rhythm starts.

#### ○ **Starting without an Intro**

##### **1. Press the [Sync Start] button (the indicator lights).**

##### **2. Play either the Lower keyboard or the pedalboard.**

The Rhythm starts without an Intro being played.

## ■ **Stopping the Rhythm**

#### ○ **Stopping with an Ending**

##### **1. Press the [Intro/Ending] button.**

An Ending is played, then the Rhythm stops.

While the Ending is playing, the [Intro/Ending] button indicator will flash, until the Ending finishes the button indicator will be turned off.

#### ○ **Making the Ending Short and Simple**

##### **1. Press the [To Variation] or [To Original] button, and then press the [Start/Stop] button.**

A short Ending is played, then the Rhythm stops.

#### ○ **Stopping without an Ending**

##### **1. Press the [Start/Stop] button.**

The Rhythm will stop without an Ending being played.



## Adding Variation to the Rhythm

You can add variation to the Rhythm by changing the arrangement or by switching the Rhythm pattern.

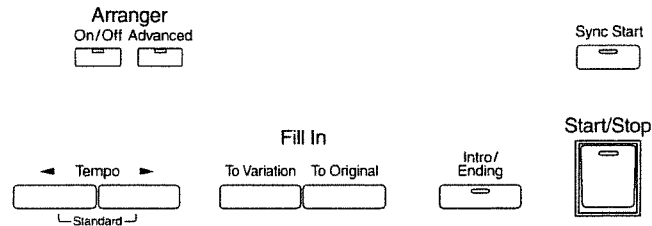

| Button                               | Function                                                             |
|--------------------------------------|----------------------------------------------------------------------|
| <b>Arranger [Advanced] button</b>    | Basic Arrangement (indicator off) / Full Arrangement (indicator lit) |
| <b>Fill In [To Variation] button</b> | After the fill-in has played, play the Variation Rhythm pattern      |
| <b>Fill In [To Original] button</b>  | After the fill-in has played, play the Original Rhythm pattern       |

### What is a Fill In?

A fill-in is a short phrase that is inserted at a break in the melody or at a point where the character of the song changes (between Chorus's or Verses).



*The functions of the [Start/Stop] button, the [To Variation] button, the [To Original] button and [Advanced] button can be assigned to the foot switch located on the left side of the Expression Pedal (p. 90).*

## Playing Rhythm and Automatic Accompaniment

The Arranger function of the AT-20R can add an Automatic Accompaniment to each Rhythm. Based on the selected Rhythm, the Arranger function automatically adds an accompaniment that is suitable for the chord being pressed on the Lower keyboard.

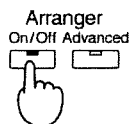

### 1. Press the Arranger [On/Off] button (indicator lights.)

**Indicator is lit (On)** Rhythm and Automatic Accompaniment  
**Indicator is not lit (Off)** Rhythm (Drums only)



If the Arranger[On/Off] button is ON and no Pedal bass voice is selected, the Automatic Accompaniment will play the bass sound.



While the Intro or Ending is being played, the Lower keyboard voices will not play.

## Changing the Tempo (Speed) (Tempo Button)

You can change the tempo of the Rhythm or Automatic Accompaniment.

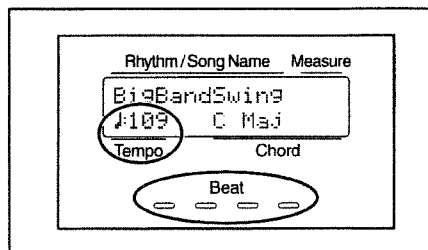
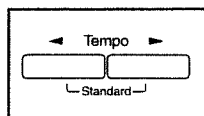

### 1. Press the [ ◀ ] and [ ▶ ] Tempo buttons to change the tempo (speed) of the Rhythm or Automatic Accompaniment.

Tempo [ ◀ ] button The tempo becomes slower  
Tempo [ ▶ ] button The tempo becomes faster



By pressing the [ ◀ ] and [ ▶ ] Tempo buttons simultaneously, the tempo is returned to the standard (preset) tempo for the selected Rhythm.

The value of the tempo currently set (20~250 beats per minute) can be checked in the display.

You can also check the tempo by viewing the Beat indicator. The indicator flashes red on the first beat of the measure (bar), and green on the remaining beats.

## A Simple Way to Make Automatic Accompaniment Settings — One Touch Program

---

In addition to the Rhythm, you can also play an Automatic Accompaniment. The AT-20R provides a very convenient [One Touch Program] button. By simply pressing this button once, the Arranger function will be turned ON, and keyboard voices that are most appropriate for playing with the currently selected Rhythm/Automatic Accompaniment are selected.

By pressing the [One Touch Program] button, you can make the following settings.

### ○ When the Rhythm is Stopped

- [Sync Start] button lit, [Intro/Ending] button blinking (Waiting for Sync Start)
- Arranger [On/Off] button lit (Automatic Accompaniment playing)
- Panel appropriate for the Rhythm

### 1. Select a Rhythm (p. 30).

### 2. Press the [One Touch Program] button.

Panel settings suitable for the selected Rhythm and Automatic Accompaniment will be selected automatically.

### 3. On the Lower keyboard, play a chord.

At the moment you play the keyboard, the Intro will begin, and then the Rhythm and Automatic Accompaniment will play.



*While the Intro or Ending is being played, the Lower keyboard voices will not play.*

## Using the Rhythm (Music Style) Functions

---

### ■ Recalling Panel Settings Appropriate for Each Rhythm

For each of the Rhythms (Music Styles) built into the AT-20R, there are 2 types of available panel settings, which are appropriate for use with that Rhythm (Music Style). These can be stored at Registration buttons [1] – [2].



*If this procedure is carried out, the Registrations that were previously at Registration buttons [1] – [2] will be lost. If you wish to retain them, use the procedure explained on page 53 to save them to a floppy disk.*

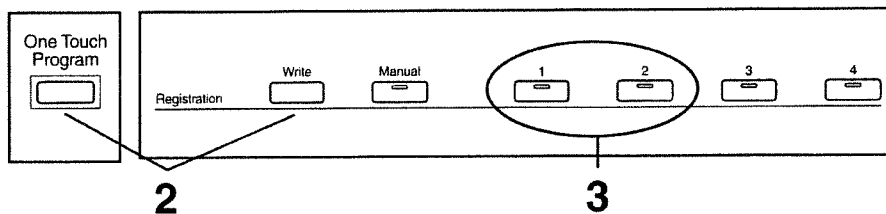

- 1.** Select a Rhythm (p. 30).
- 2.** While holding the Registration [Write] button, press the [One Touch Program] button.  
The panel settings appropriate for the Rhythm will now be stored in Registration buttons [1] – [2].
- 3.** To recall and use the panel settings that you have stored, press one of the Registration buttons [1] – [2].

## Using a Rhythm (Music Style) from a Disk

The AT-20R contains 32 types of built-in Rhythms (Music Styles). Additional Rhythms (Music Styles) are available on the Music Style disk included are available. Here's how to select a Rhythm (Music Style) from a Music Style disk.

### ■ Inserting and Ejecting a Floppy Disk

**NOTE** *If you're using the disk drive for the first time, be sure to read the important notes on page 5.*

- 1. Hold the floppy disk with the label facing upwards, and push it into the disk drive until it clicks into place.**

The disk drive is on the right side of the unit, above the keyboard.

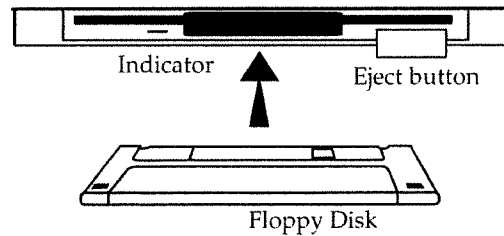

**NOTE** *Never attempt to remove a floppy disk from the drive while the drive is operating (the indicator is lit); damage could result to both the disk and the drive.*

- 2. Press the Eject button.**

The floppy disk is ejected a little out of the slot. Gently grasp the end of the floppy disk and pull it out.

### ■ Playing the Disk Rhythms

- 1. Press the Rhythm [Disk] button (confirm that its indicator is lit)**
- 2. Insert the Music Style disk into the disk drive.**
- 3. Use the [-] [+] Composer Select buttons to select a Rhythm on the Music Style disk.**

**NOTE** *The [Start/Stop] button indicator will be blinking while the Rhythm is being loaded. You can play the selected Rhythm after loading is completed.*

- 4. Press the [Start/Stop] button or the [Intro/Ending] button.**

The selected song is played.

### ■ Loading Disk Rhythms Into Internal Memory

The [Disk] button already contains 2 Rhythms, but these can be rewritten by Rhythms from a Music Style disk. Rhythms loaded from the disk into internal memory will not be lost even if the power is turned off. It is convenient to load frequently-used disk Rhythms into internal memory.

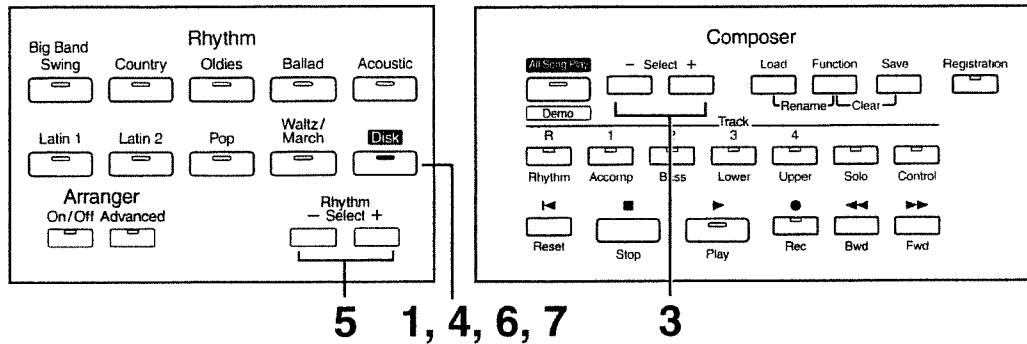

1. Press the Rhythm [Disk] button (indicator lights).
2. Insert the Music Style disk into the disk drive.
3. Use the [-] and [+] Composer Select buttons to select a disk Rhythm (indicator begins to flash).

```
BigBndBalld2 R01
J: 74 C Maj
```



Press the [Start/Stop] button, you can hear the Rhythm.

4. After selecting a disk Rhythm, press the Rhythm [Disk] button once more.

The following screen will appear.

```
To: Hawaiian
Write? +/-Disk
```

5. Use the [-] and [+] Rhythm Select buttons to select where you wish the selected Rhythm to be stored.

6. Press the Rhythm [Disk] button to confirm the storage-destination Rhythm.

```
Overwrite Style?  
Yes:Disk No:Exit
```

To cancel the procedure, press the [Display/Exit] button.

7. Press the Rhythm [Disk] button again to start loading the Rhythm into the internal memory.

While the Rhythm is being loaded into internal memory, the following screen will be displayed.

```
Overwriting  
Style...
```

Once the Rhythm has been accommodated in memory, the basic screen will reappear.



*Never remove the disk or turn off the power while the Rhythm data is being loaded from disk into the AT-20R. If you do so, the Rhythm data will not be loaded into the AT-20R, and malfunctions could result. After returning the Rhythm stored in the [Disk] button to the factory settings (see following section), re-load the Rhythm from disk.*

## ■ Restoring the Rhythm Stored in the [Disk] Button to the Factory Settings

The Rhythm that was loaded from the Music Style disk into the [Disk] button will not disappear even if you turn off the power or execute the Factory Reset operation. If you wish to restore the Rhythm of the [Disk] button to the factory setting, use the following procedure.

1. Press the [Power] button to turn off the power.
2. Hold down the Rhythm [Disk] button, and press the [Power] switch.

The Rhythm that had been stored in the Rhythm [Disk] button will return to the factory settings.



*To return settings other than those of the [Disk] button to the factory settings, use the Factory Reset operation (p. 16).*

# Adding Various Effects to a Voice

The AT-20R allows you to add a variety of effects to each voice, and to use various playing techniques to make your performance more expressive.

## Adding Harmony to a Melody — Harmony Intelligence

Harmony Intelligence is a function that adds harmony to a single note being played on the Upper keyboard, the harmony being dependent on the chord played on the Lower keyboard. In addition it automatically selects the appropriate voices according to the harmony type.

### 1. Press the [Harmony Intelligence] button (indicator lights).

Each time you press a [Harmony Intelligence] button, the indicator will alternate between ON (lit) and OFF.

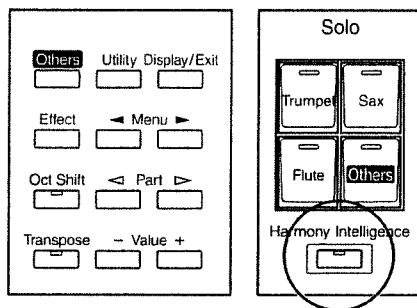

## Changing the Type of Harmony Intelligence

There are 4 different Harmony Intelligence.

When you press the [Harmony Intelligence] button, the most appropriate voice(s) will be automatically set.

The manner in which notes will sound also depends on the Harmony type.

1. Press the [Harmony Intelligence] button (indicator lights).
2. While the voice name is shown in the display screen, use the Value [-] [+] buttons to select the Harmony Intelligence.

The indicator of the [Harmony Intelligence] button will blink.

3. Once again, press the [Harmony Intelligence] button.

The indicator of the [Harmony Intelligence] button will light, and the Harmony Intelligence is confirmed.



*You may change the selected Solo voice and/or the Upper voice to one of your choice.*



How notes pressed are sounded by the different Harmony Intelligence types:

|                    | Type   | How notes pressed are sounded |
|--------------------|--------|-------------------------------|
| <b>Traditional</b> | Type A | Solo & Upper                  |
| <b>Harp</b>        | Type B | —                             |
| <b>Octave 1</b>    | Type A | Solo & Upper                  |
| <b>Octave 2</b>    | Type A | Solo & Upper                  |

### ○ How notes are sounded by the different Harmony Intelligence types

#### Type A (Solo & Upper)

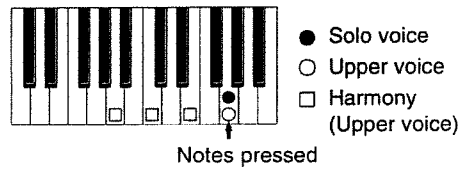

#### Type B

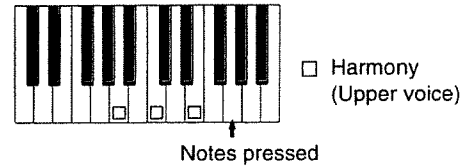

*The number of notes of the harmony will depend on the Harmony Intelligence type.*



*You can select the Harmony Intelligence at the Utility menu (p. 92).*

## Rotary Effect

---

Rotary is an effect which simulates the sound of rotating speakers. There is a choice of two settings: Fast and Slow.

The Rotary effect can be applied to the following sounds.

- Voices assigned to buttons in the upper line of "Upper Organ" and "Lower Organ."



*Some sounds do not allow the Rotary effect to be applied. For details refer to "Voice List" (p. 103).*

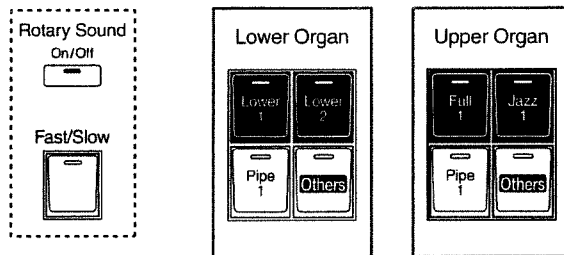

- 1. Select the voice to which you wish to apply the Rotary effect.**
- 2. Press the Rotary Sound [On/Off] button (confirm that its indicator is lit).**

The Rotary effect will be applied to the voice.

- 3. Press the Rotary Sound [Fast/Slow] button to switch between Rotary Fast (LED lit) and Rotary Slow (LED turned off).**

**LED lit (Fast)** The effect obtained is equivalent to speakers being rapidly rotated.

**LED turned off (Slow)** Effect simulating the slow rotation of speakers.



*You can assign the Rotary Sound [Fast/Slow] button function to the foot switch located on the left side of the Expression Pedal (p. 90).*

## Reverb Effect

Reverb is an effect that adds a sense of spaciousness to the sound, creating the illusion of playing in a large or small concert hall, a large or small room, a small club, etc.

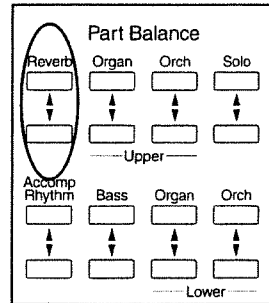

1. Press the Reverb [ ▲ ] or [ ▼ ] buttons in the far left side of the Part Balance section to adjust the overall Reverb amount.

When you press the up button [ ▲ ], additional Reverb is applied. Pressing the down button [ ▼ ] decreases the Reverb level.



You can also select the type of Reverb you wish and the level for each individual Part. For details refer to "Changing the Reverb Type" (p. 87) and "Changing the Reverb Depth" (p. 88).

## Sustain Effect

Sustain allows you to add a Sustain effect or decay to each voice after the keys are released. The Sustain effect can be added simultaneously to the Upper (except the Solo Part), Lower, and Pedal Bass voices.

1. Press the [Effect] button.
2. Use the [ ◀ ] and [ ▶ ] Menu button to select the "Sustain."
3. Use the [ ◀ ] and [ ▶ ] Part button to select the desire part.
4. Use the [-] and [+] Value buttons to switch ON or OFF.
5. To return to the basic screen, press the [Effect] or [Display/Exit] button.

The basic screen will reappear.



The length of Sustain can be modified independently for each keyboard (p. 88).

# Using the Play Functions

## Using the Lower Keyboard to Play the Bass Voice — [To Lower] Button

By using the [To Lower] button, you can sound the Pedal Bass voice by playing the root note (see p. 110) of a chord on the Lower keyboard in the area that is playing the Lower voice.



*If no portion of the Lower keyboard is sounding the Lower voice (the [Manual Drums] button is ON), the Pedal Bass voice will not sound.*

Pedal Bass



- 1. Select a Pedal Bass voice (p. 22).**
- 2. Press the [To Lower] button (indicator lit).**

When you play a chord in the area of the Lower keyboard that sounds the Lower voice, the Pedal Bass voice will also be heard and will play the root note.

Now when you play C/E/G on the Lower keyboard, the C (bottom note) will also play the Pedal Bass voice. In this way, the Pedal Bass voice will be played by the root note of the chord you play on the Lower keyboard.

If the Leading Bass function is assigned to the Foot Switch (p. 90), the lowest note you play in the Lower keyboard will sound the Pedal Bass voice.



*If the [To Lower] is ON, the Pedal Bass voice will not be heard from the Pedalboard.*

## Transposing to a Different Key (Transpose Button)

This function allows you to transpose the keyboard to another key in semitone steps. For example: you may play in the familiar C major scale while your music will sound in any key of your choice.

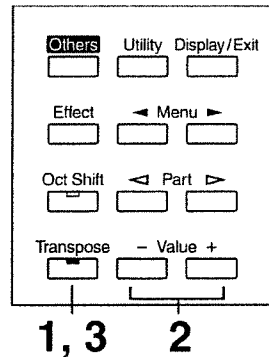

- 1.** Press the [Transpose] button (indicator will flash).
- 2.** Set the transpose value using the [-] and [+] Value buttons.

Each press of the [-] or [+] Value button transposes the key a semitone. Acceptable values range from A $\flat$  to G (in semitone steps).



By pressing the Value [-/+] buttons simultaneously, you can restore the default setting C.

- 3.** Press the [Transpose] button to return to the basic screen.

If the transpose function is set to any key other than C, the Transpose button indicator will be lit. If the pitch is not transposed (i.e., the key is C), the [Transpose] button indicator will be dark.



The transposition setting is stored in the Registration. For details on the settings that are stored in the Registration, refer to "Settings That Are Stored After the Power Is Turned Off" (p. 109).



You can change the timing at which the transposition settings saved in a Registration will be recalled. For details refer to "Registration Transpose Update (Transpose Setting Recall Timing)" (p. 93)

## Adjusting the Overall Volume Using an Expression Pedal

---

You can adjust the entire volume using an Expression Pedal. When you depress the Expression Pedal, the volume increases. The volume decreases as you tilt the pedal back.

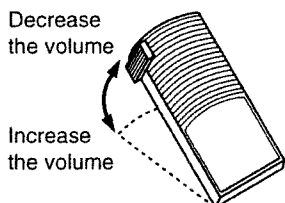

*You can also specify whether the Expression Pedal will or will not control the volume during the recording of music data (p. 79).*



*Likewise you can specify whether the Expression Pedal will or will not control the volume during the playback of recorded music data (p. 80).*



*The volume of a song file that has not been created on an Atelier (SMF Song Files) cannot be controlled from the Expression Pedal.*

## Adding Decay to the Sound (Damper Pedal)

---

When you depress the Damper (Sustain) pedal, a decay effect will be added to the voices. While you continue depressing the damper pedal, notes will be sustained even if you release the keys.

By default the decay effect will be applied to the voices played on the Lower keyboard.

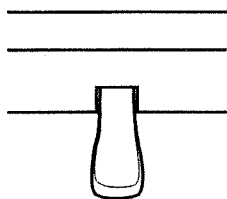

*You can modify the setting so that decay is applied to notes played on the Upper keyboard (p. 91).*



*Decay cannot be added to the Solo voices.*



*Decay can not be applied to Pedal Bass voices played on the Lower keyboard (when the [To Lower] button indicator is lit).*

---

## Using the Foot Switch

---

The instrument is provided with a Foot Switch, one on left side of the Expression Pedal. You can switch between Fast/Slow for the Rotary effect by pushing the left switch with your foot.

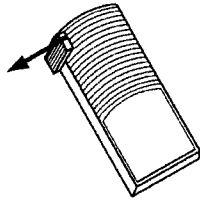

With the factory settings, the following function is assigned to the left Foot Switch.

**Left Foot Switch**      Switch the Rotary effect between Fast/Slow

### 1. Press the left Foot Switch toward the left.

The Rotary effect will switch between “Fast” and “Slow” each time you press the Foot Switch.



*You can also change the function assigned to the left Foot Switch. Please refer to “Left Foot Switch Assignment” (p. 90).*



*You can select the keyboard to which the effect will apply when you operate the Foot Switch. Please refer to “Glide Destination” (p. 91).*



*If the Utility menu item Registration Shift is ON, the left Foot Switch will be dedicated to switching through the Registration buttons (p. 90).*

# Using the Registration Buttons

The AT-20R allows you to store sound settings and panel settings such as 4 in the Registration buttons. There are a total of 4 Registration buttons, and one set of panel settings can be stored in each, allowing you to register a total of 4 different panel settings. Each set of panel settings that has been stored in a Registration button is called a "Registration."

This provides a convenient way to change large numbers of panel settings during a performance, or to recall a complex panel setting.

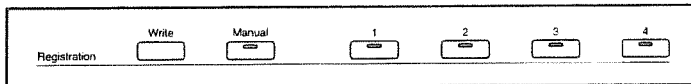

*Settings that have been stored to Registration buttons [1]–[4] are remembered even if the power is turned off. If you wish to restore the settings stored in the Registration buttons to their factory settings, use the "Factory Reset" operation (p. 16).*

## Storing Registrations

---

- 1. Make all the panel settings that you wish to store.**
- 2. While holding down the [Write] button, press one of the Registration buttons [1] – [4].**

The panel settings will be stored in the selected Registration button.



*With the settings of Registration buttons [1] – [4] considered as one set, a single floppy disk can store up to 99 sets of data (p. 53).*



*For details on the settings that are stored in a Registration, refer to "Settings That Are Stored in the Registration Buttons" (p. 109).*



## Recalling a Registration

### ■ How to Recall a Registration

#### ○ Recalling Voices and Other Panel Settings

1. Press a Registration button [1]–[4].

#### ○ Recalling Settings for Rhythm and Automatic Accompaniment in Addition to the Panel Settings

1. Press and hold a Registration button [1]–[4] for several seconds.

### ■ Changing the Timing of Recalling Registrations

Settings for Rhythm play and Automatic Accompaniment are recalled when you continue holding a Registration button [1]–[4] for several seconds, but you can change this so that the settings are recalled the instant you press the button.

1. Press the [Utility] button located to the left of the display.
2. Use the [◀] and [▶] Menu buttons to select the “Arranger Update.”

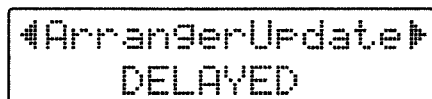

3. Press the [-] and [+] Value buttons to switch between “DELAYED” and “INSTANT.”

To return to the basic screen, press the [Utility] or [Display/Exit] button.

---

**DELAYED** When you press and hold a Registration button [1]–[4] for several seconds, the settings for Rhythm and Automatic Accompaniment will be recalled in addition to the panel settings. If you press and immediately release a Registration button [1]–[4], only the settings that are not related to Rhythm or Automatic Accompaniment will be recalled.

---

**INSTANT** Settings for Rhythm and Automatic Accompaniment will be recalled the instant that you press a Registration button [1]–[4].

---



*You can change the timing of recalling the transpose setting when you press a Registration button [1]–[4]. For more information, please refer to p. 93.*

## Automatically Registering When You Switch Panel Settings

When the [Manual] button is ON (lit), all panel settings you make will be stored automatically in the [Manual] button as they are made, thus updating the Registration that had been previously saved. If you change to a preset Registration [1]–[4], it is possible to return to the previous panel settings by pressing the [Manual] button.

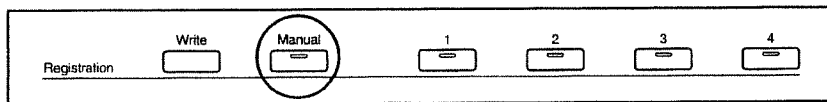

*The settings stored in the [Manual] button returns to the default settings while the power is turned off.*

## Assigning a Name to a Registration Set

When saving Registration sets, names like “REGIST-01 – 99” will be assigned by default, but you can assign a name that will help you later to identify the contents of the Registration set.

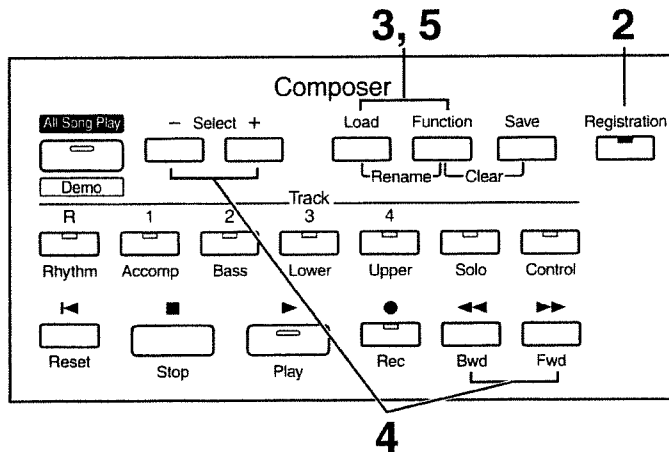

- 1.** Make sure that the disk drive contains a disk that was formatted (p. 64) by the AT-20R.
- 2.** Press the [Registration] button (indicator lights).
- 3.** Press the [Load] button and the [Function] button simultaneously.

- 4.** Use the [-] and [+] Composer Select buttons to move the cursor, and use the [Bwd]/[Fwd] buttons to select a character.

```
REGIST-01  ----
Mem: █
```

The following characters can be selected.

space ! " # % & ' ( ) \* + , - . / : ; = ? ^ \_ A B C D E F G H I J K L M N O P Q R S T U V W X  
Y Z a b c d e f g h i j k l m n o p q r s t u v w x y z 0 1 2 3 4 5 6 7 8 9

You can also use the [Reset] button to delete a character, and the [Rec] button to insert a space.

- 5.** When you have finished assigning the name, simultaneously press the [Load] button and the [Function] button once again.

The Registration set in the AT-20R's internal memory has now been named.

```
REGIST-01  ---
Mem: My Regist
```

To return to the basic screen, press the [Registration] button or the [Display/Exit] button.



*It is not possible to save during the process of assigning a name.*

### ■ Copying Only the Name of a Registration

Here's how you can copy just the name of a Registration without copying its performance data.

- 1.** Insert the floppy disk that contains the Registration that you wish to copy into the disk drive.
- 2.** Press the [Registration] button to make the indicator light.
- 3.** Use the Composer Select [-] and [+] buttons to select the Registration whose name you wish to copy.
- 4.** Simultaneously press the [Load] button and [Function] button.

```
My Regist      USE  
Mem:
```

- 5.** Press the [Load] button.  
Only the name of the Registration will be recalled.

```
My Regist      USE  
Mem:My Regist
```

- 6.** Simultaneously press the [Load] button and [Function] button.

## Saving Registration Sets to a Floppy Disk (Save Button)

With the settings of Registration buttons [1] – [4] considered as one set, a single floppy disk can store up to 99 sets of data. We recommend that complex panel settings or Registrations you wish to keep be saved on disk. If AT-20R Registrations that you create are saved on a floppy disk, they can then be recalled later or recalled for use on another AT-20R.

- 1. Make sure that the disk drive contains a disk that was formatted by the AT-20R.**
- 2. If the [Registration] button indicator is not lit, press the [Registration] button (indicator lights).**
- 3. Use the [-] and [+] Composer Select buttons to select the number that you wish to save to.**

Numbers which have not been used in the Saving operation will be displayed as “---”.

```
REGIST-01    ----
Mem:My Regist
```

To cancel the operation, press the [Registration] button.

- 4. Press the [Save] button to execute the save operation.**

When the Registration set is saved to the floppy disk, the indication of “---” will change to “USE.”

```
My Regist    USE
Mem:My Regist
```

When saving is completed, the basic screen will reappear.

If you have assigned a name, the Registration set will be saved to floppy disk with that name.

### ● If the Following Screen Appears

If you press the [Save] button for a Registration number with the word “USE” indicated, the following message will appear.

```
OverwriteRegist?
Yes:REC No:RST
```

### ○ If you wish to update the contents of the Registration data

- 1. Press the [Rec] button.**

The Registration will be rewritten.

- **If you wish to save the data without erasing the Registration set already on disk**

**1. Press the [Reset] button to cancel the procedure.**

Rewriting of the Registration will be canceled.

**2. Use the [-] and [+] Composer Select buttons to select a number for which "--" is displayed on the upper right of the screen.**

**3. Press the [Save] button to save the Registration set.**

When the data has been saved, the basic display will reappear.

When the Registration set is saved to the floppy disk, the indication of "---" will change to "USE."

## Loading Previously Saved Registration Sets Into the AT-20R (Load Button)

---

Here's how to recall a previously saved Registration set from the floppy disk into the memory of the AT-20R.

Registrations can be selected in the following two ways.

- **Loading a Set of Registrations**

You can load a "set" (a collection of settings for Registration buttons [1] – [4]) from floppy disk.

- **Loading an Individual Registration**

You can load settings for an individual Registration button [1] – [4].



*Be aware that when you load Registrations from a disk, the Registrations that were previously in internal memory will be lost. It is a good idea to save important Registrations to floppy disk (see p. 53).*

### ■ Loading a Set of Registrations

Registrations Sets saved to a floppy disk can be loaded back into the instrument.

- 1. Insert the floppy disk into the disk drive.**
- 2. Press the [Registration] button (indicator lights).**
- 3. Use the [-] and [+] Composer Select buttons to select the Registration set that you wish to load.**

```
My Regist      USE
Men#
```

To cancel the procedure, press the [Registration] button.

**4. Press the [Load] button to execute loading.**

When loading is complete, the basic screen will reappear.

## ■ Loading an Individual Registration

You can load any desired individual Registration to any desired Registration button.

- 1.** Insert the floppy disk containing the Registration into the disk drive.
- 2.** Press the [Registration] button (indicator lights).
- 3.** Use the [-] and [+] Composer Select buttons to select the Registration set that you wish to load.
- 4.** Press the [Function] button.
- 5.** Use the [Bwd]/[Fwd] buttons to specify the Registration button number to be loaded.

```
Load One Regist  
from: 1  </>/REC
```

- 6.** Press the [Rec] button.
- 7.** Use the [Bwd] or [Fwd] buttons to specify the storage-destination Registration.

```
Load One Regist  
to: 1  </>/REC
```

- 8.** Press the [Rec] button.

The following display will appear.

```
Load Sure?  
Yes:REC No:RST
```

To cancel the procedure, press the [Reset] button.

- 9.** Press the [Rec] button once again.

When the Registration has been loaded, the basic screen will reappear.

## Deleting a Previously Saved Registration Set

---

Here's how to delete a Registration set that was saved to a floppy disk.

- 1. Insert the floppy disk into the disk drive.**
- 2. Press the [Registration] button (indicator lights).**
- 3. Use the Composer Select [-] and [+] buttons to select the Registration set that you wish to delete.**
- 4. Simultaneously press the [Function] button and the [Save] button.**

The following display will appear.

```
Delete Regist?  
Yes:REC No:RST
```

To cancel the operation, press the [Reset] button.

- 5. If you are sure that you wish to delete the data, press the [Rec] button.**

When the Registration has been deleted, the basic screen will reappear.

When a Registration set has been deleted, the indication of "USE" will change back to "--". If you had assigned a name to the Registration set you deleted, the name will revert back to "REGIST-XX."

```
REGIST-01  ----  
Men:
```



# Record and Playback Your Performance

The AT-20R's Composer allows you to record (in digital form) what you played on the instrument.

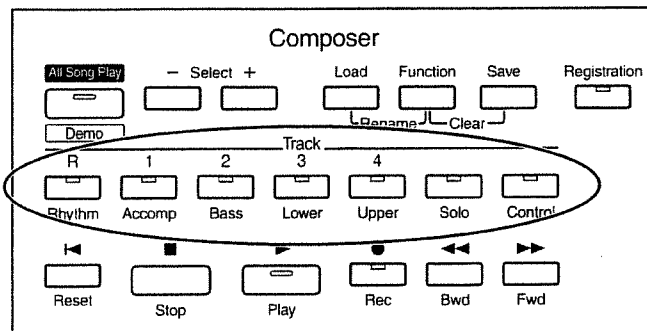

## What is a Track?

The Composer operates like a tape recorder with the capability of recording seven separate tracks. You can record different kinds of performance data into each track:

- Rhythm** Rhythm performances, Manual Drums
- Accomp** Automatic Accompaniment (except Bass)
- Bass** Pedal Bass voice, Bass part of the Automatic Accompaniment
- Lower** Lower voice
- Upper** Upper voice
- Solo** Solo voice
- Control** Panel operations, Expression Pedal operations



*More information about the track assignments when playing commercial SMF data, please refer to page 61.*

During recording, the control track will store the operations as follows.

### ○ Panel Operations

(Voice selections, Tempo changes, Rotary fast/slow etc.)

Newly recorded performance data will be added without erasing the previously recorded data.

If you wish to erase all the recorded data and record new performance data, use the editing function "Erase" (erase performance data) to erase the data (p. 84).

### ○ Expression Pedal Operations

This will depend on the expression function in the Function menu. The way in which expression operations are recorded will depend on the setting of the "Exp. Source" item "Recording" in the Function menu.

- PEDAL** Expression pedal operations will be recorded.  
If expression data has already been recorded, the previously recorded data will be erased as the new data is recorded.
- COMPOSER** Expression pedal operations will not be recorded.  
If expression data has already been recorded, the previously recorded data will remain without being erased.

For details refer to "How the Expression Pedal Functions (Exp. Source)" (p. 79).

## Recording Performances (Rec Button)

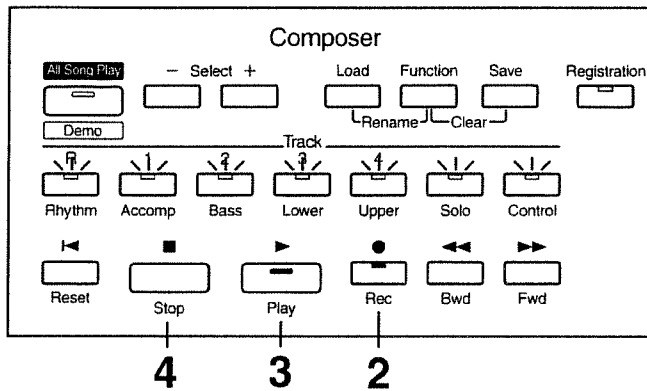

**1. Select the panel settings needed for recording the performance.**

If a floppy disk is in the disk drive, press the Eject button (p. 37) and remove the floppy disk.

**2. Enter the recording standby mode by pressing the [Rec] button.**

The [Rec] button's indicator will light. The [Play] button and all track indicators will flash.

**3. Press the [Play] button to start recording.**

When you press the [Play] button, the metronome will play two measures (bars) of count-in before recording begins.

If you wish to use Rhythm and Automatic Accompaniment as you record, press the [Start/Stop] button instead of the [Play] button to begin recording. Also, if the [Sync] button is lit (i.e., if Sync Start is ON), recording will begin the instant you play the Lower keyboard.

**4. Press the [Stop] button when you have completed your recording.**

The Track indicator where a performance song is recorded will change from a flashing to a constant light.

If you press the [Reset] button instead of the [Stop] button, the unit resets (returns) to the beginning of the song just recorded.



When you press the [Intro/Ending] button (or [Start/Stop] button) while recording a Rhythm performance or Automatic Accompaniment, the Rhythm performance and Automatic Accompaniment will stop. However, the recording itself will continue. Press the [Stop] button to stop recording.



The Play and Stop functions can both be assigned to the foot switch located on right side of the Expression Pedal. Each touch of the switch will alternate the operation between the Play and Stop functions (p. 90).



You can also choose to cancel the metronome count-in before recording starts (p. 78).



If you press the [Rec] button when a song has been selected from the floppy disk, the selected song will be completely loaded into the AT-20R and the Composer will enter into the recording standby mode.

If you wish to record a new song, use the [-] and [+] Composer Select buttons to first select "NEW SONG" before pressing the [Rec] button. Alternatively, eject the disk from the floppy disk drive before pressing the [Rec] button.

```
NEW SONG 1
♩:120
```

### ● If the Following Screen Appears

```
Internal Memory
Near Limit
```

When the instrument's memory is nearing capacity.

```
Memory Full
```

When recording was automatically canceled because the memory limit was reached.

## Recording Each Part Separately

---

As you listen to the recorded performance, you can record each Part in sequence. In this method, each part is recorded one after another: first the Rhythm part, then the bass part, etc. If there are any previously recorded performances, you can listen to them as you record additional parts.

- 1. Select the panel settings needed for recording the performance.**
- 2. Use the [Bwd] / [Fwd] buttons to select the desired measure (bar) when you start recording.**

If you wish to start recording from the beginning of the song, press the [Reset] button.

- 3. Press the [Rec] button to enter the recording standby mode.**

The [Rec] button indicator will light, and the [Play] button and the track buttons of un-recorded tracks will blink.

The button indicators of tracks that are already recorded will light.

- 4. Press the [Play] button to start recording.**

When you press the [Play] button, the metronome will play two measures (bars) of count-in before recording begins. As you listen to the performance song previously recorded, record the Part into a new Track.

- 5. Press the [Stop] button when your recording is completed.**

The track button indicators for which performance data has been recorded will be lit.

## Playing Back a Performance Song (Play Button)

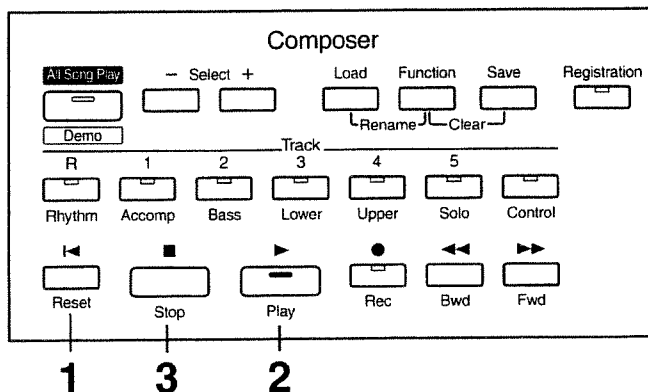

**1. Press the [Reset] button to return to the beginning of the first measure (bar).**

The location at which playback will start will return to the beginning of measure 1. When you wish to play a performance song from a specific point, use the [Bwd] / [Fwd] buttons to select the desired measure (bar).

**2. Press the [Play] button to start playback.**

After playback reaches the end of the performance, it will stop automatically.

**3. To stop playback at any point, press the [Stop] button.**

If you press the [Reset] button instead of the [Stop] button, the unit resets (returns) to the beginning of the data.



*If you press the [Play] button while holding down the [Stop] button, the metronome will play two measures (bars) of count-in before playback starts.*



*The [Play] and [Stop] functions can be assigned to the foot switch located on left side of the Expression Pedal. Each touch of the switch will alternate the operation between the Play and Stop functions (p. 90).*



*You can specify whether or not the Expression Pedal will affect the playback and what you play while Atelier music data is being played back (p. 80).*



*If you use the Rhythm or Automatic Accompaniment immediately after having loaded and played back a song other than an Atelier performance song, such as SMF's, etc., the playback may not sound right (the voices may have changed, etc.) To prevent this from happening, press the [Reset] button before playback.*



*When a song other than an Atelier performance song (such as an SMF Song File) is loaded and played back, the Expression Pedal will have no effect on the playback volume.*

## Silencing a Specific Track — Track Mute

The button indicators for tracks in which performances were recorded will be lit. By turning off these track button indicators, you can temporarily silence the sound. This is referred to as “Track Mute.”

### Example: Muting the sound for Upper Part

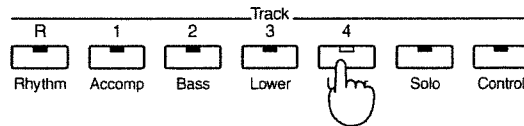

#### 1. Press a track button whose indicator is lit to turn the light off.

The track whose indicator was turned off will be muted (silenced).

#### 2. Press the track button once again (indicator lights).

The part that had been muted will return to normal and will be heard.

### ■ Track Assignments When Playing Commercial SMF Data

- When you playback without loading (p. 70, p. 72) the SMF data

| Button | Channel                               |
|--------|---------------------------------------|
| [R]    | 10                                    |
| [1]    | 1                                     |
| [2]    | 2                                     |
| [3]    | 3                                     |
| [4]    | 4                                     |
| [Solo] | 5, 6, 7, 8, 9, 11, 12, 13, 14, 15, 16 |

- When you first load and then playback the SMF data

| Button | Channel                                                            |
|--------|--------------------------------------------------------------------|
| [R]    | 10                                                                 |
| [1]    | Performance data other than 2 and 10                               |
| [2]    | 2                                                                  |
| [3]    | Nothing (Performance data from the ATELIER series can be recorded) |
| [4]    | Nothing (Performance data from the ATELIER series can be recorded) |
| [Solo] | Nothing (Performance data from the ATELIER series can be recorded) |

## Re-Recording

If you made a mistake in your performance during recording, you can re-record just a portion of the musical data in the track.



*If you wish to re-record with different settings for voices, tempo, part balance, erase the recorded song (p. 63) and re-record again. If the Control track still contains data from before you re-recorded, the volume or sounds may change during playback.*

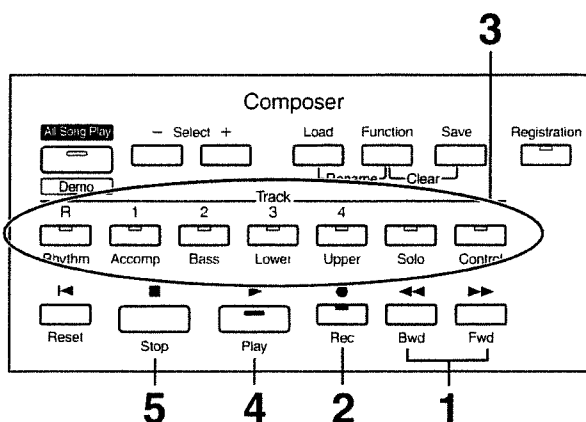

**1.** Use the [Reset] button or the [Bwd] / [Fwd] buttons to move to the measure (bar) where you wish to start re-recording.

**2.** Press the [Rec] button to enter into the recording standby mode.

The [Rec] button indicator will light, and the indicators of the [Play] button and the track buttons of unrecorded tracks will flash. The track buttons of tracks already-recorded will light.

**3.** Press the Track button which you wish to re-recording (indicator flashes).

The song data of the specified Track (with the exception of the Control Track) will be erased as new song data is recorded.

When the indicator of a Track is lit constantly, no song data has been recorded on that Track.

**4.** Press the [Play] button to start recording.

When you press the [Play] button, the metronome will play two measures (bars) of count-in before recording begins.

**5.** Press the [Stop] button when your recording is completed.

The button indicators of tracks which were re-recorded will change from flashing to being constantly lit.



*If you wish to keep the existing Expression Pedal data, and record only the panel operations, you can make settings to prevent the operation of the Expression Pedal from being recorded (p. 79).*



*You can use punch-in recording (p. 74) to re-record only the area that you specify.*

## Erasing a Performance Song (Clear)

If you wish to discard your recording and re-record from the beginning, or if you wish to record a new performance, you must erase the previously-recorded data.

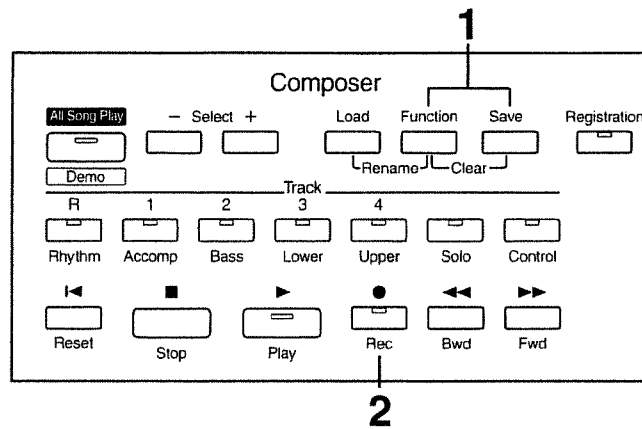

- 1. Press the [Function] and [Save] buttons simultaneously.**

The following message, asking you to confirm your choice, will be displayed.

```

Clear Song Sure?
Yes:REC No:RST
    
```

To cancel the procedure, press the [Reset] button.

- 2. If you are sure that you wish to erase the song, press the [Rec] button.**

## Formatting Disks

Before any floppy disk (new or used) can be used with the AT-20R, it must first be formatted (prepared).

Floppy disks must first be "formatted" (initialized) before they can be used by the AT-20R to store data. "Formatting" is the process of erasing any data which may have been on the disk and making the format of the floppy disk match the format of the device. The AT-20R cannot use a floppy disk that has a format differing from its own format.



*Formatting a disk will erase any data that may have been stored on it. Carefully check any previously used disk to be sure it doesn't contain any valuable data.*

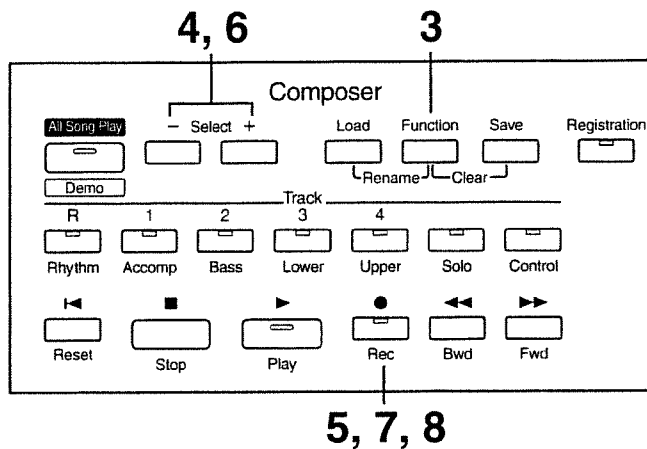

1. Make sure that the write protect tab of the floppy disk is in the "Write" (permit) position.

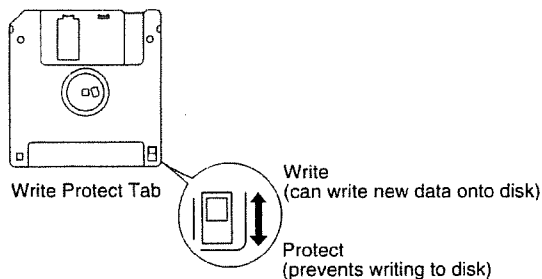

2. With the label of the floppy disk facing upward, insert it into the disk drive until it clicks into position.

The disk drive is located to the upper right of the AT-20R's keyboard.



*Please DO NOT insert the floppy disk into the gap between the cabinet and the lid.*

3. Press the [Function] button.



- 4.** Use the [-] and [+] Composer Select buttons to select “Disk Utility.”

```
Disk Utility 
Yes:REC
```

- 5.** Press the [Rec] button.

- 6.** Use the [-] and [+] Composer Select buttons to select “Format Disk.”

- 7.** Press the [Rec] button.

The following message, asking you to confirm, will be displayed.

```
Format Sure?
Yes:REC No:RST
```

To cancel the procedure, press the [Reset] button.

- 8.** Press the [Rec] button again to perform the Format.

While formatting is in progress, the following display will appear.

```
Formatting
25% 00.....
```

When formatting is completed, the basic screen will reappear.



*Never attempt to remove the floppy disk until formatting is complete.*

## Changing the Name of a Performance Song (Rename)

A name is automatically assigned to a performance song that you record. However, at some point you may wish to change the name to something more meaningful.

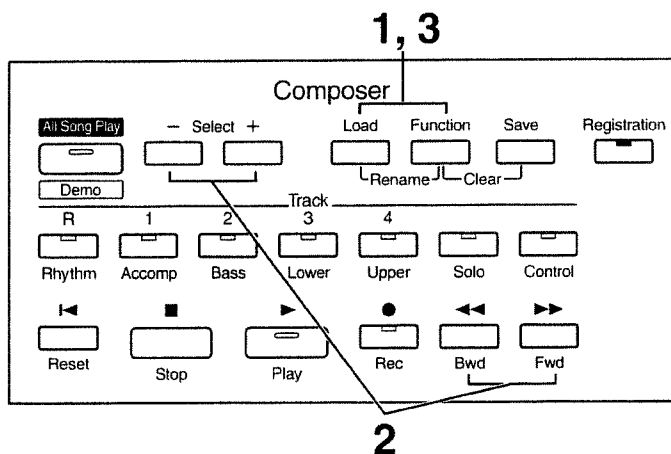

1. Press the [Load] and [Function] buttons simultaneously.
2. Use the [-] and [+] Composer Select buttons to move the cursor, and use the [Bwd]/[Fwd] buttons to select a character.

The following characters can be selected when changing a name:

space! " # % & ' ( ) \* + , - . / : ; = ? ^ \_ A B C D E F G H I J K L M N O P Q R S T U V W X Y Z  
a b c d e f g h i j k l m n o p q r s t u v w x y z 0 1 2 3 4 5 6 7 8 9

To delete a character, press the [Reset] button. A space can be inserted by pressing the [Rec] button.

3. To confirm the new name, simultaneously press the [Load] and [Function] buttons once again.

The new name is now inserted.

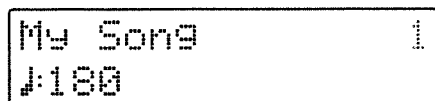

**NOTE**

*It is not possible to save during the Rename procedure.*

**NOTE**

*You cannot directly change or edit the name of a performance song stored on a disk. The song must first be loaded (p. 70) into the instrument, edited, and then saved to disk again.*

## Saving Performance Songs Onto Floppy Disk (Save Button)

The performance data that you recorded will disappear when the power of the AT-20R is turned off. If you wish to keep the performance data, you can save it on a floppy disk. If the performance data has never been saved to a floppy disk, a "☐" symbol will appear in the display. When the performance data is saved to a floppy disk, this symbol will no longer be displayed.

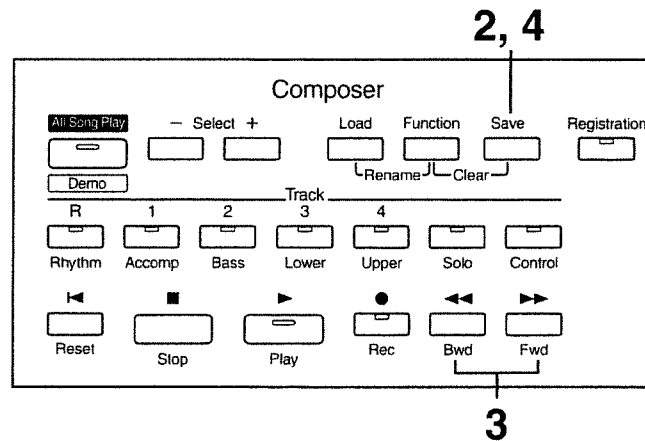
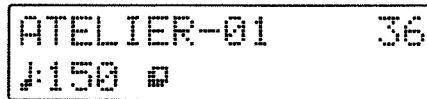

1. Insert a floppy disk formatted (p. 64) on the AT-20R into the disk drive.
2. Press the [Save] button to save the performance.
3. Use the [Bwd] / [Fwd] button to select the format.

You can select either "ORIGINAL" or "SMF" format.

**ORIGINAL**      Save data in Atelier format  
**SMF**              Save data in SMF format

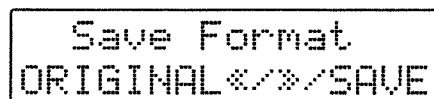

## Record and Playback Your Performance

---

### 4. Press the [Save] button to confirm the type of format.

While performance data is being saved to the floppy disk, the following display will appear.

```
ATELIER-01  36
Saving...
```



*Music data that was saved in Atelier format cannot be played back correctly on instruments other than the Atelier series.*



*For a detailed explanation of the SMF format, refer to "Saving in SMF Format" (p. 69).*

### ● If the Following Screen will Appear

If the floppy disk already contains performance data of the same name, the following display will appear.

```
Overwrite Song ?
Yes:REC No:RST
```

#### ○ If you wish to update the contents of the performance data

1. Press the [Rec] button.

#### ○ If you wish to save the data without erasing the performance data already on floppy disk you must rename the song

1. Press the [Reset] button to cancel saving.
2. Change the name (p. 66), and perform the Save procedure once again.

## ■ Saving in SMF Format

Since the AT-20R allows you to save data in SMF format, performance data you've recorded using the Atelier's organ sound generator can easily be edited on an external sequencer.

Alternatively, since the sound generator of the Atelier organ can be controlled from MIDI In, data that was saved in SMF format can be played back on your external sequencer, thus playing the Atelier via MIDI.



*SMF (Standard MIDI File) is a data format that was created as a standardized way to exchange music data between devices made by different manufacturers.*

- 1. Insert a floppy disk that was formatted by the AT-20R (p. 64) into the floppy disk drive.**
- 2. Press the [Save] button.**
- 3. Use the [Bwd] / [Fwd] buttons to select "SMF" as the format.**

```

Save Format
SMF  ⌘/⌘/SAVE
    
```

- 4. Press the [Save] button to confirm the type of format.**

The data will be saved in SMF format.

Performance data that was saved in SMF format will be indicated by a "⌘:" symbol.

```

My Song      *  1
⌘:180
    
```



*Saving performance data in SMF format (SMF) requires a longer time than saving it in Atelier format (ORIGINAL).*



*Performance data saved by the AT-20R will not playback correctly on any device other than the Atelier series.*

## Loading Performance Songs Into the AT-20R

To edit (p. 82) or re-record a performance song that is stored on a floppy disk, you must first load that song into the instrument.

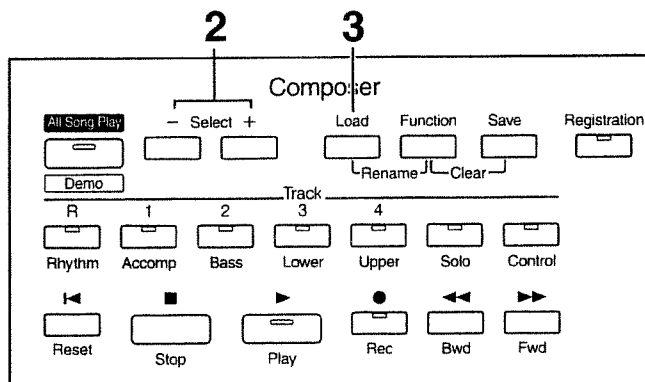

- 1.** Insert the correct disk into the disk drive.
- 2.** Press the [-] or [+] Composer Select button to select the performance song you wish to load.
- 3.** Press the [Load] button to carry out the load operation.

### ● If the Following Screen will Appear

The following message below is shown when the performance song in the unit has not been saved to floppy disk.

```
Clear Song Sure?  
Yes:REC No:RST
```

#### ○ If you wish to erase the performance song

- 1.** Press the [Rec] button.
- #### ○ If you wish to save the performance song on a floppy disk
- 1.** Press the [Reset] button to cancel the procedure.
  - 2.** Save the song onto a floppy disk (p. 67).



If you load a song other than Atelier performance songs (SMF song files, etc.), the Rhythm (drum) Part will automatically be loaded into the Rhythm track, and the other Parts loaded into the Accompaniment and Bass tracks.



If loading is canceled because the memory limit has been reached, the following message will be displayed:

Memory Full

### ■ Layering a New Recording onto SMF Format Music Data

You can load SMF format music data into the AT-20R and play it back while you record your own playing as an additional layer.

- 1. Insert a floppy disk containing SMF format music data into the floppy disk drive.**
- 2. Use the Composer select [-] [+] buttons to select the music data that you wish to load into the AT-20R.**
- 3. Press the [Load] button.**

The selected music data will be loaded.

When SMF format music data is loaded into the AT-20R, it will be stored in the following tracks (p. 61).

**Rhythm** The Rhythm performance (channel 10)

**Bass** The Bass performance (channel 2)

**Accomp** Performance data other than the Rhythm and Bass (except channels 2 and 10)

- 4. Make the panel settings that you wish to record.**
- 5. Use the [Bwd] button and [Fwd] button to move to the measure at which you wish to begin recording.**
- 6. Press the [Rec] button to enter record-ready mode.**

The [Rec] button indicator will light, and the [Play] button indicator will blink.
- 7. Press the [Play] button to begin recording.**

As you record, the music data that was loaded into the AT-20R will play back.
- 8. Press the [Stop] button to stop recording.**



The performance data you recorded can be saved on a floppy disk (p. 67).



Commercially sold music files can also be loaded into the AT-20R, but for reasons of copyright protection, cannot be saved in SMF format.

# Playing Back Performance Songs Stored on Floppy Disk

In addition to playing back the music you recorded on the instrument and saved to a floppy disk, AT-20R also lets you enjoy a wide variety of commercially available song files, such as defined below.

## SMF Song Files

The Standard MIDI File (SMF) format was designed to provide a means for exchanging performance data among a wide variety of devices. In addition to the song files described earlier, the AT-20R is also capable of playing back any Standard MIDI File compatible with the GM or GS formats.



*If you wish to purchase SMF music data, please contact the dealer where you purchased the AT-20R.*

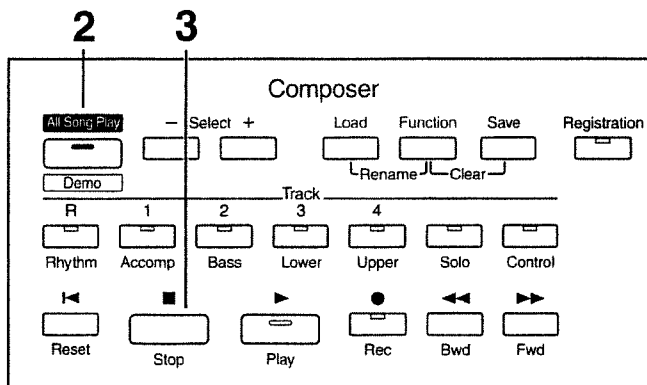

**1. Insert the correct floppy disk into the disk drive.**

When the performance song loaded from a disk is a Standard MIDI File, "♩:" will be displayed after the file name.

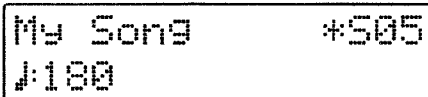

**2. When you wish to play back all the performance songs in order, press the [All Song Play/Demo] button.**



*When you only wish to play back one song, use the [-] and [+] Composer Select buttons to select the song, then press the [Play] button.*

**3. To stop playback, press the [Stop] button.**



---

## Erasing Performance Songs Stored on Disk

---

Follow the steps below to erase a performance song that was saved onto a floppy disk.

- 1. Insert the floppy disk into the disk drive.**
- 2. Press the [Function] button.**
- 3. Press the [-] or [+] Composer Select button to select “Disk Utility.”**

```
Disk Utility 
Yes:REC
```

- 4. Press the [Rec] button.**
- 5. Press the [-] or [+] Composer Select button to select “Delete Song.”**

```
 Delete Song
Yes:REC No:RST
```

- 6. Press the [Rec] button.**  
To cancel the procedure, press the [Reset] button.
- 7. Using the [Bwd]/[Fwd] buttons, select the performance song to be erased.**

- 8. Press the [Rec] button.**

You will see the following:

```
ATELIER-01  S01
Del Sure?REC/RST
```

- 9. To go ahead with the erasure, press the [Rec] button again.**

To cancel the procedure, press the [Reset] button.

When erasing is completed, the basic screen will reappear.

## Re-Recording Part of Your Performance — Punch-in Recording

---

After you have recorded a performance, you can re-record a specified portion of the performance. With this method, you listen to the recorded performance, and re-record just the desired area. This recording method is called “Punch-in Recording.”

### To use Punch-in Recording, you can...

- Turn on the Function menu item “Punch In/Out,” and specify the area that you wish to re-record.
- ↓
- Use the Composer to play back the recorded performance, and re-record just a specific portion.

### ○ Specify the Area that You Wish to Re-record

- 1.** Press the [Function] button.
- 2.** Use the [-] and [+] Composer Select buttons to select “Punch In/Out.”

```
▣ Punch In/Out ▣  
Yes: REC
```

- 3.** Press the [Rec] button.
- 4.** Use the [Bwd] / [Fwd] buttons to select “ON.”

```
Punch In/Out  
ON  ⏪/⏩/REC
```

ON      Punch-in Recording  
OFF     Normal Recording

- 5.** Press the [Rec] button.
- 6.** Use the [Bwd] / [Fwd] buttons to select “from” (the first measure that you wish to re-record).

```
Punch I/O Meas.  
from: 2 ⏪/⏩/REC
```

7. Press the [Rec] button.
8. Use the [Bwd] / [Fwd] buttons to select “for” (the number of measures that you wish to re-record).

Punch I/O Meas.  
for: 4 «/»

9. Press the [Function] or [Display/Exit] button.

○ **Re-record While You Listen to the Song**

10. Enter the recording standby mode by pressing the [Rec] button.

11. Press the Track button which you wish to re-recording (indicator flashes).

12. Press the [Play] button.

When you press the [Play] button, the metronome will play two measures (bars) of count-in before recording begins.

When you reach the first measure of the specified area, recording will begin. When the specified area ends, recording will end, and playback will resume.

- While the song is playing back or recording, the [Rec] button’s indicator will be lit as follows.
 

|                                       |                                                    |
|---------------------------------------|----------------------------------------------------|
| While the performance is playing back | The [Rec] button’s indicator will flash            |
| While you are re-recording            | The [Rec] button’s indicator will light constantly |



*When recording has ended for the specified area and the data is once again playing back, the [Rec] button’s indicator will resume flashing.*

13. Press the [Stop] button to stop the song.

The indicator of the track button which recorded the performance will light.



*When Punch-in Recording ends, the Function menu item “Punch In/Out” will return to OFF (normal recording). If you wish to use punch-in recording once again, you must make the “Punch In/Out” setting once again.*

## Repeatedly Layering Performances Over a Region — Loop Recording

You can repeatedly record over a specified area to build up multiple performances. This type of recording is called “Loop Recording.”

This recording method is convenient when you wish to layer drum sounds individually for the Rhythm part.



“Loop Recording” can be used only when recording the Rhythm part.

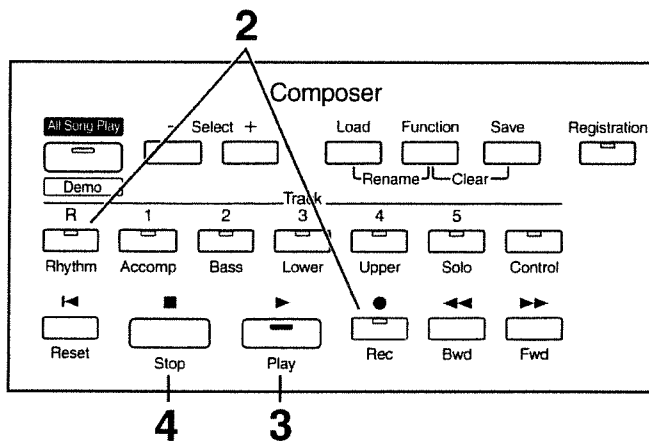

- 1.** Press the [Manual Drums] button to select a Drum Set or Sound Effect Set (p. 28).
- 2.** Enter the recording standby mode by pressing the [Rec] button and [Rhythm] button.

The [Play] button and [Rhythm] button indicators will flash.

- 3.** Press the [Play] button.

When you press the [Play] button, the metronome will play two measures (bars) of count-in before recording begins.

When recording reaches the end of the measure, it will return to the beginning of the measure, allowing you to continue recording to layer additional notes.



You can change the number of measures over which Loop Recording will occur. Please refer to “Changing the Number of Measures for Loop Recording” (p. 77).

- 4.** Press the [Stop] button to stop recording.

### ○ Changing the Number of Measures for Loop Recording

With the initial settings, Loop Recording will occur over one measure. In the Function menu you can change the number of measures over which Loop Recording will occur.

- 1. Press the [Function] button.**
- 2. Use the [-] and [+] Composer Select buttons to select “Loop Recording.”**



The Number of Measures for Loop Recording

- 3. Use the [Bwd] button and [Fwd] button to select the number of measures for Loop Recording.**
- 4. Press the [Function] or [Display/Exit] button.**

The number of measures for Loop Recording has now been specified.

Use the procedure for Loop Recording to begin recording.

# Settings for the Composer (Function Button)

## Count-in Recording

This setting (ON/OFF) determines whether or not a metronome count-in (2 measures) will be heard after pressing the [Play] button on recording. (The count-in helps you to establish the tempo before you begin playing.)

1. Press the [Function] button.
2. Using the [-] and [+] Composer Select buttons, select "Count-In Rec."

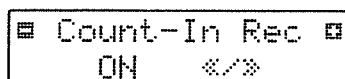

Count-In Rec  
ON

3. Use the [Bwd]/[Fwd] buttons to turn it ON or OFF.

ON A two-measure count will sound before recording  
OFF No count will sound before recording

To return to the basic screen, press the [Function] button or the [Display/Exit] button.

## Changing the Metronome Setting

This setting determines whether or not the metronome will sound.

1. Press the [Function] button.
2. Using the [-] and [+] Composer Select buttons, select "Metronome"

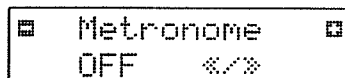

Metronome  
OFF

3. Use the [Bwd]/[Fwd] buttons to select OFF, REC, or ON.

OFF Not heard at all  
REC Heard only while recording  
ON Heard constantly

To return to the basic screen, press the [Function] button or the [Display/Exit] button.

## Metronome Volume

Carry out the steps below to adjust the volume of the metronome.

1. Press the [Function] button.
2. Using the [-] and [+] Composer Select buttons, select "Metronome Vol."

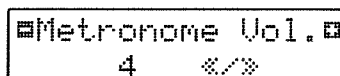

Metronome Vol.  
4

3. Press the [Bwd]/[Fwd] buttons to select the desired volume level (1–10).

Increasing the value will raise the volume of the metronome.

To return to the basic screen, press the [Function] button or the [Display/Exit] button.

## Changing the Sound of the Metronome

You can choose one of 4 different sounds for the metronome.

1. Press the [Function] button.
2. Use the [-] and [+] Composer Select buttons to select "Metronome Sound."

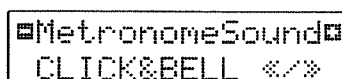

MetronomeSound  
CLICK&BELL

3. Press the [Bwd] / [Fwd] buttons to select the type of sound for the metronome.

CLICK&BELL Conventional metronome sound  
ELECTRONIC Electronic metronome sound  
VOICE ENG. Human voice (English)  
VOICE JPN. Human voice (Japanese)

To return to the basic screen, press the [Function] button or the [Display/Exit] button.

→ This setting remains stored in memory even while power is turned off.

## Setting the Beat

This setting determines the beat to be used when recording performance songs.

Numerator     1 or higher (denominator x 2-1)  
 Denominator   2, 4, 8, 16

1. Press the [Function] button.
2. Using the [-] and [+] Composer Select buttons, select "Beat."

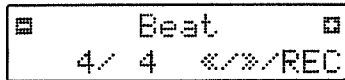

3. Use the [Bwd]/[Fwd] buttons to set the numeric value for the numerator.
4. To set the denominator, use the [Rec] button to move the cursor from the numerator to the denominator.  
 Press the [Rec] button again if you wish to return to the numerator.
5. Use the [Bwd]/[Fwd] buttons to set the numeric value for the denominator.

To return to the basic screen, press the [Function] button or the [Display/Exit] button.

- \* When recording your performance with playing Rhythm performances or Automatic Accompaniment, the beat is set automatically.
- \* You cannot change the beat of previously recorded songs.

## How the Expression Pedal Functions (Exp. Source)

Specify how the Expression Pedal will function when your performance is being recorded and when ATELIER song files are being played back.

### Function During Recording

Specify whether Expression Pedal operations will be recorded or not while your performance is being recorded.

1. Press the [Function] button.
2. Press the [-] or [+] Composer Select button to select "Exp. Source."

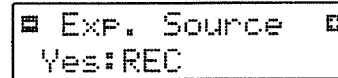

3. Press the [Rec] button.
4. Press the [-] or [+] Composer Select button to select "Recording."
5. Use the [Bwd]/[Fwd] buttons to specify the pedal function.

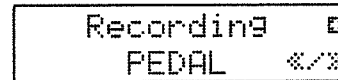

- |                 |                                                                                                               |
|-----------------|---------------------------------------------------------------------------------------------------------------|
| <b>PEDAL</b>    | Expression Pedal movements will be recorded. The previous recording will be erased as new songs are recorded. |
| <b>COMPOSER</b> | Expression Pedal movements will not be recorded. The previous data will remain without being erased.          |

To return to the basic screen, press the [Function] button.

## Settings for the Composer (Function Button)

### ■ Function During Playback

You can specify whether or not the Expression pedal will function while ATELIER song files are being played back.

1. Press the [Function] button.
2. Press the [-] or [+] Composer Select button to select "Exp. Source."

```
Exp. Source
Yes:REC
```

3. Press the [Rec] button.
4. Press the [-] or [+] Composer Select button to select "Playback."
5. Press the [Bwd]/[Fwd] buttons to specify the pedal function.

```
Playback
PEDAL+COMP </>
```

|            |                                                                                                            |
|------------|------------------------------------------------------------------------------------------------------------|
| PEDAL      | Expression pedal will function. The Expression Pedal recording within the song file will be ignored.       |
| COMPOSER   | Expression pedal will not function. The Expression pedal recording within the song file will be effective. |
| PEDAL+COMP | Expression pedal will function. Expression pedal recording within the song file will also be effective.    |

To return to the basic screen, press the [Function] button.

### Muting Individual Channels of Performance Data

You can mute (silence) individual channels of performance data of SMF data (sold separately).

\* It is not possible to mute the performance that you play on the AT-20R (except for the Rhythm and Automatic Accompaniment).

1. Press the [Function] button.
2. Use the Composer Select [-] [+] buttons to select "Ch.Mute."
3. Press the [Bwd] / [Fwd] buttons to select the channel that you wish to mute.

From the left, these are "1 Ch. (channel 1), 2 Ch. ... 15 Ch., and 16 Ch."

```
Ch.Mute</>/REC
1234567890123456
```

4. Press the [Rec] button.

```
Ch.Mute</>/REC
-234567890123456
```

The number will change to "-", indicating that the corresponding channel has been muted.

5. Once again press the [Rec] button, and muting will be canceled.

To return to the basic screen, press the [Function] button or the [Display/Exit] button.

\* Channel mute will be defeated when you perform the following operations.

- Use the Composer Select [-] and [+] buttons to select different performance data.
- Press the [All Song Play/Demo] button to play performance data.



## Switching the Display of Lyrics On (Displayed) or Off (Not Displayed)

---

Some music files have Lyrics included and these Lyrics can be displayed on the screen. You can turn on or off the lyrics display of such music files.

1. Press the [Function] button.
2. Use the [-] and [+] Composer Select buttons to select "Lyric."

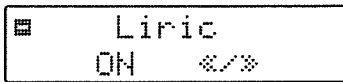

3. Press the [Bwd] / [Fwd] buttons to switch the lyric display "ON (displayed)" or "OFF (not displayed)."

To return to the basic screen, press the [Function] button.

\* If you press a voice select button etc. while playing back music files that contains lyrics, the display screen will switch, and the lyrics will no longer be displayed. To re-display the lyrics, press the [Play] button once again.

# Edit Menu (Editing Song Files)

Song files that you record can be edited using five different functions.

The following editing functions are provided.

|                |         |
|----------------|---------|
| Delete measure | (p. 82) |
| Delete Track   | (p. 83) |
| Erase          | (p. 84) |
| Copy           | (p. 85) |
| Quantize       | (p. 86) |

\* Once you edit data, it cannot be restored to its original condition. As a precaution against accidents, we recommend that you save your song to a floppy disk before you edit it.

## Delete Part of the Recorded Song (Delete Measure (Bar))

This function lets you delete specified measures (bars) of the song from all tracks. When any part of the song file is deleted, subsequent recording will be moved forward to fill the gap.

Example: To delete measures (bars) 5-8

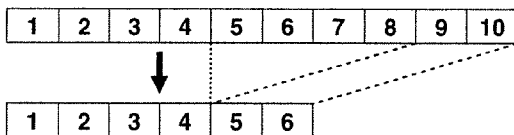

1. Press the [Function] button.
2. Use the [-] and [+] Composer Select buttons to select "Edit Menu."

```

Edit Menu
Yes:REC
  
```

3. Press the [Rec] button.
4. Use the [-] and [+] Composer Select buttons to select "Delete Measure."

```

Delete Measure
Yes:REC No:RST
  
```

To cancel the operation, press the [Reset] button.

5. Press the [Rec] button.
6. Use the [Bwd]/[Fwd] buttons to specify "from" (the delete start measure).

```

Delete Measure
from: 5 </>/REC
  
```

7. Press the [Rec] button.
8. Use the [Bwd]/[Fwd] buttons to specify "for" (number of measures from the delete start measure).

```

Delete Measure
for: 4 </>/REC
  
```

If you wish to delete from a certain measure (bar) to the last measure (bar), set for "ALL".

9. To execute the delete operation, press the [Rec] button once again.

The following screen will appear.

```

Delete Measure?
Yes:REC No:RST
  
```

To cancel the operation, press the [Reset] button.

10. Press the [Rec] button to start deleting the measure.

When the recording has been deleted, the basic screen will reappear.

## Delete the Recording from a Track (Delete Track)

This function lets you delete the recording from a track that you specify.

### What is a Track?

The AT-20R has seven tracks. These tracks record the following performance data.

|                |                                                                                                             |
|----------------|-------------------------------------------------------------------------------------------------------------|
| <b>Rhythm</b>  | Rhythm performance, Manual Drums                                                                            |
| <b>Accomp</b>  | Automatic Accompaniment (except Bass and Rhythm performance), SMF data (except Bass and Rhythm performance) |
| <b>Bass</b>    | Pedal Bass voice, Bass part of the Automatic Accompaniment, Bass part of the SMF data                       |
| <b>Lower</b>   | Lower voice                                                                                                 |
| <b>Upper</b>   | Upper voice                                                                                                 |
| <b>Solo</b>    | Solo voice                                                                                                  |
| <b>Control</b> | Panel operations (ex.: switching the buttons), Expression pedal operations, Part Balance Volume             |

\* SMF data (except for data that was saved by the ATELIER series) stores the Rhythm track in channel 10, and the remaining musical data in the Accomp and Bass tracks (p. 61).

1. Press the [Function] button.
2. Use the [-] and [+] Composer Select buttons to select "Edit Menu."
3. Press the [Rec] button.
4. Use the [-] and [+] Composer Select buttons to select "Delete Track."

```

Delete Track
Yes:REC No:RST
    
```

To cancel the operation, press the [Reset] button.

5. Press the [Rec] button.

6. Use the [Bwd]/[Fwd] buttons to select the track that you wish to delete.

```

Delete  */*/REC
Track : RHYTHM
    
```

Settings: RHYTHM, ACCOMP, BASS, LOWER, UPPER, SOLO, CONTROL

7. Press the [Rec] button.

The following display will appear.

```

Delete Track?
Yes:REC No:RST
    
```

To cancel the operation, press the [Reset] button.

8. Press the [Rec] button once again to execute the Delete Track function.

When the recording has been deleted, the basic screen will reappear.

## Erase Recording (Erase)

You can erase a specified portion of the performance in a specified area without making the song shorter. This is called the "Erase" function.

As an alternative to the method of erasing all performance data in a specified area, you can erase the following contents of the performance.

|            |                                       |
|------------|---------------------------------------|
| ALL        | All recording                         |
| NOTE       | Notes played on the keyboard          |
| CONTROL    | Panel operations, Part Balance Volume |
| EXPRESSION | Expression pedal recording            |
| VOICE      | Voice settings                        |
| TEMPO      | Tempo setting                         |

**Example:** Erasing measures (bars) 5–8

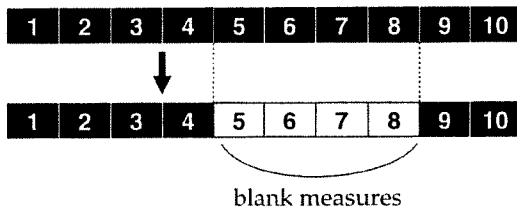

1. Press the [Function] button.
2. Use the [-] and [+] Composer Select buttons to select "Edit Menu."
3. Press the [Rec] button.
4. Use the [-] and [+] Composer Select buttons to select "Erase Event."

```

Erase Event
Yes:REC No:RST
    
```

To cancel the operation, press the [Reset] button.

5. Press the [Rec] button.
6. Use the [Bwd]/[Fwd] buttons to select the data to be erased.

```

Erase </>/REC
Event:ALL
    
```

Settings ALL, NOTE, CONTROL, EXPRESSION,  
VOICE, TEMPO

7. Press the [Rec] button.

8. Use the [Bwd] / [Fwd] buttons to select the track whose recording you wish to delete.

If you have selected EXPRESSION and TEMPO as the type of recording to be erased, the Track selection will not be available because the expression control recording is common to all tracks.

```

Erase </>/REC
Track: RHYTHM
    
```

Settings: ALL, RHYTHM, ACCOMP, BASS, LOWER,  
UPPER, SOLO

If you select "ALL", the recording will be erased from all tracks.

9. Press the [Rec] button.

10. Use the [Bwd] / [Fwd] buttons to specify "from" (erase start measure).

11. Press the [Rec] button.

12. Use the [Bwd] / [Fwd] buttons to specify "for" (number of measures from the erase start measure).

If you wish to erase to the last measure (bar), set "for: ALL."

13. Press the [Rec] button.

The following screen will appear.

```

Erase Event?
Yes:REC No:RST
    
```

To cancel the operation, press the [Reset] button.

14. Press the [Rec] button once again to execute the Erase function.

When erasure is complete, the basic screen will reappear.

## Copy Recording (Copy)

This function lets you copy a portion of recorded song to a different measure (bar) location in the same track.

\* If a recording already exists at the copy destination, it will be erased.

Example: If you wish to copy measures (bars) 5–7 to measure (bar) 8

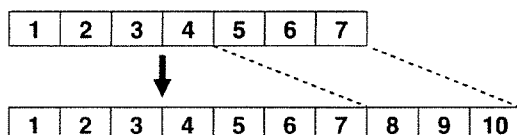

1. Press the [Function] button.
2. Use the [-] and [+] Composer Select buttons to select "Edit Menu."
3. Press the [Rec] button.
4. Use the [-] and [+] Composer Select buttons to select "Copy."

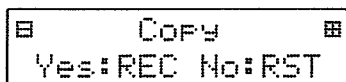

To cancel the operation, press the [Reset] button.

5. Press the [Rec] button.
6. Use the [Bwd]/[Fwd] buttons to select the track whose recording you wish to copy.



Settings: ALL, RHYTHM, ACCOMP, BASS, LOWER, UPPER, SOLO, CONTROL

If you select "ALL", the recording in all the tracks will be copied.

7. Press the [Rec] button.
8. Use the [Bwd] / [Fwd] buttons to specify "from" (copy start measure).

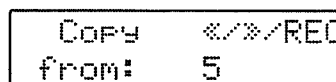

9. Press the [Rec] button.

10. Use the [Bwd] / [Fwd] buttons to specify "for" (number of measures from the copy start measure).

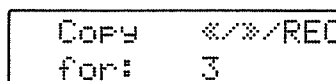

To specify until the last measure (bar), set "for: ALL".

11. Press the [Rec] button.

12. Use the [Bwd] / [Fwd] buttons to specify "to" (copy destination measure).

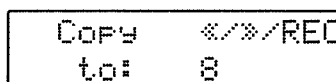

If you select "END," the data will be copied following the end of the last measure.

13. Press the [Rec] button.

14. Use the [Bwd] / [Fwd] buttons to specify "time" (number of times to copy the data).

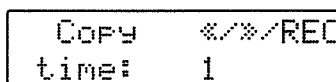

15. Press the [Rec] button.

The following screen will appear.

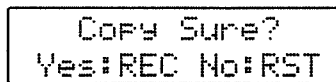

To cancel the operation, press the [Reset] button.

16. To execute the Copy function, press the [Rec] button once again.

When copying is complete, the basic screen will reappear.

### Correct Timing Inaccuracies (Quantize)

Quantize is a function that corrects the timing of notes to a specified resolution.

For example even if you intend to play at quarter-note timing, the notes may be slightly earlier or later than precise quarter-note intervals. In such cases, you can quantize to quarter note (1/4) timing to adjust the timing of the notes to precise quarter-note intervals.

1. Press the [Function] button.
2. Use the [-] and [+] Composer Select buttons to select "Edit Menu."
3. Press the [Rec] button.
4. Use the [-] and [+] Composer Select buttons to select "Quantize."

```
Quantize
Yes:REC No:RST
```

To cancel the operation, press the [Reset] button.

5. Press the [Rec] button.
6. Use the [Bwd]/[Fwd] buttons to select the track whose recording you wish to quantize.

```
Quantize </>/REC
Track : RHYTHM
```

Settings: ALL, RHYTHM, ACCOMP, BASS, LOWER,  
UPPER, SOLO

If you select "ALL", the recording in all the tracks will be quantized.

7. Press the [Rec] button.
8. Use the [Bwd] / [Fwd] buttons to specify "from" (quantize start measure).
9. Press the [Rec] button.
10. Use the [Bwd] / [Fwd] buttons to specify "for" (number of measures from the quantize start measure).

To specify the recording to the last measure (bar), set "for: ALL".



11. Press the [Rec] button.

12. Use the [Bwd] / [Fwd] button to specify "Res" (timing to which notes will be adjusted).



```
Quantize </>/REC
Res: ♩
```

"Res" (timing to which notes will be adjusted) can be set to the following values.

 Half note       Quarter note

 Quarter note triplet       8th note

 8th note triplet       16th note

 16th note triplet       32nd note

13. Press the [Rec] button.

The following display will appear.

```
Quantize Sure?
Yes:REC NO:RST
```

To cancel the operation, press the [Reset] button.

14. To execute the Quantize function, press the [Rec] button once again.

When quantization is completed, the basic screen will re-appear.

# Adjusting the Effects

You can customize the Reverb and Sustain effects by adjusting their values. The effects values are available for change in the following 3 menus:

|                        |
|------------------------|
| Reverb Type (p. 87)    |
| Reverb Depth (p. 88)   |
| Sustain (p. 88)        |
| Sustain Length (p. 88) |

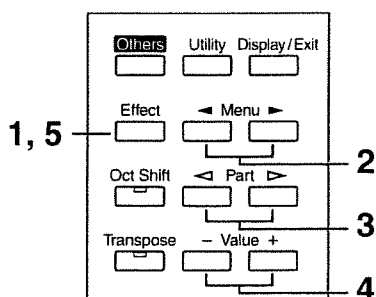

1. Press the [Effect] button.
2. Use the [◀] and [▶] Menu buttons to select the desired Menu.
3. When adjusting “Reverb Depth” or “Sustain Length”, use the [◀] and [▶] Part buttons to select the desired Part.
4. Use the [-] and [+] Value buttons to set the desired value.
5. To return to the basic screen, press the [Effect] or [Display/Exit] button.  
The basic screen will reappear.

## Changing the Reverb Type

You can select from the following eight types of Reverb:

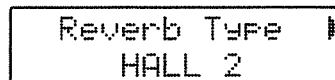

| Display   | Description                                                                              |
|-----------|------------------------------------------------------------------------------------------|
| ROOM 1    | Reverberation of a small room                                                            |
| ROOM 2    | Reverberation of a small club                                                            |
| ROOM 3    | Reverberation of a large room                                                            |
| HALL 1    | Reverberation of a large concert hall                                                    |
| HALL 2    | Reverberation of a small concert hall                                                    |
| PLATE     | A bright, metallic Reverberation                                                         |
| DELAY     | An echo-like sound repeated several times                                                |
| PAN DELAY | Similarly to the above but where the sound is panned between the left and right speakers |

\* It is not possible to modify the delay time (delay interval) when “PAN DELAY” is selected.

## Adjusting the Effects

---

### Changing the Reverb Depth

---

The depth of the Reverb can be set (0-10) for the following 16 Parts. You can make independent settings for each Part.

```
◀ Reverb Depth ▶  
◀ U.Organ : 8 ▶
```

Part **Accomp (Automatic Accompaniment except Bass), Rhythm, M.Drums, A.Bass (Bass part of Automatic Accompaniment), P.Bass, L.Organ, L.Orch, U.Organ,U.Orch, Solo**

Settings **0 – 10**

**AUTO (Accomp, Rhythm, A.Bass)**

For the three Parts of the Accomp, Rhythm and Accompaniment Bass, you have the option of selecting the “AUTO” setting. Parts for which “AUTO” is selected will be set to the Reverb Depth that is most suitable for the Rhythm currently selected.

### Sustain Effect

---

Sustain allows you to add a Sustain effect or decay to each voice after the keys are released.

```
◀ Sustain ▶  
◀ Upper : OFF ▶
```

Keyboard **Upper, Lower, Pedal**

**ON** The Sustain effect is applied to the voices

**OFF** The Sustain effect is not applied to the voices

### Changing the Sustain Length

---

The sustain length can be set independently (SHORT, MIDDLE (Medium) or LONG) for the Upper and Lower keyboards and Bass Pedalboard. You can make a separate setting for each keyboard.

```
◀ Sustain Length ▶  
Upper : LONG ▶
```

Keyboard **Upper, Lower, Pedal**

Settings **SHORT, MIDDLE, LONG**



# Various Other Settings (Utility Button)

You can adjust the settings for the following 19 items (menus).

---

## Initial Touch

Initial Touch ON/OFF

---

## Pedal Bass Mode

How the Pedal Bass voice can be played

---

## Solo Mode

Changing how the Solo voice will sound

---

## Registration Shift

Using the left Foot Switch to switch registrations

---

## Left Foot Switch Assignment

Selecting function for left Foot Switch

---

## Damper (Sustain) Pedal Assignment

Specifying which keyboard will be affected when you press the Damper (Sustain) pedal

---

## Glide Destination

Setting determines which keyboard will be affected when you use the Glide effect.

---

## Manual Drums Set

Selecting the Manual Drums type.

---

## Harmony Intelligence Type

Selecting the Harmony Intelligence type.

---

## Chord Intelligence

Chord Intelligence ON/OFF

---

## Chord Hold

Chord Hold ON/OFF

---

## Registration Arranger Update

Registration recall timing

---

## Registration Transpose Update

Transpose setting recall timing

---

## Tx MIDI Channel

MIDI output channel

---

## MIDI-IN Mode

---

## Send PC Switch

Specifying Transmission of PC Numbers

---

## PC Number

Specifying PC Numbers

---

## Master Tune

Adjusting the basic pitch

---

## LCD Contrast

Adjusting the contrast of the display

---

1. Press the [Utility] button.

2. Press the [◀] and [▶] Menu buttons to select the desired menu.

3. For “Initial Touch” or “Tx MIDI Channel,” use the [◀] and [▶] Part buttons to select the keyboard or part.

For “PC Number,” use the [◀] and [▶] Part buttons to select the settings.

4. Use the [-] and [+] Value buttons to set the desired value.

To return to the basic screen, press the [Utility] button or the [Display/Exit] button

---

## Initial Touch (Initial Touch ON/OFF)

---

Initial Touch is a function that translates the force used in playing the keys into a directly proportional amount of volume. It can be switched ON/OFF independently for the Upper and Lower Keyboards.

```
Initial Touch ▶
Upper : ON ▶
```

Part      **Upper, Lower**

**ON**      The harder you play the key, the higher the volume. Some voices switches the sound depending on the strength with which you play the keyboard.

**OFF**      Volume remains constant regardless of how hard you play.

## Various Other Settings (Utility Button)

---

### Pedal Bass Mode (How the Bass Pedalboard Can Be Played)

---

You can set the Bass Pedalboard to play simultaneous multiple notes or single notes only.



◀ PedalBass Mode ▶  
MONOPHONIC

**MONOPHONIC** Only single notes can be played.  
**POLYPHONIC** Multiple notes can be played.

### Solo Mode (Changing How the Solo Voice Will Sound)

---

When the Solo voice is assigned to the Upper keyboard, you can specify how the Solo voice will sound when more than one key is pressed.

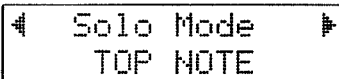

◀ Solo Mode ▶  
TOP NOTE

**TOP NOTE** The Solo voice will sound the highest note that is played for the Solo part.  
**LAST NOTE** The Solo voice will sound the note that was most recently played for the Solo part.  
**POLYPHONIC** The Solo voice will sound all notes that are played for the Solo part.

### Registration Shift (Use the Left Foot Switch to Switch Through Registrations)

---

You can use the left Foot Switch as a dedicated switch for selecting registrations in order.



◀ Regist Shift ▶  
OFF

**ON** Dedicated switch for selecting registrations  
**OFF** Functions other than selecting registrations can also be used

If Registration Shift is turned ON, each time you press the left Foot Switch, the registrations will be selected in the following order: 1 → 2 → 3 → ... → 12 → 1 → .. etc.

→ *This setting remains stored in memory even while the power is turned off.*

### Left Foot Switch Assignment

---

You can select any of the following functions and assign them to either Foot Switch on the left or left side of the Expression Pedal.

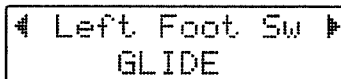

◀ Left Foot Sw ▶  
GLIDE

### Function

### Description

#### ROTARY FAST/SLOW

Switch the Rotary speed between "FAST" and "SLOW."

#### GLIDE

While the Foot Switch is pressed, the pitch will temporarily be lowered, and will gradually return to normal when you release the Foot Switch.

#### LEADING BASS

The Leading Bass function will operate only while you continue pressing the Foot Switch. When the Leading Bass function is enabled, the lowest note of the chord you play on the Lower keyboard will be used as the bass note (the bottom note of the chord).

#### RHYTHM START/STOP

Start/Stop the Rhythm.

#### COMPOSER PLAY/STOP

The same function as the Composer [Play] button and [Stop] button. Each time you press the Foot Switch, the performance data will play back or stop.

#### INTRO/ENDING

Play an Intro or Ending.

#### FILL IN TO VARIATION

After inserting a Fill-In, playback will switch to the variation pattern.

#### FILL IN TO ORIGINAL

After inserting a Fill-In, playback will switch to the original pattern.

#### ADVANCED/BASIC

Switch the pattern between the basic arrangement (BASIC) and a more complex arrangement (ADVANCED).

#### BREAK

Stop the Rhythm for one measure (break)

#### DAMPER OF UPPER

Notes played on the Upper keyboard will be sustained only while you continue pressing the Foot Switch.

\* If the Utility menu "Registration Shift" setting is "ON", the left Foot Switch will be dedicated to switching through the Registrations, and the "Left Foot Switch Assignment" setting will be ignored.

## Damper Pedal Assignment

You can specify which keyboard will be affected when you press the Damper (Sustain) pedal.

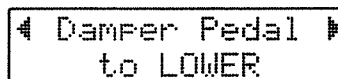

◀ Damper Pedal ▶  
to LOWER

**UPPER** The effect is applied to the voices played on the Upper keyboard.

**LOWER** The effect is applied to the voices played on the Lower keyboard.

If the voice is a percussive voice (such as a Piano voice), the tone will be sustained, but fade away just like an acoustic piano. If the voice is a non-percussive instrument (such as a String voice), the tone will be sustained as long as the pedal is depressed.

## Glide Destination

You can select the keyboard to which the effect will apply when you operate the Glide effect.

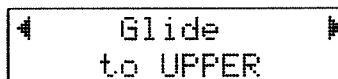

◀ Glide ▶  
to UPPER

**UPPER** The effect is applied to the voices played on the Upper keyboard.

**LOWER** The effect is applied to the voices played on the Lower keyboard.

**PEDAL** The effect is applied to the voices played on the Pedalboard.

## Various Other Settings (Utility Button)

---

### Manual Drums Set

---

This setting allows you to choose one of the following 8 Drum Sets or one Sound Effects Set.

ManualDrumsSet  
STANDARD

Settings     STANDARD, ROOM, POWER,  
                 ELECTRONIC, TR-808, JAZZ, BRUSH,  
                 ORCHESTRA, SOUND EFFECTS

→ The combination of sounds that are assigned to each key will differ depending on which Manual Drum Set is selected. For details refer to "Drum Set List" (p. 104).

→ You can select Manual Drum Set using the [Manual Drums] button and the [-] [+] Value buttons (p. 29).

### Harmony Intelligence Type (Selecting the Type of the Harmony Intelligence)

---

This setting allows you to select the type of the Harmony Intelligence.

Harmony Type  
TRADITIONAL

Settings     TRADITIONAL, HARP, OCTAVE1,  
                 OCTAVE2

### Chord Intelligence (Chord Intelligence ON/OFF)

---

"Chord Intelligence" is a feature that intelligently plays the correct accompaniment chords the moment you play a key specifying a chord on the Lower keyboard during Automatic Accompaniment.

To play a C chord on the Lower keyboard, for example, you usually have to press down the three keys C, E, and G; but with Chord Intelligence, you only have to press the C Key to initiate a C chord accompaniment.

Chord Intelli.  
ON

ON            Chord Intelligence function is ON  
OFF           Chord Intelligence function is OFF

\* For more information about chord fingering, see the "Chord List" (p. 107).

### Chord Hold (Chord Hold ON/OFF)

---

The Chord Hold function can be switched ON/OFF. When Chord Hold is ON, the Automatic Accompaniment will continue playing even when you lift your hand from the keyboard to play a new chord.

Chord Hold  
ON

ON            The Automatic Accompaniment determined by the chord played on the Lower keyboard is held (even if you release the keys).  
OFF           When you release the keys that you played in the Lower keyboard, the Automatic Accompaniment will stop (be muted). Only the Rhythm (drum) performance will continue.

## Registration Arranger Update (Arranger Settings Recall Timing)

You can specify how the settings related to Rhythm performances and Automatic Accompaniment will be recalled when you press a Registration button [1] – [4].

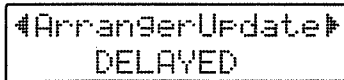

- DELAYED** Settings related to Rhythm performances and Automatic Accompaniment will be recalled when you hold a Registration button [1] – [4] for several seconds. If you quickly press the Registration button, only the panel settings (voice, etc.) that are not related to Rhythm and Automatic Accompaniment will be updated.
- INSTANT** Settings related to Rhythm performances and Automatic Accompaniment will be recalled the instant you press a button [1] – [4] along with all other panel settings.

→ This setting remains stored in memory even while power is turned off.

## Registration Transpose Update (Transpose Setting Recall Timing)

You can specify how the transpose setting will be recalled when you press a Registration button [1] – [4].

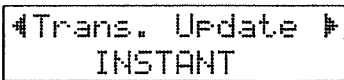

- DELAYED** Transpose settings will be recalled when you hold a Registration button [1] – [4] for several seconds.
- INSTANT** Transpose setting will be recalled the instant you press a button [1] – [4] along with all other panel settings.

→ This setting remains stored in memory even while power is turned off.

## Tx MIDI Channel (MIDI Output Channel)

When you use the MIDI connectors or the computer connector of the AT-20R to transmit musical data to external devices, for each keyboard (Upper, Lower, and Pedal) you can specify the channel on which your playing will be transmitted as MIDI messages. (Value: 1–16)

You can modify these Tx (Transmit) MIDI settings as needed. (For details refer to p. 97)

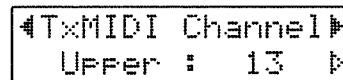

|         |                                     |
|---------|-------------------------------------|
| Part    | <b>Upper, Lower, Pedal, Control</b> |
| Channel | <b>1-16</b>                         |

- \* The CONTROL part transmits expression pedal data and PC numbers.
- \* It is not possible to set more than one part (Upper, Lower and Pedals) to the same channel.

→ The MIDI message of the Control track remains stored in memory even while power is turned off.

## Various Other Settings (Utility Button)

### MIDI IN Mode

This instrument contains two sound generators: one for SMF data playback and one for keyboard performance. Normally, data received at the MIDI In connector will control only the sound generator for SMF data playback. However by changing the MIDI IN Mode setting, you can also control the keyboard sound generator from MIDI In.

```

┌ MIDI IN Mode ──┐
│ MODE 1          │
└────────────────┘
    
```

- MODE 1** Control the instrument as a GS sound generator
- MODE 2** Channels 1–8 and channel 10 will be sent to the GS sound generator, and channel 9 and channels 11–16 will be sent to the keyboard sound generator.

| Ch  | MODE 1 | MODE 2        |
|-----|--------|---------------|
| 1–8 | GS     | GS            |
| 9   | GS     | Manual Drums  |
| 10  | GS     | GS            |
| 11  | GS     | Nothing       |
| 12  | GS     | Lower         |
| 13  | GS     | Upper         |
| 14  | GS     | Pedal Bass    |
| 15  | GS     | Nothing       |
| 16  | GS     | Solo, Control |

\* There are limitations on the types of MIDI messages that can be received by the keyboard sound generator. For details refer to the "Midi Implementation" (sold separately).

→ This setting remains stored in memory even while power is turned off.

### Send PC Switch (Specifying Transmission of PC Numbers)

Transmission of PC (Program Change) numbers can be switched ON/OFF.

```

┌ Send PC Switch ─┐
│ OFF              │
└────────────────┘
    
```

- ON** PC numbers are transmitted
- OFF** PC numbers are not transmitted

→ This setting remains stored in memory even while power is turned off.

### PC Number (Specifying PC Numbers)

You can specify the Program Change number that will be transmitted from MIDI Out when a Registration is selected.

```

┌ PC Number ───┐
│ PC Num: 1    │
└──────────┘
    
```

|         |                            |       |
|---------|----------------------------|-------|
| Setting | Bank MSB (Bank Select MSB) | 0-127 |
|         | Bank LSB (Bank Select LSB) | 0-127 |
|         | PC Num (PC Number)         | 1-128 |

Use the [ < ] and [ > ] Part buttons to select the settings.

## Master Tune

---

The basic pitch of an instrument is generally considered as the pitch of the middle A note. The "Master Tune" parameter lets you adjust this basic pitch to match the pitch of any other instruments that are playing together with the AT-20R.

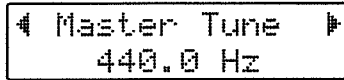

Settings      415.3Hz – 466.2Hz (0.1 Hz units)

- By pressing the [+] and [-] Value buttons simultaneously, you can restore the default setting (440.0 Hz).
- This setting remains stored in memory even while power is turned off.

## LCD Contrast

---

This setting allows you to adjust the contrast of the display.

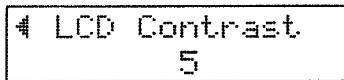

Available settings      1–10 (higher values will darken the display)

- This setting remains stored in memory even while power is turned off.

# Connecting External Devices

If you want to hook up an external instrument to the AT-20R, then this chapter is for you.

## Names and Functions of Jacks and Connectors

### 1 MIDI Out/In Connectors

You can connect external MIDI instruments to these connectors to exchange performance information.

### 2 Output L (mono)/R Jacks

You can some awesome sounds if you connect speakers or other audio equipment to these jacks. You can also hook up a portable stereo to record your performances on cassette tape.

### 3 Computer Connector

You can connect a computer to this connector to exchange performance information.

### 4 Computer Switch

Set this switch to Mac, PC-1, or PC-2 according to the type computer that's connected.

You can also switch between connections to the MIDI Out/In connectors and the Computer connector.

### 5 Pedal Connector

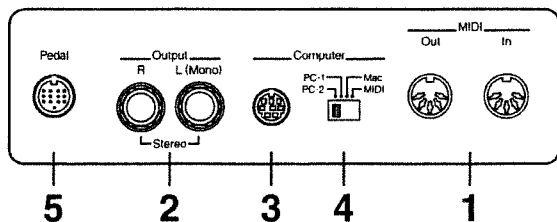

## Making the Connections

If you're planning on connecting the AT-20R to other equipment with cables, be sure to follow the steps shown below to make the connections. By turning on or off devices in the wrong order, you risk causing malfunction and/or damage to speakers and other devices.

1. Turn down the volume all the way on all equipment.
2. Turn off the power to the AT-20R and other connected equipment.
3. Connect the AT-20R and other equipment with the cables.
4. Turn on the connected equipment.
5. Turn on the AT-20R.
6. Adjust the volume.

● After use, follow the steps below to switch off the power.

1. Turn down the volume all the way on all equipment.
2. Turn off the AT-20R.
3. Turn off the connected equipment.

## ■ Connecting Audio Equipment

You can hook up a tape recorder or other audio device and record your performances on the AT-20R. Use an audio cable to connect the input jack on the audio set or amp mixer to one of the output jacks on the AT-20R. Use an audio cable with a standard plug. When purchasing an audio cable, please consult the vendor where you bought the AT-20R.

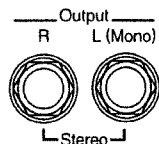



### ■ Connecting a Computer

The AT-20R provides a Computer connector. By connecting this to the serial port of your computer, you can transmit and receive musical data. Since the AT-20R is able to save musical data in SMF format, you can use your computer to edit the musical data.

1. Turn off the AT-20R and the computer.
2. Use a computer cable (sold separately) to connect the Computer connector on the AT-20R to a serial port on the computer.
3. Set the Computer switch on the bottom of the unit to match the type of connected computer.  
→ Take a look at the Connection Examples.
4. Turn on the computer.
5. Turn on the AT-20R.
6. Make the settings for baud rate (transmission speed) for the computer and the software.  
→ For more information, refer to the documentation for the computer you are using.
7. You should also make the settings for the MIDI send channel (p. 93).

#### Connection Examples:

##### ○ Connection with an Apple Macintosh computer

Use a computer cable (sold separately) to connect the Computer connector on the AT-20R to the modem port (or printer port) on the Apple Macintosh. Set the Computer switch to "Mac."

Use "PatchBay" on the Apple Macintosh to set the interface type (the clock speed for the MIDI interface) to "1 MHz."

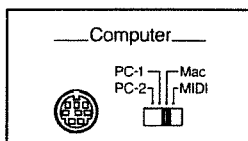

##### ○ Connection with an IBM PC

Use a computer cable (sold separately) to connect the Computer connector on the AT-20R to the COM1 or COM2 serial port on the IBM PC. Set the Computer switch to "PC-2."

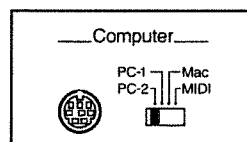

## If You're Using MIDI

### ● About MIDI

MIDI stands for "Musical Instrument Digital Interface," and is a unified standard for the exchange of performance data and other information between electronic instruments and computers.

The AT-20R is equipped with MIDI connectors and a Computer connector to let it exchange performance information with external devices. These connectors can be used to connect the AT-20R to an external device for even greater versatility.

### ● About MIDI Connectors

The AT-20R has two kinds of MIDI connectors.

Connecting these to the MIDI connectors on a MIDI instrument makes it possible for the two instruments to control each other.

For instance, you can output sound from the other instrument or switch tones on the other instrument.

You should also set the MIDI send channel as needed.

### ○ MIDI Out Connector

Only the notes played on the keyboard, movements of the Damper pedal, Expression data, and data indicating that a Registration button [1]–[4] was pressed will be transmitted to the external MIDI connector.

## Connecting External Devices

### ○ MIDI In Connector

Performance messages from an external MIDI device are received here.

These incoming messages may instruct the receiving MIDI instrument to play sounds or switch tones.

The AT-20R contains two sound generators: one sound generator for its own keyboards and one GS sound generator (p. 111). Normally, musical data transmitted from an external device to the MIDI In connector is sent to the GS sound generator, but you can also set the "MIDI IN Mode" parameter (p. 94) so that the keyboard sound generator is controlled.

### ■ Connecting the AT-20R to a MIDI Instrument

1. Turn off the AT-20R.
2. Set the Computer switch on the bottom of the AT-20R to "MIDI."

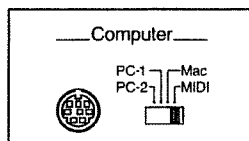

\* When the AT-20R is powered up, the setting doesn't change until the power is reset, even if the computer switch is operated.

3. Use a MIDI cable (sold separately) to connect the MIDI connector on the external instrument to the MIDI connector on the AT-20R.
4. Turn on the external MIDI device and AT-20R.
5. You should also set the MIDI send channel and switch Local Control on or off as needed.

### Connection Example:

#### ○ Connecting the MIDI Device

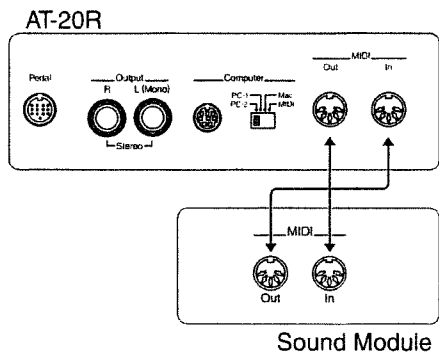

\* A separate publication titled "MIDI Implementation" is also available. It provides complete details concerning the way MIDI has been implemented on this unit. If you should require this publication (such as when you intend to carry out byte-level programming), please contact the nearest Roland Service Center or authorized Roland distributor.

# Troubleshooting

## **When you press the [Power] switch, the power doesn't come on.**

- Power cord is not connected correctly (p. 14).

## **No sound is heard.**

- The [Master Volume] slider is set too low (p. 15).
- Headphones are connected (p. 15).  
When you connect the headphones, the sound is heard only through the headphones.
- The volume of each Part Balance button is set too low (p. 26).
- The volume is set too low on the Expression Pedal (p. 46).
- You do not have a voice selected (p. 19).  
Voices that have their button indicator lit can be played.
- You have selected Manual Drums for the Lower keyboard, and are playing a key to which no drum sound or Sound Effect has been assigned (p. 28, p. 104).

## **No sound is heard (when a MIDI instrument is connected).**

- The power of the connected external devices is not turned on (p. 96).
- The Computer switch on the bottom of the unit is not set to "MIDI" (p. 97).

## **Damper Pedal does not operate**

- The damper pedal affects only the Lower keyboard. The damper pedal does not affect the Bass Pedalboard.  
You can change the settings so that the damper pedal affects the Upper keyboard (p. 91).
- The damper pedal does not affect the Solo voice.

## **Expression Pedal does not operate**

- The Expression Pedal will not function while playing back performance data (SMF music data) from a device other than the Atelier series.
- The function of the Expression Pedal during recording (p. 79) or the function during playback (p. 80) has been set to "COMPOSER."

## **Can't use the function assigned to the right foot switch**

- If the Utility menu item "Registration Shift" (change Registrations) is ON (p. 90), the right foot switch will be dedicated to switching the Registration.

## **When the Human Voice "Jazz Scat" is selected, playing dynamics do not change the sound**

- The Utility menu item "Initial Touch" is turned OFF (p. 89).

## **Rotary effect is not be applied.**

- Some sounds do not allow the rotary effect to be applied (p. 103).

## **When you release your fingers from keys in the Lower keyboard while Automatic Accompaniment and Rhythm are playing, the Rhythm performance only remains playing.**

- Chord Hold is at OFF (p. 92).  
The Automatic Accompaniment will play while you press a chord. If Chord Hold is turned ON, the Automatic Accompaniment will continue playing with the Rhythm even when you take your hand off of the Lower keyboard.

## **Even though you press only one key, a multiple number of notes sound.**

- Harmony Intelligence is at ON (p. 40).
- Chord Intelligence is turned ON (p. 92).

## **Automatic Accompaniment sounds odd**

- The keys for a chord were not pressed simultaneously.
- When Chord Intelligence is OFF (p. 92), the chord is not being pressed correctly.
- When performance data from a device other than the AT-20R is being played together with the Automatic Accompaniment, the Automatic Accompaniment may not be sounded correctly.

## **Rhythm sounds odd**

- When performance data from a device other than the AT-20R is being played together with the Automatic Accompaniment, the Rhythm performance may not be sounded correctly.

## **Pitch is off.**

- Transpose is in effect (p. 45).
- The tuning is incorrect (p. 95).
- While set for an octave shift (p. 27), you are playing keys beyond the recommended range. This does not indicate a malfunction.

## **Performance data cannot be played back**

- While the Function menu appears in the display (with the exception of Channel Mute), playback is not allowed. If you wish to playback performance data, press the [Function] button once again to exit the Function menu (p. 78).

## Troubleshooting

---

### Recording is not possible

- Punch-in recording has been selected (p. 74).
- If you wish to erase a previously-recorded track and then re-record, press the track button for the desired track to make that button indicator blink before you begin recording (p. 62).
- While the Function menu appears in the display (with the exception of Channel Mute), recording is not allowed. If you wish to record performance data, press the [Function] button once again to exit the Function menu.

### Lyrics are not indicated properly in the display

- With some music files, the lyrics cannot be displayed correctly.
- If you press a button while the lyrics are being shown in the display, the lyrics will disappear. To recall them, press the [Play] button.

### The recorded performance has disappeared

- Any performance that has been recorded is deleted when the power to the unit is turned off. A performance cannot be restored once it's been deleted, so be sure to save it on a floppy disk before you turn off the power (p. 67).

### The bass note of the Automatic Accompaniment does not sound

- When a voice is selected for the Pedal Bass part, the bass of the Automatic Accompaniment will not sound.

### When you started a Rhythm with an Intro, the Rhythm did not sound

- Some Rhythms do not have rhythm sounds in the intro.

### MIDI messages received at MIDI In are not sounded

- The Computer switch is not set to "MIDI" position (p. 97).
- The Computer switch was set to "MIDI" after the power was turned on.  
Turn off the power, and then turn the power on once again.

### Sound is distorted / cracked

- The Part Balance volume of each part is too high (p. 26).
- The Reverb volume has been raised when the volume of each Part Balance button is already raised.  
Either lower the Reverb volume, or adjust the Part Balance of each part (p. 26).
- The [Master Volume] knob has been used to raise the overall volume excessively (p. 15).

### Some keys (of certain keyboard parts) sound strange

- You've assigned the same voice, using the same range, to multiple parts.

### The Rhythm does not change when you press the Registration [1]-[4] buttons

- The settings at which Registrations are recalled (Registration Arranger Update) has been set to "DELAYED" (p. 93).

### The volume changes during playback of performance data

- When recording is performed repeatedly while changing the Part Balance volume, the previously-recorded Part Balance data remains in the Control track. If you wish to get rid of the volume changes, use the Erase function (p. 84) to delete the Part Balance data.

### Bass is heard even though you are not playing the Bass Pedalboard

- The [To Lower] button (p. 44) is ON.  
When the [To Lower] button is ON, the Bass will be sounded by the Lower keyboard.

### When playing the same sound in the Upper keyboard and Lower keyboard, the volume is different

- On one of the keyboards, "Initial Touch" is turned ON (p. 89).

### Lower keyboard cannot be heard

- The Lower keyboard will not produce sound while an Intro or Ending is being played.

### The sound is not played correctly

- If you layer the same type of sound, or play an octave-shifted organ sound, the timing at which you play a note or the phase relationship between the two sounds may affect the way in which the sounds are heard, but this is not a malfunction.

### Can't play the demo songs

- A floppy disk is inserted in the disk drive.  
In order to play the demo song, you must remove the floppy disk from the disk drive (p. 37).

### Can't select Rhythms from a Music Style disk

- The Rhythm [Disk] button has not been selected (p. 37).

# Display Messages

## ■ E.00

Copy Protected.  
Can't Save

Meanings:

- To protect the copyright, this music file cannot be saved as SMF format.
- When you want to save as Atelier format, you can save only original disk.

## ■ E.01

Can't Save  
This Song.

Meanings:

- You can only play the music data. It cannot be saved on a floppy disk or internal memory.

## ■ E.02

Write Protected  
Disk

Meanings:

- The protect tab on the floppy disk is set to the Protect position.  
Change it to the Write position and repeat the procedure.

## ■ E.03

Master Disk

Meanings:

- This floppy disk cannot store the format or save any data.  
Insert a different disk and repeat the procedure.

## ■ E.05

Read Only Song.  
Can't Save

Meanings:

- A new song cannot be saved onto this floppy disk.

## ■ E.10

No Disk

Meanings:

- No floppy disk is connected to the disk drive. Insert the disk correctly, and repeat the procedure.

## ■ E.11

Disk Full

Meanings:

- There is not sufficient space left on the floppy disk for the data to be saved. Save the data onto a different floppy disk or delete music data on the disk.

## ■ E.12

Unknown Disk

Meanings:

- The floppy disk inserted into the disk drive cannot be read.  
Please format the floppy disk.

## ■ E.13

Disk Ejected

Meanings:

- The floppy disk was removed from the disk drive while loading or writing was in progress. Insert the floppy disk and repeat the procedure.

## ■ E.14

Damaged Disk

Meanings:

- This floppy disk is damaged and cannot be used. Insert a different disk and repeat the procedure.

## ■ E.15

Can't Read

Meanings:

- This song cannot be read.

## ■ E.16

Can't Play

Meanings:

- It cannot be read the floppy disk quickly enough. Press the [Reset] button, then press the [Play] button to play the song.

## Display Messages

---

### ■ E.30

Memory Full

#### Meanings:

- The Rhythm data is excessively large, and cannot be loaded.
- The performance data is excessively large, and cannot be loaded.
- Since the internal memory is full, recording or editing is not possible.

### ■ E.40

MIDI Buffer Full

#### Meanings:

- The AT-20R cannot deal with the excessive MIDI data sent from the external MIDI device. Reduce the amount of MIDI data sent to the AT-20R.

### ■ E.41

Communication  
Error

#### Meanings:

- A MIDI cable or computer cable has been disconnected. Connect it properly and securely.

### ■ E.43

Computer I/F  
Error

#### Meanings:

- The Computer Switch is set to a wrong position or the computer is set wrongly. Switch off the AT-20R then set the Computer Switch to the correct position and set the computer correctly. After that, switch on the AT-20R again.

### ■ E.51

Memory Error

#### Meanings:

- There is something wrong with the system. Repeat the procedure from the beginning.

### ■ Others

Factory Preset  
is Loaded.

#### Meanings:

- The internal settings (Registrations, etc.) were lost, because the instrument was not turned on for about two weeks. The basic screen will appear after the instrument has been returned automatically to all the factory default settings.

Internal Memory  
Near Limit

#### Meanings:

- The AT-20R is warning you that its memory will soon become full to capacity, so not much more recording can be done.

Clear Song Sure?  
Yes:REC No:RST

#### Meanings:

- To carry out the procedure, you first need to erase performance data in the AT-20R. This message asks you to confirm that you don't mind doing this. To erase the data, press the [Rec] button. When you do not want to erase it, press the [Reset] button then save the data on disk.

OverwriteRegist?  
Yes:REC No:RST

#### Meanings:

- This Registration is already being used. To overwrite the previous Registration data in this memory, press the [Rec] button. If you decide to keep the previous Registration data in this memory and save your settings in an unused memory, press the [Reset] button, press the [Select] button to select a number for which "—" is displayed, and then save the data.

Overwrite Song ?  
Yes:REC No:RST

#### Meanings:

- There already is performance data having the same name on the disk. To replace the existing data with the new version, press the [Rec] button. To save it as a separate new file, press the [Reset] button first. Then, after changing the name, save it on disk.

# Voice List

|     |              |    |     |              |     |              |
|-----|--------------|----|-----|--------------|-----|--------------|
| A11 | Full Organ1  | *1 | I11 | Violin       | Q51 | Soprano Sax  |
| A12 | Full Organ2  | *1 | I12 | Viola        | Q61 | Alto Sax     |
| A13 | Full Organ3  | *1 | I13 | Cello        | Q71 | Tenor Sax    |
| A14 | Full Organ4  | *1 | I14 | Pizzicato    | R11 | Flute        |
| A15 | Full Organ5  | *1 | J11 | Jazz Scat    | R22 | Pan Flute    |
| A16 | Full Organ6  | *1 | J12 | Pop Voice    | R31 | Oboe         |
| B11 | Jazz Organ1  | *1 | J13 | Jazz Doo     | R32 | Bassoon      |
| B12 | Jazz Organ2  | *1 | J14 | Jazz Doot    | R41 | Clarinet     |
| B13 | Jazz Organ3  | *1 | J15 | Jazz Dat     | R51 | Shakuhachi   |
| B14 | Jazz Organ4  | *1 | J16 | Jazz Bap     | S11 | Synth. Lead1 |
| B15 | Jazz Organ5  | *1 | J17 | JazzDowfall  | S12 | Synth. Lead2 |
| B16 | Jazz Organ6  | *1 | J21 | Choir        | T11 | Organ Bass1  |
| B21 | Rock Organ1  |    | K11 | Grand Piano  | T12 | Organ Bass2  |
| B22 | Rock Organ2  |    | K21 | Honky-tonk   | T21 | Pipe Org. Bs |
| C11 | Lower Organ1 | *1 | K31 | E.Piano1     | T31 | String Bass  |
| C12 | Lower Organ2 | *1 | K32 | E.Piano2     | T32 | Bass+Cymbal  |
| C13 | Lower Organ3 | *1 | K41 | Harpsichord  | T41 | Contrabass1  |
| C14 | Lower Organ4 | *1 | K42 | Clavi.       | T51 | E.Bass1      |
| C15 | Lower Organ5 | *1 | L11 | Accordion    | T52 | E.Bass2      |
| C16 | Lower Organ6 | *1 | L21 | Harmonica    | T61 | Tuba         |
| D11 | Pipe Organ1  |    | M11 | Nylon-str.Gt | T71 | Synth. Bass1 |
| D12 | Pipe Organ2  |    | M21 | Steel-str.Gt | T81 | Voice Thum   |
| D13 | Pipe Organ3  |    | M31 | Jazz Guitar  |     |              |
| D14 | Pipe Organ4  |    | M41 | Overdrive Gt |     |              |
| D15 | Pipe Organ5  |    | N11 | Hawaiian Gt. |     |              |
| D16 | Pipe Organ6  |    | N12 | Banjo        |     |              |
| D17 | Pipe Organ7  |    | N21 | Harp         |     |              |
| D21 | Diapason 8'  |    | N31 | Sitar        |     |              |
| E11 | Theater Or.1 |    | O11 | Vibraphone   |     |              |
| E12 | Theater Or.2 |    | O12 | Glockenspiel |     |              |
| E13 | Theater Or.3 |    | O13 | Celesta      |     |              |
| E14 | Theater Or.4 |    | O21 | Marimba      |     |              |
| E15 | Theater Or.5 |    | O22 | Xylophone    |     |              |
| E16 | Theater Or.6 |    | O31 | Tubular-bell |     |              |
| F11 | Synth. Org.1 |    | O41 | Steel Drums  |     |              |
| F12 | Synth. Org.2 |    | P11 | Tp. Section  |     |              |
| G11 | Strings1     |    | P21 | Fr.Horn Sect |     |              |
| G12 | Strings2     |    | P31 | Sax.Section  |     |              |
| H11 | Slow Str.1   |    | P41 | Synth. Brass |     |              |
| H21 | Synth. Str.1 |    | Q11 | Trumpet      |     |              |
| H22 | Synth. Str.2 |    | Q21 | Mute Trumpet |     |              |
| H31 | Synth. Pad1  |    | Q31 | Trombone     |     |              |
| H32 | Synth. Pad2  |    | Q41 | Flugel Horn  |     |              |

\*1: Rotary: effective

# Drum Set List

## Manual Drum Set

|    | JAZZ<br>STANDARD           | ROOM                    | POWER                   | ELECTRONIC              |
|----|----------------------------|-------------------------|-------------------------|-------------------------|
| C2 | 36 Std Kick 1              | Std Kick 1              | MONDO Kick              | Elec BD                 |
|    | 37 Side Stick              | Side Stick              | Side Stick              | Side Stick              |
|    | 38 Snare Drum 1            | Snare Drum 1            | Gated SD                | Elec SD                 |
|    | 39 Hand Clap               | Hand Clap               | Hand Clap               | Hand Clap               |
|    | 40 Snare Drum 2            | Snare Drum 2            | Snare Drum 2            | Gated SD                |
|    | 41 Low Tom 2               | Room Low Tom 2          | Room Low Tom 2          | Elec Low Tom 2          |
|    | 42 Closed Hi-hat 1 [EXC1]  | Closed Hi-hat 1 [EXC1]  | Closed Hi-hat 1 [EXC1]  | Closed Hi-hat 1 [EXC1]  |
|    | 43 Low Tom 1               | Room Low Tom 1          | Room Low Tom 1          | Elec Low Tom 1          |
|    | 44 Pedal Hi-hat 1 [EXC1]   | Pedal Hi-hat 1 [EXC1]   | Pedal Hi-hat 1 [EXC1]   | Pedal Hi-hat 1 [EXC1]   |
|    | 45 Mid Tom 2               | Room Mid Tom 2          | Room Mid Tom 2          | Elec Mid Tom 2          |
|    | 46 Open Hi-hat 1 [EXC1]    | Open Hi-hat 1 [EXC1]    | Open Hi-hat 1 [EXC1]    | Open Hi-hat 1 [EXC1]    |
|    | 47 Mid Tom 1               | Room Mid Tom 1          | Room Mid Tom 1          | Elec Mid Tom 1          |
| C3 | 48 High Tom 2              | Room Hi Tom 2           | Room Hi Tom 2           | Elec Hi Tom 2           |
|    | 49 Crash Cymbal 1          | Crash Cymbal 1          | Crash Cymbal 1          | Crash Cymbal 1          |
|    | 50 High Tom 1              | Room Hi Tom 1           | Room Hi Tom 1           | Elec Hi Tom 1           |
|    | 51 Ride Cymbal 1           | Ride Cymbal 1           | Ride Cymbal 1           | Ride Cymbal 1           |
|    | 52 Chinese Cymbal          | Chinese Cymbal          | Chinese Cymbal          | Reverse Cymbal          |
|    | 53 Ride Bell               | Ride Bell               | Ride Bell               | Ride Bell               |
|    | 54 Tambourine              | Tambourine              | Tambourine              | Tambourine              |
|    | 55 Splash Cymbal           | Splash Cymbal           | Splash Cymbal           | Splash Cymbal           |
|    | 56 Cowbell                 | Cowbell                 | Cowbell                 | Cowbell                 |
|    | 57 Crash Cymbal 2          | Crash Cymbal 2          | Crash Cymbal 2          | Crash Cymbal 2          |
|    | 58 Vibra-slap              | Vibra-slap              | Vibra-slap              | Vibra-slap              |
|    | 59 Ride Cymbal 2           | Ride Cymbal 2           | Ride Cymbal 2           | Ride Cymbal 2           |
| C4 | 60 High Bongo              | High Bongo              | High Bongo              | High Bongo              |
|    | 61 Low Bongo               | Low Bongo               | Low Bongo               | Low Bongo               |
|    | 62 Mute High Conga         | Mute High Conga         | Mute High Conga         | Mute High Conga         |
|    | 63 Open High Conga         | Open High Conga         | Open High Conga         | Open High Conga         |
|    | 64 Low Conga               | Low Conga               | Low Conga               | Low Conga               |
|    | 65 High Timbale            | High Timbale            | High Timbale            | High Timbale            |
|    | 66 Low Timbale             | Low Timbale             | Low Timbale             | Low Timbale             |
|    | 67 High Agogo              | High Agogo              | High Agogo              | High Agogo              |
|    | 68 Low Agogo               | Low Agogo               | Low Agogo               | Low Agogo               |
|    | 69 Cabasa                  | Cabasa                  | Cabasa                  | Cabasa                  |
|    | 70 Maracas                 | Maracas                 | Maracas                 | Maracas                 |
|    | 71 Short Hi Whistle [EXC2] | Short Hi Whistle [EXC2] | Short Hi Whistle [EXC2] | Short Hi Whistle [EXC2] |
| C5 | 72 Long Low Whistle [EXC2] | Long Low Whistle [EXC2] | Long Low Whistle [EXC2] | Long Low Whistle [EXC2] |
|    | 73 Short Guiro [EXC3]      | Short Guiro [EXC3]      | Short Guiro [EXC3]      | Short Guiro [EXC3]      |
|    | 74 Long Guiro [EXC3]       | Long Guiro [EXC3]       | Long Guiro [EXC3]       | Long Guiro [EXC3]       |
|    | 75 Claves                  | Claves                  | Claves                  | Claves                  |
|    | 76 High Wood Block         | High Wood Block         | High Wood Block         | High Wood Block         |
|    | 77 Low Wood Block          | Low Wood Block          | Low Wood Block          | Low Wood Block          |
|    | 78 Mute Cuica [EXC4]       | Mute Cuica [EXC4]       | Mute Cuica [EXC4]       | Mute Cuica [EXC4]       |
|    | 79 Open Cuica [EXC4]       | Open Cuica [EXC4]       | Open Cuica [EXC4]       | Open Cuica [EXC4]       |
|    | 80 Mute Triangle [EXC5]    | Mute Triangle [EXC5]    | Mute Triangle [EXC5]    | Mute Triangle [EXC5]    |
|    | 81 Open Triangle [EXC5]    | Open Triangle [EXC5]    | Open Triangle [EXC5]    | Open Triangle [EXC5]    |
|    | 82 Shaker                  | Shaker                  | Shaker                  | Shaker                  |
|    | 83 Jingle Bell             | Jingle Bell             | Jingle Bell             | Jingle Bell             |
| C6 | 84 Bell Tree               | Bell Tree               | Bell Tree               | Bell Tree               |
|    | 85 Castanets               | Castanets               | Castanets               | Castanets               |
|    | 86 Mute Surdo [EXC6]       | Mute Surdo [EXC6]       | Mute Surdo [EXC6]       | Mute Surdo [EXC6]       |
|    | 87 Open Surdo [EXC6]       | Open Surdo [EXC6]       | Open Surdo [EXC6]       | Open Surdo [EXC6]       |
|    | 88 -----                   | -----                   | -----                   | -----                   |

--- : no sound

[EXC] : will not sound simultaneously with other percussion instruments of the same number



# Drum Set List

|       | TR-808                  | BRUSH                   | ORCHESTRA               | SOUND EFFECT                |
|-------|-------------------------|-------------------------|-------------------------|-----------------------------|
| C2 36 | 808 Bass Drum 1         | Std Kick 1              | Concert BD 1            | -----                       |
| 37    | 808 Rim Shot            | Side Stick              | Side Stick              | -----                       |
| 38    | 808 Snare Drum          | Brush Tap               | Concert SD              | -----                       |
| 39    | Hand Clap               | Brush Slap              | Castanets               | High Q                      |
| 40    | Snare Drum 2            | Brush Swirl             | Concert SD              | Slap                        |
| 41    | 808 Low Tom 2           | Low Tom 2               | Timpani F               | Scratch Push [EXC7]         |
| 42    | 808 CHH [EXC1]          | Closed Hi-hat 1 [EXC1]  | Timpani F#              | Scratch Pull [EXC7]         |
| 43    | 808 Low Tom 1           | Low Tom 1               | Timpani G               | Sticks                      |
| 44    | 808 CHH [EXC1]          | Pedal Hi-hat 1 [EXC1]   | Timpani G#              | Square Click                |
| 45    | 808 Mid Tom 2           | Mid Tom 2               | Timpani A               | Metronome Click             |
| 46    | 808 OHH [EXC1]          | Open Hi-hat 1 [EXC1]    | Timpani A#              | Metronome Bell              |
| 47    | 808 Mid Tom 1           | Mid Tom 1               | Timpani B               | Guitar sliding Finger       |
| C3 48 | 808 Hi Tom 2            | High Tom 2              | Timpani c               | Guitar cutting noise (down) |
| 49    | 808 Cymbal              | Crash Cymbal 1          | Timpani c#              | Guitar cutting noise (up)   |
| 50    | 808 Hi Tom 1            | High Tom 1              | Timpani d               | String slap of double bass  |
| 51    | Ride Cymbal 1           | Ride Cymbal 1           | Timpani d#              | FLKey Click                 |
| 52    | Chinese Cymbal          | Chinese Cymbal          | Timpani e               | Laughing                    |
|       | Ride Bell               | Ride Bell               | Timpani f               | Screaming                   |
| 53    | Tambourine              | Tambourine              | Tambourine              | Punch                       |
| 54    | Splash Cymbal           | Splash Cymbal           | Splash Cymbal           | Heart Beat                  |
| 55    | 808 Cowbell             | Cowbell                 | Cowbell                 | Footsteps1                  |
| 56    | Crash Cymbal 2          | Crash Cymbal 2          | Concert Cymbal 2        | Footsteps2                  |
| 57    | Vibra-slap              | Vibra-slap              | Vibra-slap              | Applause                    |
| 58    | Ride Cymbal 2           | Ride Cymbal 2           | Concert Cymbal 1        | Door Creaking               |
| C4 60 | High Bongo              | High Bongo              | High Bongo              | Door                        |
| 61    | Low Bongo               | Low Bongo               | Low Bongo               | Scratch                     |
| 62    | 808 High Conga          | Mute High Conga         | Mute High Conga         | Wind Chimes                 |
| 63    | 808 Mid Conga           | Open High Conga         | Open High Conga         | Car-Engine                  |
| 64    | 808 Low Conga           | Low Conga               | Low Conga               | Car-Stop                    |
|       | High Timbale            | High Timbale            | High Timbale            | Car-Pass                    |
| 65    | Low Timbale             | Low Timbale             | Low Timbale             | Car-Crash                   |
| 66    | High Agogo              | High Agogo              | High Agogo              | Siren                       |
| 67    | Low Agogo               | Low Agogo               | Low Agogo               | Train                       |
| 68    | Cabasa                  | Cabasa                  | Cabasa                  | Jetplane                    |
| 69    | 808 Maracas             | Maracas                 | Maracas                 | Helicopter                  |
| 70    | Short Hi Whistle [EXC2] | Short Hi Whistle [EXC2] | Short Hi Whistle [EXC2] | Starship                    |
| C5 72 | Long Low Whistle [EXC2] | Long Low Whistle [EXC2] | Long Low Whistle [EXC2] | Gun Shot                    |
| 73    | Short Guiro [EXC3]      | Short Guiro [EXC3]      | Short Guiro [EXC3]      | Machine Gun                 |
| 74    | Long Guiro [EXC3]       | Long Guiro [EXC3]       | Long Guiro [EXC3]       | Lasergun                    |
| 75    | 808 Claves              | Claves                  | Claves                  | Explosion                   |
| 76    | High Wood Block         | High Wood Block         | High Wood Block         | Dog                         |
|       | Low Wood Block          | Low Wood Block          | Low Wood Block          | Horse-Gallop                |
| 77    | Mute Cuica [EXC4]       | Mute Cuica [EXC4]       | Mute Cuica [EXC4]       | Birds                       |
| 78    | Open Cuica [EXC4]       | Open Cuica [EXC4]       | Open Cuica [EXC4]       | Rain                        |
| 79    | Mute Triangle [EXC5]    | Mute Triangle [EXC5]    | Mute Triangle [EXC5]    | Thunder                     |
| 80    | Open Triangle [EXC5]    | Open Triangle [EXC5]    | Open Triangle [EXC5]    | Wind                        |
| 81    | Shaker                  | Shaker                  | Shaker                  | Seashore                    |
| 82    | Jingle Bell             | Jingle Bell             | Jingle Bell             | Stream                      |
| C6 84 | Bell Tree               | Bell Tree               | Bell Tree               | Bubble                      |
| 85    | Castanets               | Castanets               | Castanets               | Cat                         |
| 86    | Mute Surdo [EXC6]       | Mute Surdo [EXC6]       | Mute Surdo [EXC6]       | -----                       |
| 87    | Open Surdo [EXC6]       | Open Surdo [EXC6]       | Open Surdo [EXC6]       | -----                       |
| 88    | -----                   | -----                   | Applause                | -----                       |

--- : no sound

[EXC] : will not sound simultaneously with other percussion instruments of the same number

# Style List

## **[Big Band/Swing]**

---

BigBandSwing  
Big Band  
A Cappella  
Combo

## **[Country]**

---

Hoedown  
CountryWaltz  
Easy Country

## **[Oldies]**

---

Twist  
50's Pop 1  
Slow Dance

## **[Ballad]**

---

Love Songs  
Torch Song  
Love Romance

## **[Acoustic]**

---

G.Pop  
P.Slow  
P.Night

## **[Latin1]**

---

Slow Bossa  
Bossa Nova  
Salsa

## **[Latin2]**

---

Rhumba  
Mambo  
Tango 1  
Samba Rio

## **[Pop]**

---

Swing Pop  
Easy Listen1  
Easy Listen2  
Raindrops

## **[Waltz/March]**

---

Slow Waltz  
March 4/4  
March 6/8

## **[Disk]**

---

Hawaiian  
Dixieland

# Chord List

● symbol : Indicates the constituent note of chords.

★ symbol : Chord shown with an "★" can be played by pressing just the key marked with the "★".

|          |           |          |                   |          |          |
|----------|-----------|----------|-------------------|----------|----------|
| C        | C#        | D        | E $\flat$         | E        | F        |
| CM7      | C#M7      | DM7      | E $\flat$ M7      | EM7      | FM7      |
| C7       | C#7       | D7       | E $\flat$ 7       | E7       | F7       |
| Cm       | C#m       | Dm       | E $\flat$ m       | Em       | Fm       |
| Cm7      | C#m7      | Dm7      | E $\flat$ m7      | Em7      | Fm7      |
| Cdim     | C#dim     | Ddim     | E $\flat$ dim     | Edim     | Fdim     |
| Cm7 (b5) | C#m7 (b5) | Dm7 (b5) | E $\flat$ m7 (b5) | Em7 (b5) | Fm7 (b5) |
| Caug     | C#aug     | Daug     | E $\flat$ aug     | Eaug     | Faug     |
| Csus4    | C#sus4    | Dsus4    | E $\flat$ sus4    | Esus4    | Fsus4    |
| C7sus4   | C#7sus4   | D7sus4   | E $\flat$ 7sus4   | E7sus4   | F7sus4   |
| C6       | C#6       | D6       | E $\flat$ 6       | E6       | F6       |
| Cm6      | C#m6      | Dm6      | E $\flat$ m6      | Em6      | Fm6      |

# Chord List

---

|           |          |                   |          |                   |          |
|-----------|----------|-------------------|----------|-------------------|----------|
| F#        | G        | A $\flat$         | A        | B $\flat$         | B        |
| F#M7      | GM7      | A $\flat$ M7      | AM7      | B $\flat$ M7      | BM7      |
| F#7       | G7       | A $\flat$ 7       | A7       | B $\flat$ 7       | B7       |
| F#m       | Gm       | A $\flat$ m       | Am       | B $\flat$ m       | Bm       |
| F#m7      | Gm7      | A $\flat$ m7      | Am7      | B $\flat$ m7      | Bm7      |
| F#dim     | Gdim     | A $\flat$ dim     | Adim     | B $\flat$ dim     | Bdim     |
| F#m7 (b5) | Gm7 (b5) | A $\flat$ m7 (b5) | Am7 (b5) | B $\flat$ m7 (b5) | Bm7 (b5) |
| F#aug     | Gaug     | A $\flat$ aug     | Aaug     | B $\flat$ aug     | Baug     |
| F#sus4    | Gsus4    | A $\flat$ sus4    | Asus4    | B $\flat$ sus4    | Bsus4    |
| F#7sus4   | G7sus4   | A $\flat$ 7sus4   | A7sus4   | B $\flat$ 7sus4   | B7sus4   |
| F#6       | G6       | A $\flat$ 6       | A6       | B $\flat$ 6       | B6       |
| F#m6      | Gm6      | A $\flat$ m6      | Am6      | B $\flat$ m6      | Bm6      |

# Settings That Are Stored After the Power Is Turned Off

## Settings That Are Stored After the Power Is Turned Off

---

### Function Menu

Metronome Sound

### Utility Menu

Registration Shift  
Registration Arranger Update  
Registration Transpose Update  
TX MIDI Channel (only the MIDI Output channel of the Control track)  
MIDI In Mode  
Send PC Switch  
Master Tune  
LCD Contrast

## Settings That Are Stored in the Registration Buttons

---

### Panel Settings

Registration Name  
Selected Rhythms for each Rhythm group button

### Utility Menu

Registration Shift  
Registration Arranger Update  
Registration Transpose Update

## Settings That Are Stored in the Individual Registration Buttons

---

### Panel Settings

[To Lower] button (ON/OFF)  
[Manual Drums] button (ON/OFF)  
The Voices assigned for each part  
The Reverb depth for each part  
The voices assigned to the [Others] buttons for each part  
[Harmony Intelligence] button (ON/OFF)  
Rotary [Fast/Slow] button (ON/OFF)  
Rhythm type  
[Intro/Ending] button (ON/OFF)  
[Sync Start] button (ON/OFF)  
[Advanced] button (ON/OFF)  
Part Balance [▲] [▼] buttons settings (Part Balance Volume)  
Rotary [ON/OFF] button (ON/OFF)  
Arranger [ON/OFF] button (ON/OFF)

Transpose setting  
Tempo setting

### Effect Menu

Reverb Type  
Sustain  
Sustain Length

### Utility Menu

Initial Touch ON/OFF  
Pedal Bass Mode  
Solo Mode  
Left Foot Switch Assignment  
Damper Pedal Assignment  
Manual Drums Set  
Harmony Intelligence Type  
Chord Intelligence (ON/OFF)  
Chord Hold (ON/OFF)  
Tx MIDI Channel (Upper, Lower, Pedal, Solo)  
PC Number (Bank Select)

# Glossary

## **Arrangement**

This refers to changes that have been made in an original tune, by adding a new accompaniment or by changing the instruments used.

## **Automatic Accompaniment**

Automatic Accompaniment is automatic accompaniment when just a few keys in the lower section of the keyboard are pressed to specify the chord.

## **Basic Chord**

This refers to the most commonly used types of chord, which are generally the following six types: major chords, minor chords, minor seventh chords, minor seventh (b5) chords, dominant seventh chords, and diminished seventh chords.

## **Chord**

Notes of two or more pitches sounded simultaneously. Chords consisting of three notes are called "triads," and are the most basic type of chord.

## **Ending**

This is the last part of the accompaniment. When you stop playing the Automatic Accompaniment, the AT-20R plays an Ending appropriate for the Rhythm.

## **Glide**

An effect that temporarily lowers the pitch and then gradually returns it to normal.

## **Intro**

This is the introductory portion of an Automatic Accompaniment performance. The AT-20R plays an intro ideally suited to each Rhythm when it starts playing the Automatic Accompaniment.

## **Inversion**

When the lowest note of a chord is the root, the chord is said to be in "root position." In contrast, forms of a chord in which other notes are the lowest pitch are called "inversions."

## **Mute**

To silence a sound. The AT-20R provides a Track Mute function that allows you to turn off the track button indicator of a track on which music data has been recorded, so that the corresponding track will temporarily be silenced.

## **Panel Settings**

Settings such as sound selections, tempo, Rotary fast/slow.

## **Registration**

A unit of data that contains the performance state of the instrument, such as sound selections and panel settings.

## **Reverb**

An effect that simulates the reverberation of a room or concert hall.

## **Root Note**

The root note is the basis of a chord. All chords are built on a root note, which is the part of the chord name given in uppercase letters.

## **Rotary**

An effect which simulates the modulation given to the sound when a rotating speaker is used. The Rotary effect produces two types of modulation: fast or slow.

## **Sustain**

An effect that adds a decay to each note. The AT-20R allows sustain to be applied to the voices of the upper part, lower part, and pedal part.

## **Voice**

The AT-20R is able to produce the sounds of various instruments. These sounds are called "Voices."

## About ATELIER Series Sound Generator

---

The ATELIER series come equipped with GM / GS sound generators.

### General GM System

The General MIDI system is a set of recommendations which seeks to provide a way to go beyond the limitations of proprietary designs, and standardize the MIDI capabilities of sound generating devices. Sound generating devices and music data that meets the General MIDI standard bears the General MIDI logo. Music data bearing the General MIDI logo can be played back using any General MIDI sound generating unit to produce essentially the same musical performance.

### GS format

The GS Format is Roland's set of specifications for standardizing the performance of sound generating devices. In addition to including support for everything defined by the General MIDI System, the highly-compatible GS Format additionally offers an expanded number of sounds, provides for the editing of sounds, and spells out many details for a wide range of extra features, including effects such as reverb and chorus.

Designed with the future in mind, the GS Format can readily include new sounds and support new hardware features when they arrive.

Since it is upwardly compatible with the General MIDI System, Roland's GS Format is capable of reliably playing back GM Scores equally as well as it performs GS Music Data (music data that has been created with the GS Format in mind).

This product supports both the General MIDI system and the GS format, and can be used to play back music data carrying either of these logos.

### MIDI Implementation Chart

| Function...                                                                                                                       | Transmitted                                                                                                                                                        | Recognized                                                                                   | Remarks                                                                                                  |                                                                                                                                                                                                                                             |
|-----------------------------------------------------------------------------------------------------------------------------------|--------------------------------------------------------------------------------------------------------------------------------------------------------------------|----------------------------------------------------------------------------------------------|----------------------------------------------------------------------------------------------------------|---------------------------------------------------------------------------------------------------------------------------------------------------------------------------------------------------------------------------------------------|
| Basic Channel<br>Default<br>Changed                                                                                               | 12 (Lower)<br>13 (Upper)<br>14 (Pedal Bass)<br>16 (Solo, Expression, PC)<br>1-16                                                                                   | 1-16<br>1-16<br>1-16<br>1-16<br>1-16                                                         |                                                                                                          |                                                                                                                                                                                                                                             |
| Mode<br>Default<br>Messages<br>Altered                                                                                            | x<br>x<br>*****                                                                                                                                                    | Mode 3<br>Mode 3, 4(M=1)                                                                     | * 3                                                                                                      |                                                                                                                                                                                                                                             |
| Note Number :<br>True Voice                                                                                                       | 36-96<br>*****                                                                                                                                                     | 0-127<br>0-127                                                                               |                                                                                                          |                                                                                                                                                                                                                                             |
| Velocity<br>Note ON<br>Note OFF                                                                                                   | O<br>x 8n v=64                                                                                                                                                     | *1<br>O<br>x                                                                                 |                                                                                                          |                                                                                                                                                                                                                                             |
| After Touch<br>Key's<br>Ch's                                                                                                      | x<br>x                                                                                                                                                             | O<br>O                                                                                       | *2<br>*2                                                                                                 |                                                                                                                                                                                                                                             |
| Pitch Bend                                                                                                                        | x                                                                                                                                                                  | O                                                                                            | *2                                                                                                       |                                                                                                                                                                                                                                             |
| Control Change<br>0, 32<br>1<br>5<br>6, 38<br>7<br>10<br>11<br>16<br>64<br>65<br>66<br>67<br>84<br>91<br>93<br>98, 99<br>100, 101 | O<br>x<br>x<br>x<br>x<br>x<br>O<br>x<br>x<br>x<br>x<br>x<br>x<br>x<br>x<br>x<br>x<br>x<br>x                                                                        | *1<br>O<br>O<br>O<br>O<br>O<br>O<br>O<br>O<br>O<br>O<br>O<br>O<br>O<br>O<br>O<br>O<br>O<br>O | *3<br>*2<br>*2<br>*2<br>*2<br>*3<br>*3<br>*4<br>*3<br>*3<br>*2<br>*2<br>*2<br>*3<br>*3<br>*3<br>*3<br>*2 | Bank select<br>Modulation<br>Portamento time<br>Data entry<br>Volume<br>Panpot<br>Expression<br>Glide<br>Hold 1<br>Portamento<br>Sostenuto<br>Soft<br>Portamento control<br>Effect1 depth<br>Effect3 depth<br>NRPN LSB, MSB<br>RPN LSB, MSB |
| Prog Change : True #                                                                                                              | 0-127<br>*****                                                                                                                                                     | *1<br>O<br>0-127                                                                             | *3<br>Program number 1-128                                                                               |                                                                                                                                                                                                                                             |
| System Exclusive                                                                                                                  | x                                                                                                                                                                  | O                                                                                            |                                                                                                          |                                                                                                                                                                                                                                             |
| System Common<br>: Song Pos<br>: Song Sel<br>: Tune                                                                               | x<br>x<br>x                                                                                                                                                        | x<br>x<br>x                                                                                  |                                                                                                          |                                                                                                                                                                                                                                             |
| System Real Time<br>: Clock<br>: Commands                                                                                         | O<br>O                                                                                                                                                             | x<br>x                                                                                       |                                                                                                          |                                                                                                                                                                                                                                             |
| Aux Message<br>: All sound off<br>: Reset all controllers<br>: Local Control<br>: All Notes OFF<br>: Active Sense<br>: Reset      | x<br>x<br>x<br>x<br>O<br>x                                                                                                                                         | O (120, 126, 127)<br>O<br>x<br>O (123-125)<br>O<br>x                                         |                                                                                                          |                                                                                                                                                                                                                                             |
| Notes                                                                                                                             | * 1 O x is selectable.<br>* 2 O x is selectable by SysEx.<br>* 3 Recognize only GS Part.<br>* 4 Recognize only Keyboard Part.<br>* 5 Recognize as M=1 even if M≠1. |                                                                                              |                                                                                                          |                                                                                                                                                                                                                                             |

Mode 1 : OMNI ON, POLY    Mode 2 : OMNI ON, MONO    O : Yes  
 Mode 3 : OMNI OFF, POLY    Mode 4 : OMNI OFF, MONO    X : No



# Main Specifications

## AT-20R:Music Atelier

### Keyboard

Upper 49 Keys Lower 61 Keys;  
Pedalboard 13 notes

### Voices (108 Voices)

#### Upper Organ:

Full, Jazz, Pipe etc.

#### Upper Orchestral:

Strings, Piano, Brass, Choir, Guitar etc.

#### Lower Organ:

Lower, Pipe etc.

#### Lower Orchestral:

Strings, Piano, Brass, Choir, Guitar etc.

#### Solo:

Trumpet, Sax, Flute etc.

#### Pedal Bass:

Organ1 etc.

\* Any one of the 108 voices (except the preset ones) can be assigned to each [Others] button.

### Rhythms (32 Rhythms, Variation/Original)

Big Band/Swing, Country, Oldies, Ballad, Acoustic, Latin1, Latin2, Pop, Waltz/March, Disk etc.

\* Music Style Disks (MSA series; sold separately) can provide additional Music Styles.

### Number of accompaniment/SMF play voices

226 Voices

### Number of Manual Drums sets

8 Sets

### Number of Sound Effects sets

1 Set

### Effects

Rotary Sound, Reverb, Sustain, Glide

### Harmony Intelligence

Traditional, Harp, Octave 1, Octave 2

### Arranger function

Arranger On/Off, Start/Stop, Intro/Ending, Sync Start, Fill In (Variation/Original), Advanced/Basic, One Touch Program, Break

### Number of Registration memories

4

### Composer

|                |                            |
|----------------|----------------------------|
| Tracks:        | 7                          |
| Note Storage : | approx. 40,000 notes       |
| Song Length:   | max. 999 measures          |
| Tempo:         | Quarter note = 20 to 250   |
| Resolution:    | 120 ticks per quarter note |
| Recording:     | Realtime                   |

### Storage: 3.5 inch micro floppy disk

#### Disk format:

720 K bytes (2DD), 1.44 M bytes (2HD)

#### Songs:

max. 56 (2DD), max. 99 (2HD)

### Rated power output

25 W x 2

### Speakers

#### Body:

full-range: 20 cm x 2

### Display

16 characters, 2 lines (backlit LCD)

### Disk drive

3.5 inch micro floppy disk drive (2DD/2HD)

### Pedals

Damper pedal  
Expression pedal  
Left foot switch (assignable)

### Connectors

Phones jack (Stereo)  
AC inlet  
Pedal jack  
MIDI connectors (In/Out)  
Audio output jacks (L(MONO)/R)  
Computer connector

## Main Specifications

---

### Power supply

AC 117 V, AC 230 V or AC 240 V

### Power consumption

80 W (AC 117 V)

65 W (AC 230 V)

65 W (AC 240 V)

### Finish

Traditional Walnut

### Dimensions

**Console** (Including music rest) :

1146 (W) x 567 (D) x 471 (H) mm

45-1/8 (W) x 22-3/8 (D) x 18-9/16 (H) inches

**Stand** (Including Pedalboard) :

1152 (W) x 515 (D) x 748 (H) mm

45-3/8 (W) x 20-5/16 (D) x 29-1/2 (H) inches

**Total** (Including music rest and Pedalboard) :

1152 (W) x 567 (D) x 1219 (H) mm

45-3/8 (W) x 22-3/8 (D) x 47-1 (H) inches

**Bench:**

600 (W) x 300 (D) x 600 (H) mm

23-5/8 (W) x 11-13/16 (D) x 23-5/8 (H) inches

**Weight**

Console: 39.3 kg / 86 lbs 11 oz

Stand: 24.0 kg / 52 lbs 15 oz

Total: 63.3 kg / 139 lbs 9 oz

Bench: 6.3 kg / 13 lbs 15 oz

### Accessories

Bench

Owner's manual

3.5 inch micro floppy disk (2HD) (Blank Disk)

Music style disk

Power Cord

\* In the interest of product improvement, the specifications and/or appearance of this unit are subject to change without prior notice.

# Index

- A**  
Arrangement .....33  
Arranger .....34–35  
Automatic Accompaniment .....34–35
- B**  
Basic Pitch .....95  
Basic Screen .....16  
Bass Pedalboard .....19  
Bass To Lower .....44  
Beat .....79  
Beat Indicator .....34  
Break .....91
- C**  
Chord .....34  
Chord Hold .....92  
Composer .....57, 78  
Composer Screen .....16  
Computer .....97  
Copy  
    Measure .....85  
Copying  
    Name of Registration .....52  
Count-In .....58  
Count-In Recording .....78
- D**  
Damper Pedal .....46, 91  
Delete  
    Measure .....82  
    Track .....83  
Deleting  
    Registration .....56  
Demo Song .....17  
Disk Drive .....37  
Display of Lyrics .....81  
Drum Set .....28
- E**  
Eject Button .....37  
Ending .....32, 91  
Erase  
    Portion of Performance Data .....84  
Erasing  
    Performance Song .....63  
    Performance Songs on Floppy Disk .....73  
Expression Pedal .....46  
    Function .....79
- F**  
Factory Default Settings .....16  
Factory Reset .....16  
Fill In  
    Fill In To Original .....33, 91  
    Fill In To Variation .....33, 91  
Floppy Disk .....37  
    Format .....64  
Foot Switch .....47, 90  
    Format .....64
- G**  
Glide .....91
- H**  
Harmony Intelligence .....40, 92  
Headphones .....15
- I**  
Initial Touch .....89  
Intro .....31, 91
- L**  
LCD Contrast .....95  
Leading Bass .....91  
Loading  
    Disk Rhythm .....38  
    Performance Song .....70  
    Registration .....54  
Loop Recording .....76  
Lower Keyboard .....19  
Lower Voice .....20
- M**  
Manual Drum Set .....29, 92  
Manual Drums .....28  
Master  
    Volume .....46  
Master Tuning .....95  
Metronome .....78  
    Sound .....78  
    Volume .....78  
MIDI .....97  
MIDI Output Channel .....93  
Music Style Disk .....37  
Muting  
    Channel .....80
- N**  
Name  
    Performance Song .....66
- O**  
Octave Shift .....27  
One Touch Program .....35
- P**  
Panel Settings .....36  
Part .....19  
PC Number .....94  
Pedal .....46  
Pedal Bass Voice .....20, 22  
    How the Bass Pedalboard Can Be Played .....90

## Index

---

|                                       |    |
|---------------------------------------|----|
| Playing                               |    |
| Demo Song .....                       | 17 |
| Performance Song .....                | 60 |
| Performance Song on Floppy Disk ..... | 72 |
| Punch-in Recording .....              | 74 |

|                |    |
|----------------|----|
| <b>Q</b>       |    |
| Quantize ..... | 86 |

|                             |           |
|-----------------------------|-----------|
| <b>R</b>                    |           |
| Recording .....             | 58–59, 62 |
| Registration .....          | 48        |
| Assigning a Name .....      | 50        |
| Copying the Name .....      | 52        |
| Delete .....                | 56        |
| Load .....                  | 54        |
| Recall .....                | 49        |
| Recall Timing .....         | 93        |
| Save .....                  | 53        |
| Store .....                 | 48        |
| Reverb Effect .....         | 43        |
| Reverb Depth .....          | 88        |
| Reverb Type .....           | 87        |
| Rhythm .....                | 30        |
| Arrangement .....           | 33        |
| Ending .....                | 32        |
| Fill In .....               | 33        |
| Intro .....                 | 31        |
| Starting and Stopping ..... | 31, 91    |
| Rhythm Screen .....         | 16        |
| Rotary Effect .....         | 42        |

|                                              |        |
|----------------------------------------------|--------|
| <b>S</b>                                     |        |
| Saving                                       |        |
| Performance Song .....                       | 67     |
| Registration .....                           | 53     |
| SMF .....                                    | 67     |
| SMF Format .....                             | 69     |
| SMF                                          |        |
| Track Assignment .....                       | 61     |
| SMF Format .....                             | 71–72  |
| Save .....                                   | 69     |
| SMF Song File .....                          | 72     |
| Solo Voice .....                             | 23     |
| Changing How the Solo Voice Will Sound ..... | 90     |
| Sound Effect .....                           | 28     |
| Sustain Effect .....                         | 43, 88 |
| Sustain Length .....                         | 88     |
| Sync Start .....                             | 31, 35 |

|                  |    |
|------------------|----|
| <b>T</b>         |    |
| Tempo .....      | 34 |
| Track .....      | 57 |
| Track Mute ..... | 61 |
| Transpose .....  | 45 |

|                      |    |
|----------------------|----|
| <b>U</b>             |    |
| Upper Keyboard ..... | 19 |
| Upper Voice .....    | 20 |

|                      |    |
|----------------------|----|
| <b>V</b>             |    |
| Volume               |    |
| Master .....         | 14 |
| Metronome .....      | 78 |
| Volume Balance ..... | 26 |

# Demo Song List

To play the Demo Songs, please refer to "Listening to the Demo Songs" (p. 17).

## ■ AT-20R

| Song Title   | Composer       | Player         | Copyright                      |
|--------------|----------------|----------------|--------------------------------|
| Big Band     | Ric Iannone    | Ric Iannone    | © 1999 Roland Corporation      |
| Jazz Scat    | Ric Iannone    | Ric Iannone    | © 1999 Roland Corporation      |
| TheaterOrgan | Jonas Nordwall | Jonas Nordwall | © 1995 Rodgers Instruments LLC |

\* All rights reserved. Unauthorized use of this material for purposes other than private, personal enjoyment is a violation of applicable laws.

\* The data for the Demo song that is being played is not available at the MIDI Out connector.

## ■ Profile

### Hector Olivera

Hector Olivera was born in Argentina. He received his education at the Conservatory and the University of Buenos Aires followed by a scholarship at the famous Juilliard School of Music in New York. Olivera has performed extensively throughout the world including concerts at prestigious places such as the Notre Dame Cathedral in Paris and Carnegie Hall in New York. Hector Olivera's expertise involves both the traditional pipe organ and the electronic organ. Presently Olivera tours internationally playing some of the world's most magnificent pipe organs as well as his preferred electronic organ, the Roland Atelier for which he continues to collaborate with its development.

### Jonas Nordwall

A native of Portland, Mr. Nordwall received his Bachelor of Music Degree in 1970 from the University of Portland studying with Arthur Hitchcock. Additional study was done with Frederick Geoghegan, the noted English/Canadian organist. As a teenager, Jonas had the privilege to study with Richard Ellsasser, one of the greatest virtuoso organist of this century.

Besides serving as Director of Music for the First United Methodist Church in Portland, Oregon and as the Organist for the Oregon Symphony Orchestra.

He has been a featured recitalist for national conventions of the American Theatre Organ Society and was Organist of the year for 1987.

### Ric Iannone

Ric Iannone began playing the piano and accordion at the age of two and a half. By the time he was seven, he was performing public and private engagements with his musician father. For more than 20 years Ric has performed and traveled extensively throughout the United States and Europe, delighting audiences with his unique playing style and music arrangements. He is equally comfortable playing the organ, piano or keyboard, as a concert artist and product demonstrator.

# Information

When you need repair service, call your nearest Roland Service Center or authorized Roland distributor in your country as shown below.

## AFRICA

### EGYPT

Al Fanny Trading Office  
P.O. Box 2904,  
El Horrieh Heliopolis, Cairo,  
EGYPT  
TEL: (02) 4185531

### REUNION

Maison FO - YAM Marcel  
25 Rue Jules MermetZL  
Chaudron - BP79 97491  
Ste Clotilde REUNION  
TEL: 28 29 16

### SOUTH AFRICA

That Other Music Shop  
(PTY) Ltd.  
11 Melle Street (Cnr Melle and  
Juta Street)  
Braamfontein 2001  
Republic of SOUTH AFRICA  
TEL: (011) 403 4105

Paul Bothner (PTY) Ltd.  
17 Werdmuller Centre Claremont  
7700  
Republic of SOUTH AFRICA

P.O. Box 23032  
Claremont, Cape Town  
SOUTH AFRICA, 7735  
TEL: (021) 64 4030

## ASIA

### CHINA

Beijing Xinghai Musical  
Instruments Co., Ltd.  
6 Huangnuchang Chao Yang  
District, Beijing, CHINA  
TEL: (010) 6774 7491

### HONG KONG

Tom Lee Music Co., Ltd.  
Service Division  
22-32 Pun Shan Street, Tsuen  
Wan, New Territories,  
HONG KONG  
TEL: 2415 0911

### INDIA

Rivera Digitec (India) Pvt. Ltd.  
409, Nirman Kendra Mahalaxmi  
Flats, Compound  
off. Dr. Edwin Moses Road,  
Mumbai 400011, INDIA  
TEL: (022) 498 3079

### INDONESIA

PT Galestra Inti  
Kompleks Perkantoran  
Duta Merlin Blok E No.6—7  
Jl. Gajah Mada No.3—5,  
Jakarta 10130,  
INDONESIA  
TEL: (021) 6335416

### KOREA

Cosmos Corporation  
Service Station  
261 2nd Floor Nak-Won Arcade  
Jong-Ro ku, Seoul, KOREA  
TEL: (02) 742 8844

### MALAYSIA

Bentley Music SDN BHD  
140 & 142, Jalan Bukit Bintang  
55100 Kuala Lumpur, MALAYSIA  
TEL: (03) 2443333

### PHILIPPINES

G.A. Yupangco & Co. Inc.  
339 Gil J. Puyat Avenue  
Makati, Metro Manila 1200,  
PHILIPPINES  
TEL: (02) 899 9801

### SINGAPORE

Swee Lee Company  
150 Sims Drive,  
SINGAPORE 387381  
TEL: 748-1669

### CRISTOFORI MUSIC PTE LTD

Blk 3014, Bedok Industrial Park E,  
#02-2148, SINGAPORE 489980  
TEL: 243 9555

### TAIWAN

ROLAND TAIWAN  
ENTERPRISE CO., LTD.  
Room 5, 9th. No. 112 Chung Shan  
N.Road Sec.2, Taipei, TAIWAN,  
R.O.C.  
TEL: (02) 2561 3339

### THAILAND

Theera Music Co., Ltd.  
330 Veeng NakornKasem, Soi 2,  
Bangkok 10100, THAILAND  
TEL: (02) 2248821

### VIETNAM

Saigon Music  
138 Tran Quang Khai St.,  
District 1  
Ho chi minh City  
VIETNAM  
TEL: (8) 844 4068

## AUSTRALIA/ NEW ZEALAND

### AUSTRALIA

Roland Corporation  
Australia Pty. Ltd.  
38 Campbell Avenue  
Dee Why West, NSW 2099  
AUSTRALIA  
TEL: (02) 9982 8266

### NEW ZEALAND

Roland Corporation (NZ) Ltd.  
97 Mt. Eden Road, Mt. Eden,  
Auckland 3, NEW ZEALAND  
TEL: (09) 3098 715

## CENTRAL/LATIN AMERICA

### ARGENTINA

Instrumentos Musicales S.A.  
Florida 656 2nd Floor  
Office Number 206A  
Buenos Aires  
ARGENTINA, CP1005  
TEL: (54-11) 4- 393-6057

### BRAZIL

Roland Brasil Ltda.  
R. Coronel Octaviano da Silveira  
203 05522-010  
Sao Paulo BRAZIL  
TEL: (011) 843 9377

### CHILE

Comercial Fancy S.A.  
Avenida Rancagua #0330  
Providencia Santiago, CHILE  
TEL: 56-2-373-9100

### EL SALVADOR

OMNI MUSIC  
75 Avenida Notre y Alameda  
Juan Pablo 2 No. 4010  
San Salvador, EL SALVADOR  
TEL: (503) 262-0788

### MEXICO

Casa Veerkamp, s.a. de c.v.  
Av. Toluca No. 323 Col. Olivar de  
los Padres 01780 Mexico D.F.  
MEXICO  
TEL: (525) 668 04 80

### La Casa Wagner de

Guadalajara s.a. de c.v.  
Av. Corona No. 202 S.J.  
Guadalajara, Jalisco Mexico  
C.P.41100 MEXICO  
TEL: (03) 613 1414

### PANAMA

Productos Superiores, S.A.  
Apartado 655 - Panama 1  
REP. DE PANAMA  
TEL: (507) 270-2200

### URUGUAY

Todo Musica  
Cuareim 1488, Montevideo,  
URUGUAY  
TEL: 5982-924-2335

### VENEZUELA

Musicland Digital C.A.  
Av. Francisco de Miranda,  
Centro Parque de Cristal, Nivel  
C2 Local 20 Caracas  
VENEZUELA  
TEL: (02) 285 9218

## EUROPE

### AUSTRIA

Roland Austria GES.M.B.H.  
Siemensstrasse 4, P.O. Box 74,  
A-6063 RUM, AUSTRIA  
TEL: (0512) 26 44 260

### BELGIUM/HOLLAND/ LUXEMBOURG

Roland Benelux N. V.  
Houtstraat 3 B-2260 Oevel  
(Westerlo) BELGIUM  
TEL: (014) 575811

### DENMARK

Roland Scandinavia A/S  
Langebrogade 6 Post Box 1937  
DK-1023 Copenhagen K,  
DENMARK  
TEL: 32 95 3111

### FRANCE

Roland France SA  
4, Rue Paul Henri SPAAK  
Parc de l'Espérance F 77 462 St.  
Thibault Lagny Cedex FRANCE  
TEL: 01 600 73 500

### FINLAND

Roland Scandinavia As,  
Filial Finland  
Lauttasaarentie 54 B  
Fin-00201 Helsinki, FINLAND  
TEL: (9) 682 4020

### GERMANY

Roland Elektronische  
Musikinstrumente  
Handelsgesellschaft mbH.  
Oststrasse 96, 22844 Norderstedt,  
GERMANY  
TEL: (040) 52 60090

### GREECE

V. Dimitriadis & Co. Ltd.  
20, Alexandras St. & Bouboulinas  
54 St. 106 82 Athens, GREECE  
TEL: (01) 8227 775

### HUNGARY

Intermusica Ltd.  
Warehouse Area 'DEPO' Pl.83  
H-2046 Torokbalint, HUNGARY  
TEL: (23) 511011

### IRELAND

Roland Ireland  
Audio House, Belmont Court,  
Donnybrook, Dublin 4,  
Republic of IRELAND  
TEL: (01) 2603501

### ITALY

Roland Italy S. p. A.  
Viale delle Industrie, 8  
20020 Arese Milano, ITALY  
TEL: (02) 937-78300

### NORWAY

Roland Scandinavia Avd.  
Kontor Norge  
Lilleakerveien 2 Postboks 95  
Lilleaker N-0216 Oslo  
NORWAY  
TEL: 273 0074

### POLAND

P. P. H. Brzostowicz  
UL. Gibraltarska 4,  
PL-03664 Warszawa POLAND  
TEL: (022) 679 44 19

### PORTUGAL

Tecnologias Musica e Audio,  
Roland Portugal, S.A.  
RUA SANTA CATERINA  
131 - 4000 Porto -PORTUGAL  
TEL: (02) 208 44 56

### ROMANIA

FBS LINES  
Plata Libertatii 1,  
RO-4200 Cheorgheni  
TEL: (066) 164-609

### RUSSIA

Slami Music Company  
Sadjajava-Triumfalnaja st., 16  
103006 Moscow, RUSSIA  
TEL: 095 209 2193

### SPAIN

Roland Electronics  
de España, S. A.  
Calle Bolivia 239 08020 Barcelona,  
SPAIN  
TEL: (93) 308 1000

### SWEDEN

Roland Scandinavia A/S  
SWEDISH SALES OFFICE  
Danvik Center 28, 2 tr.  
S-131 30 Nacka SWEDEN  
TEL: (08) 702 0020

### SWITZERLAND

Roland (Switzerland) AG  
Musitronic AG  
Gerberstrasse 5, CH-4410 Liestal,  
SWITZERLAND  
TEL: (061) 921 1615

### UKRAINE

TIC-TAC  
Mira Str. 19/108  
P.O. Box 180  
295400 Mukachevo, UKRAINE  
TEL: (03131) 414-40

### UNITED KINGDOM

Roland (U.K.) Ltd.  
Atlantic Close, Swansea  
Enterprise Park SWANSEA  
SA7 9FL,  
UNITED KINGDOM  
TEL: (01792) 700139

## MIDDLE EAST

### BAHRAIN

Moon Stores  
Bab Al Bahrain Road,  
P.O. Box 20077  
State of BAHRAIN  
TEL: 211 005

### CYPRUS

Radex Sound Equipment Ltd.  
17 Diagonou St., P.O. Box 2046,  
Nicosia CYPRUS  
TEL: (02) 453 426

### ISRAEL

Halilit P. Greenspoon &  
Sons Ltd.  
8 Retziy Fa aliya Hashnya St.  
Tel-Aviv-Yaho ISRAEL  
TEL: (03) 6823666

### JORDAN

AMMAN Trading Agency  
Prince Mohammed St. P.O. Box  
825 Amman 11118 JORDAN  
TEL: (06) 4641200

### KUWAIT

Easa Husain Al-Yousifi  
P.O. Box 126 Safat 13002  
KUWAIT  
TEL: 5719499

### LEBANON

A. Chahine & Fils  
P.O. Box 16-8857 Gergi Zeidan St.  
Chahine Building, Achrafieh  
Beirut, LEBANON  
TEL: (01) 335799

### OMAN

OHI Electronics & Trading  
Co. LLC  
P.O. Box 889 Muscat  
Sultanate of OMAN  
TEL: 959085

### QATAR

Badie Studio & Stores  
P.O. Box 62,  
DOHA QATAR  
TEL: 423554

### SAUDI ARABIA

aDawlah Universal  
Electronics APL  
P.O. Box 2154 ALKHOBAR 31952,  
SAUDI ARABIA  
TEL: (03) 898 2081

### SYRIA

Technical Light & Sound  
Center  
Khaled Ibn Al Walid St.  
P.O. Box 13520  
Damascus - SYRIA  
TEL: (011) 2235 384

### TURKEY

Barkat Muzik aletleri ithalat  
ve ihracat limited ireketi  
Siraselvier Cad. Guney Ishani No.  
86/6 Taksim, Istanbul TURKEY  
TEL: (0212) 2499324

### U.A.E.

Zak Electronics & Musical  
Instruments Co.  
Zabeel Road, Al Sherooq Bldg.,  
No. 14, Grand Floor DUBAI  
U.A.E.  
P.O. Box 8050 DUBAI, U.A.E.  
TEL: (04) 360715

## NORTH AMERICA

### CANADA

Roland Canada Music Ltd.  
(Head Office)  
5480 Parkwood Way Richmond  
B. C., V6V 2M4 CANADA  
TEL: (0604) 270 6626

### Roland Canada Music Ltd.

(Toronto Office)  
Unit 2, 109 Woodbine Downs  
Blvd, Etobicoke, ON  
M9W 6Y1 CANADA  
TEL: (0416) 213 9707

### U. S. A.

Roland Corporation U.S.  
7200 Dominion Circle  
Los Angeles, CA. 90040-3696,  
U. S. A.  
TEL: (0323) 685 5141

# Corrections

We apologize for the following errors in the Owner's Manual for AT-20R. Please make the appropriate corrections.

## ■ Foot Switch

### ● Page 10 Contents

|                                                                                             |    |
|---------------------------------------------------------------------------------------------|----|
| Regist Shift (Use the <u>Left Foot Switch</u> to Switch Through Registration Buttons) ..... | 90 |
| <u>Left Foot Switch Assignment</u> .....                                                    | 90 |

### ● Page 15, 46 and 47 Figures of Foot Switch

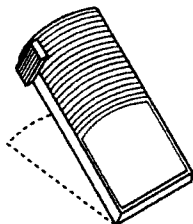

### ● Page 33 MEMO

The functions of the [Start/Stop] button, the [To Variation] button, the [To Original] button and [Advanced] button can be assigned to the foot switch located on the left side of the Expression Pedal (p. 90).

### ● Page 42 MEMO

You can assign the Rotary Sound [Fast/Slow] button function to the foot switch located on the left side of the Expression Pedal (p. 90).

### ● Page 47

The instrument is provided with a Foot Switch, one on left side of the Expression Pedal. You can switch between Fast/Slow for the Rotary effect by pushing the left switch with your foot.

With the factory settings, the following function is assigned to the left Foot Switch.

**Left Foot Switch**                      Switch the Rotary effect between Fast / Slow

### ● Page 47 Step 1

1. Press the Foot Switch toward the left.

### ● Page 47 MEMO

You can also change the function assigned to the left Foot Switch. Please refer to "Left Foot Switch Assignment" (p. 90).

### ● Page 47 NOTE

If the Utility menu item Registration Shift is ON, the left Foot Switch will be dedicated to switching through the Registration buttons (p. 90).

### ● Page 58 MEMO

The Play and Stop functions can both be assigned to the foot switch located on left side of the Expression Pedal. Each touch of the switch will alternate the operation between the Play and Stop functions (p. 90).

### ● Page 60 MEMO

The Play and Stop functions can be assigned to the foot switch located on left side of the Expression Pedal. Each touch of the switch will alternate the operation between the Play and Stop functions (p. 90).

### ● Page 89 List of Utility menu

.....  
Registration Shift

Using the left Foot Switch to switch registrations

.....  
**Left Foot Switch Assignment**

Selecting function for left Foot Switch  
.....

● **Page 90 Subtitle and body**

Registration Shift (Use the Left Foot Switch to Switch Through Registration Buttons)

You can use the left Foot Switch as a dedicated switch for selecting registrations in order.

If Registration Shift is turned ON, each time you press the left Foot Switch, the registrations will be selected in the following order: 1 → 2 → 3 → ... → 12 → 1 → .. etc.

● **Page 90 Subtitle and body**

Left Foot Switch Assignment

You can select any of the following functions and assign them to Foot Switch on the left side of the Expression Pedal.

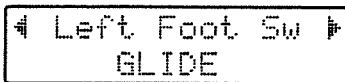

● **Page 91 The sentence below the list**

\* If the Utility menu "Registration Shift" setting is "ON", the left Foot Switch will be dedicated to switching through the Registrations, and the "Left Foot Switch Assignment" setting will be ignored.

● **Page 99 Troubleshooting**

**Can't use the function assigned to the left foot switch**

○ If the Utility menu item "Registration Shift" (change Registrations) is ON (p. 90), the left Foot Switch will be dedicated to switching the Registration.

● **Page 109 Utility Menu, Settings That Are Stored in the Individual Registration Buttons**

Left Foot Switch Assignment

■ **Rear Panel**

● **Page 13, 96 and 98 Figures of rear panel**

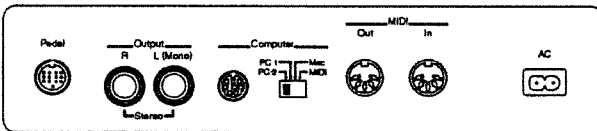

● **Page 97 and 98 Figures of Computer switch**

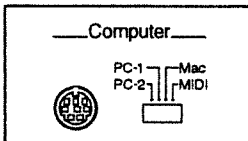

■ **Others**

● **Page 89 The sentence below Step 4**

To return to the basic screen, press the [Utility] button or the [Display/Exit] button.



# Demo Song List

To play the Demo Songs, please refer to Owner's Manual "Listening to the Demo Songs."

## AT-90R

| Song Title    | Composer       | Player         | Copyright                      |
|---------------|----------------|----------------|--------------------------------|
| Orchestra     | Hector Olivera | Hector Olivera | © 1999 Roland Corporation      |
| Pipe Organ    | Hector Olivera | Hector Olivera | © 1999 Roland Corporation      |
| Big Band      | Ric Iannone    | Ric Iannone    | © 1999 Roland Corporation      |
| Theater Organ | Jonas Nordwall | Jonas Nordwall | © 1995 Rodgers Instruments LLC |
| Jazz Scat     | Ric Iannone    | Ric Iannone    | © 1999 Roland Corporation      |
| Choir         | Hector Olivera | Hector Olivera | © 1999 Roland Corporation      |
| Soprano       | Rachmaninov S. | Hector Olivera | © 1999 Roland Corporation      |
| Gregorian     | Ric Iannone    | Ric Iannone    | © 1999 Roland Corporation      |
| Tenor         | Ric Iannone    | Ric Iannone    | © 1999 Roland Corporation      |

## AT-30R

| Song Title    | Composer       | Player         | Copyright                      |
|---------------|----------------|----------------|--------------------------------|
| Big Band      | Ric Iannone    | Ric Iannone    | © 1999 Roland Corporation      |
| Jazz Scat     | Ric Iannone    | Ric Iannone    | © 1999 Roland Corporation      |
| Theater Organ | Jonas Nordwall | Jonas Nordwall | © 1995 Rodgers Instruments LLC |
| Gregorian     | Ric Iannone    | Ric Iannone    | © 1999 Roland Corporation      |

## AT-20R

| Song Title    | Composer       | Player         | Copyright                      |
|---------------|----------------|----------------|--------------------------------|
| Big Band      | Ric Iannone    | Ric Iannone    | © 1999 Roland Corporation      |
| Jazz Scat     | Ric Iannone    | Ric Iannone    | © 1999 Roland Corporation      |
| Theater Organ | Jonas Nordwall | Jonas Nordwall | © 1995 Rodgers Instruments LLC |

\* All rights reserved. Unauthorized use of this material for purposes other than private, personal enjoyment is a violation of applicable laws.

\* The data for the Demo song that is being played is not available at the MIDI Out connector.

## ■ Profile

### Hector Olivera

Hector Olivera was born in Argentina. He received his education at the Conservatory and the University of Buenos Aires followed by a scholarship at the famous Juilliard School of Music in New York. Olivera has performed extensively throughout the world including concerts at prestigious places such as the Notre Dame Cathedral in Paris and Carnegie Hall in New York. Hector Olivera's expertise involves both the traditional pipe organ and the electronic organ. Presently Olivera tours internationally playing some of the world's most magnificent pipe organs as well as his preferred electronic organ, the Roland Atelier for which he continues to collaborate with its development.

### Jonas Nordwall

A native of Portland, Mr. Nordwall received his Bachelor of Music Degree in 1970 from the University of Portland studying with Arthur Hitchcock. Additional study was done with Frederick Geoghegan, the noted English/Canadian organist. As a teenager, Jonas had the privilege to study with Richard Ellsasser, one of the greatest virtuoso organist of this century.

Besides serving as Director of Music for the First United Methodist Church in Portland, Oregon and as the Organist for the Oregon Symphony Orchestra.

He has been a featured recitalist for national conventions of the American Theatre Organ Society and was Organist of the year for 1987.

### Ric Iannone

Ric Iannone began playing the piano and accordion at the age of two and a half. By the time he was seven, he was performing public and private engagements with his musician father. For more than 20 years Ric has performed and traveled extensively throughout the United States and Europe, delighting audiences with his unique playing style and music arrangements. He is equally comfortable playing the organ, piano or keyboard, as a concert artist and product demonstrator.

# デモ曲一覧

デモ曲の再生については、取扱説明書「デモ曲を聴く」をご覧ください。

## AT-90R

| 曲名           | 作曲者            | 演奏者            | Copyright                      |
|--------------|----------------|----------------|--------------------------------|
| Orchestra    | Hector Olivera | Hector Olivera | © 1999 Roland Corporation      |
| Pipe Organ   | Hector Olivera | Hector Olivera | © 1999 Roland Corporation      |
| Big Band     | Ric Iannone    | Ric Iannone    | © 1999 Roland Corporation      |
| TheaterOrgan | Jonas Nordwall | Jonas Nordwall | © 1995 Rodgers Instruments LLC |
| Jazz Scat    | Ric Iannone    | Ric Iannone    | © 1999 Roland Corporation      |
| Choir        | Hector Olivera | Hector Olivera | © 1999 Roland Corporation      |
| Soprano      | Rachmaninov S. | Hector Olivera | © 1999 Roland Corporation      |
| Gregorian    | Ric Iannone    | Ric Iannone    | © 1999 Roland Corporation      |
| Tenor        | Ric Iannone    | Ric Iannone    | © 1999 Roland Corporation      |

## AT-30R

| 曲名           | 作曲者            | 演奏者            | Copyright                      |
|--------------|----------------|----------------|--------------------------------|
| Big Band     | Ric Iannone    | Ric Iannone    | © 1999 Roland Corporation      |
| Jazz Scat    | Ric Iannone    | Ric Iannone    | © 1999 Roland Corporation      |
| TheaterOrgan | Jonas Nordwall | Jonas Nordwall | © 1995 Rodgers Instruments LLC |
| Gregorian    | Ric Iannone    | Ric Iannone    | © 1999 Roland Corporation      |

## AT-20R

| 曲名           | 作曲者            | 演奏者            | Copyright                      |
|--------------|----------------|----------------|--------------------------------|
| Big Band     | Ric Iannone    | Ric Iannone    | © 1999 Roland Corporation      |
| Jazz Scat    | Ric Iannone    | Ric Iannone    | © 1999 Roland Corporation      |
| TheaterOrgan | Jonas Nordwall | Jonas Nordwall | © 1995 Rodgers Instruments LLC |

※ デモ曲を個人で楽しむ以外に権利者の許諾なく使用することは、法律で禁じられています。

※ デモ曲の演奏データはMIDI Out端子からは出力されません。

## ■ 作曲者プロフィール

### ヘクター・オリベラ (Hector Olivera)

アルゼンチン生まれ。ブエノスアイレス音楽院、ブエノスアイレス大学で学んだ後、ニューヨークのジュリアード音楽院の奨学生となる。その後、ノートルダム大聖堂やニューヨークのカーネギー・ホール等の一流会場でのコンサートも含め、世界中で精力的な演奏活動を行ってきた。彼は、伝統的なパイプオルガンだけでなく、電子オルガンの優れた演奏家でもある。現在は、世界でも有数な教会でのパイプオルガン演奏だけでなく、電子オルガンも好んで演奏し、国際的な演奏活動を展開する一方、ローランド・オルガン、ミュージック・アトリエの製品開発にも協力している。

### ジョナス・ノードウェル (Jonas Nordwall)

1970年、ポートランド大学でアーサー・ヒッチコックに師事し、音楽学士を取得。加えて、世界的に著名なオルガニスト、フレドリック・ジョーガンにも師事。また、10代にしてオルガニストとして今世紀最高の巨匠リチャード・エルセイザーに師事した経験を持つ。現在、オレゴン州ポートランドのユナイテッド・メソジスト教会の音楽主事を努める一方、オレゴン・シンフォニー・オーケストラのオルガン奏者としても活躍中。また、リサイタル楽器としてシアター・オルガンの人気を復興させた功労者の1人として、1987年にはオルガニスト・オブ・ジ・イヤーに選出される。パイプ・オルガンや電子オルガンの設計から演奏まで精力的に活動を続ける彼は、まさに才能を持つオルガン奏者の1人である。

### リック・イアノニ (Ric Iannone)

リック・イアノニは2才半でピアノとアコーディオンを始め、7才までは公私にわたり、音楽家の父と共演していた。これまで20年間以上、合衆国やヨーロッパで精力的に演奏活動を行っており、彼のユニークな演奏と編曲は、常に聴衆を魅了してきた。コンサート・アーティストとして、また製品スペシャリストとして、オルガン、ピアノ、キーボードなどの心地よい演奏は高い評価を得ている。現在は、さまざまな講習会で教育、アレンジ、指導をこなす傍ら、彼が経営するIM MusicでGMソフトウェアの制作を手がけている。

## Rhythm List

| No. | Name         | No. | Name         | No. | Name         |
|-----|--------------|-----|--------------|-----|--------------|
| 01  | BigBndBalld2 | 26  | Miami        | 51  | Folk Waltz   |
| 02  | Boogie       | 27  | Merenge      | 52  | Slow Waltz 2 |
| 03  | Jazz Band    | 28  | Reggae       | 53  | Swing Waltz  |
| 04  | Blues 2      | 29  | Tequila      | 54  | March 2/4    |
| 05  | Blues 3      | 30  | Hawaiian 2   | 55  | D Marsch 6/8 |
| 06  | Big Band 4   | 31  | Bossa Nova 2 | 56  | R&B 2        |
| 07  | Swing        | 32  | FastBosaNova | 57  | Rock'n'Roll2 |
| 08  | MidiumSwing2 | 33  | Bossa Nova 5 | 58  | Rock'n'Roll3 |
| 09  | Slow Swing 2 | 34  | Chacha 3     | 59  | Contemp 1    |
| 10  | Bluegrass 1  | 35  | Salsa 2      | 60  | Contemp 2    |
| 11  | Bluegrass 2  | 36  | Mambo 2      | 61  | Funk 1       |
| 12  | Cajun        | 37  | Samba 2      | 62  | Dance Pop 2  |
| 13  | Slow Country | 38  | Tango 4      |     |              |
| 14  | ContryBallad | 39  | Beguine 2    |     |              |
| 15  | CountrySwing | 40  | Easy Listen3 |     |              |
| 16  | Two Step 2   | 41  | Easy Listen4 |     |              |
| 17  | Train Beat   | 42  | Easy Listen5 |     |              |
| 18  | Twist 2      | 43  | Easy Listen6 |     |              |
| 19  | Slow Rock 2  | 44  | Easy Listen7 |     |              |
| 20  | Baroque      | 45  | Pop Piano    |     |              |
| 21  | Classic      | 46  | ShufflePop 1 |     |              |
| 22  | Charleston   | 47  | Gospel 2     |     |              |
| 23  | Dixieland 2  | 48  | GospelBallad |     |              |
| 24  | Foxtrot      | 49  | French Waltz |     |              |
| 25  | Macarena     | 50  | Vienna Waltz |     |              |





## **Voice/Rhythm List**

**ボイス／リズム対応表**

# Voice List

| AT-R<br>Voice No. | Tone Name    | AT-90R/<br>AT-80R | AT-60R | AT-30R | AT-20R | AT-90/AT-80<br>Voice No. | AT-30<br>Voice No. |
|-------------------|--------------|-------------------|--------|--------|--------|--------------------------|--------------------|
| A11               | Full Organ1  | o                 | o      | o      | o      | 001                      | 001                |
| A12               | Full Organ2  | o                 | o      | o      | o      | 003                      | 003                |
| A13               | Full Organ3  | o                 | o      | o      | o      | 005                      | 005                |
| A14               | Full Organ4  | o                 | o      | o      | o      | 002                      | 002                |
| A15               | Full Organ5  | o                 | o      | o      | o      | 004                      | 004                |
| A16               | Full Organ6  | o                 | o      | o      | o      | 006                      | 006                |
| A17               | Full Organ7  | o                 | o      | o      | -      | 033                      | 033                |
| A18               | Full Organ8  | o                 | -      | -      | -      | -                        | -                  |
| A19               | Full Organ9  | o                 | -      | -      | -      | -                        | -                  |
| B11               | Jazz Organ1  | o                 | o      | o      | o      | 007                      | 007                |
| B12               | Jazz Organ2  | o                 | o      | o      | o      | 009                      | 009                |
| B13               | Jazz Organ3  | o                 | o      | o      | o      | 011                      | 011                |
| B14               | Jazz Organ4  | o                 | o      | o      | o      | 008                      | 008                |
| B15               | Jazz Organ5  | o                 | o      | o      | o      | 010                      | 010                |
| B16               | Jazz Organ6  | o                 | o      | o      | o      | 012                      | 012                |
| B21               | Rock Organ1  | o                 | o      | o      | o      | 013                      | 013                |
| B22               | Rock Organ2  | o                 | o      | o      | o      | 014                      | 014                |
| C11               | Lower Organ1 | o                 | o      | o      | o      | 015                      | 015                |
| C12               | Lower Organ2 | o                 | o      | o      | o      | 017                      | 017                |
| C13               | Lower Organ3 | o                 | o      | o      | o      | 019                      | 019                |
| C14               | Lower Organ4 | o                 | o      | o      | o      | 016                      | 016                |
| C15               | Lower Organ5 | o                 | o      | o      | o      | 018                      | 018                |
| C16               | Lower Organ6 | o                 | o      | o      | o      | 020                      | 020                |
| D11               | Pipe Organ1  | o                 | o      | o      | o      | 021                      | 021                |
| D12               | Pipe Organ2  | o                 | o      | o      | o      | 023                      | 023                |
| D13               | Pipe Organ3  | o                 | o      | o      | o      | 025                      | 025                |
| D14               | Pipe Organ4  | o                 | o      | o      | o      | 022                      | 022                |
| D15               | Pipe Organ5  | o                 | o      | o      | o      | 024                      | 024                |
| D16               | Pipe Organ6  | o                 | o      | o      | o      | 026                      | 026                |
| D17               | Pipe Organ7  | o                 | o      | o      | o      | 034                      | 034                |
| D21               | Diapason 8'  | o                 | o      | o      | o      | -                        | -                  |
| D22               | FluteCeleste | o                 | o      | o      | -      | 021a                     | -                  |
| D23               | Gemshorn 8'  | o                 | o      | -      | -      | 034a                     | -                  |
| D24               | Trompet 8'   | o                 | o      | -      | -      | 034b                     | -                  |
| D25               | Hautbois 8'  | o                 | o      | -      | -      | 034c                     | -                  |
| D26               | Viola 8'     | o                 | o      | -      | -      | 034d                     | -                  |
| D27               | ViolaCeleste | o                 | o      | -      | -      | 034e                     | -                  |
| D28               | Bombarde16'  | o                 | o      | -      | -      | -                        | -                  |
| D31               | T.String 8'  | o                 | o      | -      | -      | 035a                     | -                  |
| D32               | VoxHumana 8' | o                 | o      | -      | -      | 035b                     | -                  |
| D33               | T.Tuba 8'    | o                 | o      | -      | -      | 035c                     | -                  |
| D34               | T.Trumpet 8' | o                 | o      | -      | -      | 035d                     | -                  |
| D35               | T.Sax 8'     | o                 | o      | -      | -      | 035e                     | -                  |
| D36               | T.Oboe 8'    | o                 | o      | -      | -      | 035f                     | -                  |
| D37               | T.Krumet 8'  | o                 | o      | -      | -      | 035g                     | -                  |
| D38               | Eng.Horn 8'  | o                 | o      | -      | -      | 035h                     | -                  |
| E11               | Theater Or.1 | o                 | o      | o      | o      | 027                      | 027                |
| E12               | Theater Or.2 | o                 | o      | o      | o      | 029                      | 029                |
| E13               | Theater Or.3 | o                 | o      | o      | o      | 031                      | 031                |
| E14               | Theater Or.4 | o                 | o      | o      | o      | 028                      | 028                |
| E15               | Theater Or.5 | o                 | o      | o      | o      | 030                      | 030                |
| E16               | Theater Or.6 | o                 | o      | o      | o      | 032                      | 032                |
| E17               | Theater Or.7 | o                 | o      | o      | -      | 035                      | 035                |
| F11               | Synth. Org.1 | o                 | o      | o      | o      | 036                      | 036                |
| F12               | Synth. Org.2 | o                 | o      | o      | o      | 037                      | 037                |
| F13               | Synth. Org.3 | o                 | o      | -      | -      | 036a                     | -                  |
| F14               | Synth. Org.4 | o                 | o      | -      | -      | 037a                     | -                  |
| F15               | Digi Church  | o                 | -      | -      | -      | -                        | -                  |
| F16               | Metalic Org  | o                 | -      | -      | -      | -                        | -                  |
| F21               | Pop. Organ1  | o                 | o      | o      | -      | 038                      | 038                |
| F22               | Pop. Organ2  | o                 | o      | o      | -      | 039                      | 039                |
| F23               | Pop. Organ3  | o                 | o      | o      | -      | 040                      | 040                |

| AT-R      |              | AT-90R/ |        |        |        | AT-90/AT-80 | AT-30     |
|-----------|--------------|---------|--------|--------|--------|-------------|-----------|
| Voice No. | Tone Name    | AT-80R  | AT-60R | AT-30R | AT-20R | Voice No.   | Voice No. |
| G11       | Strings1     | 0       | 0      | 0      | 0      | 041         | 041       |
| G12       | Strings2     | 0       | 0      | 0      | 0      | 042         | 042       |
| G13       | Strings3     | 0       | 0      | -      | -      | 041a        | -         |
| G14       | Strings4     | 0       | 0      | -      | -      | 042a        | -         |
| G15       | Strings5     | 0       | 0      | -      | -      | 041b        | -         |
| G16       | Strings6     | 0       | 0      | -      | -      | 041c        | -         |
| G17       | Strings7     | 0       | 0      | -      | -      | 041d        | -         |
| G18       | Strings8     | 0       | 0      | -      | -      | -           | -         |
| H11       | Slow Str.1   | 0       | 0      | 0      | 0      | 043         | 043       |
| H12       | Slow Str.2   | 0       | 0      | 0      | -      | 044         | 044       |
| H13       | Slow Str.3   | 0       | 0      | -      | -      | -           | -         |
| H21       | Synth. Str.1 | 0       | 0      | 0      | 0      | 045         | 045       |
| H22       | Synth. Str.2 | 0       | 0      | 0      | 0      | 046         | 046       |
| H23       | Synth. Str.3 | 0       | 0      | 0      | -      | 054         | 054       |
| H31       | Synth. Pad1  | 0       | 0      | 0      | 0      | 047         | 047       |
| H32       | Synth. Pad2  | 0       | 0      | 0      | 0      | 048         | 048       |
| I11       | Violin       | 0       | 0      | 0      | 0      | 093         | 093       |
| I12       | Viola        | 0       | 0      | 0      | 0      | 103         | 103       |
| I13       | Cello        | 0       | 0      | 0      | 0      | 094         | 094       |
| I14       | Pizzicato    | 0       | 0      | 0      | 0      | 056         | 056       |
| J11       | Jazz Scat    | 0       | 0      | 0      | 0      | -           | -         |
| J12       | Pop Voice    | 0       | 0      | 0      | 0      | 050         | 050       |
| J13       | Jazz Doo     | 0       | 0      | 0      | 0      | -           | -         |
| J14       | Jazz Doot    | 0       | 0      | 0      | 0      | -           | -         |
| J15       | Jazz Dat     | 0       | 0      | 0      | 0      | -           | -         |
| J16       | Jazz Bap     | 0       | 0      | 0      | 0      | -           | -         |
| J17       | JazzDowfall  | 0       | 0      | 0      | 0      | -           | -         |
| J18       | Soprano      | 0       | -      | -      | -      | -           | -         |
| J19       | Tenor        | 0       | -      | -      | -      | -           | -         |
| J21       | Choir        | 0       | 0      | 0      | 0      | 049         | 049       |
| J22       | Gregorian    | 0       | 0      | 0      | -      | -           | -         |
| J23       | Classical    | 0       | 0      | -      | -      | -           | -         |
| J24       | Boys Choir   | 0       | 0      | -      | -      | -           | -         |
| J25       | Female 1     | 0       | -      | -      | -      | -           | -         |
| J26       | Female 2     | 0       | -      | -      | -      | -           | -         |
| J27       | Gospel       | 0       | -      | -      | -      | -           | -         |
| J31       | Synth. Choir | 0       | 0      | 0      | -      | 051         | 051       |
| J32       | Synth. Voice | 0       | 0      | 0      | -      | 052         | 052       |
| J33       | Space Voice  | 0       | 0      | 0      | -      | 053         | 053       |
| J41       | Vocal Menu   | 0       | 0      | -      | -      | -           | -         |
| K11       | Grand Piano  | 0       | 0      | 0      | 0      | -           | -         |
| K12       | Piano1       | 0       | 0      | 0      | -      | 057         | 057       |
| K13       | Piano2       | 0       | 0      | 0      | -      | 080         | 080       |
| K14       | Piano3       | 0       | 0      | 0      | -      | 057a        | -         |
| K21       | Honky-tonk   | 0       | 0      | 0      | 0      | 058         | 058       |
| K22       | Honky-tonk2  | 0       | 0      | 0      | -      | -           | -         |
| K31       | E.Piano1     | 0       | 0      | 0      | 0      | 059         | 059       |
| K32       | E.Piano2     | 0       | 0      | 0      | 0      | 060         | 060       |
| K33       | E.Piano3     | 0       | 0      | 0      | -      | 059a        | -         |
| K34       | E.Piano4     | 0       | 0      | 0      | -      | -           | -         |
| K41       | Harpsichord  | 0       | 0      | 0      | 0      | 067         | 067       |
| K42       | Clavi.       | 0       | 0      | 0      | 0      | 081         | 081       |
| L11       | Accordion    | 0       | 0      | 0      | 0      | 073         | 073       |
| L12       | Bandoneon    | 0       | 0      | 0      | -      | 086         | 086       |
| L21       | Harmonica    | 0       | 0      | 0      | 0      | 074         | 074       |
| M11       | Nylon-str.Gt | 0       | 0      | 0      | 0      | 061         | 061       |
| M12       | Nylon Gt.2   | 0       | 0      | 0      | -      | 061a        | -         |
| M21       | Steel-str.Gt | 0       | 0      | 0      | 0      | 062         | 062       |
| M22       | 12str Guitar | 0       | -      | -      | -      | -           | -         |
| M31       | Jazz Guitar  | 0       | 0      | 0      | 0      | 063         | 063       |
| M32       | Clean Guitar | 0       | 0      | 0      | -      | 063a        | -         |
| M33       | JC E. Guitar | 0       | 0      | 0      | -      | 063b        | -         |

| AT-R      |               | AT-90R/ |        |        |        | AT-90/AT-80 | AT-30     |
|-----------|---------------|---------|--------|--------|--------|-------------|-----------|
| Voice No. | Tone Name     | AT-80R  | AT-60R | AT-30R | AT-20R | Voice No.   | Voice No. |
| M41       | Overdrive Gt  | 0       | 0      | 0      | 0      | 064         | 064       |
| M42       | OverdriveGt2  | 0       | -      | -      | -      | -           | -         |
| M43       | Power Guitar  | 0       | -      | -      | -      | -           | -         |
| M44       | Rock Rhythm   | 0       | -      | -      | -      | -           | -         |
| N11       | Hawaiian Gt.  | 0       | 0      | 0      | 0      | 087         | 087       |
| N12       | Banjo         | 0       | 0      | 0      | 0      | 072         | 072       |
| N13       | Mandolin      | 0       | 0      | 0      | -      | 071         | 071       |
| N14       | Koto          | 0       | 0      | 0      | -      | 068a        | -         |
| N15       | Taisho Koto   | 0       | 0      | 0      | -      | 068b        | -         |
| N16       | Shamisen      | 0       | 0      | 0      | -      | -           | -         |
| N21       | Harp          | 0       | 0      | 0      | 0      | 068         | 068       |
| N22       | Celtic Harp   | 0       | -      | -      | -      | -           | -         |
| N23       | Nylon Harp    | 0       | -      | -      | -      | -           | -         |
| N24       | Harpvox       | 0       | -      | -      | -      | -           | -         |
| N31       | Sitar         | 0       | 0      | 0      | 0      | 091         | 091       |
| N41       | Organ Harp    | 0       | 0      | 0      | -      | 088         | 088       |
| O11       | Vibraphone    | 0       | 0      | 0      | 0      | 069         | 069       |
| O12       | Glockenspiel  | 0       | 0      | 0      | 0      | 083         | 083       |
| O13       | Celesta       | 0       | 0      | 0      | 0      | 082         | 082       |
| O14       | Music Box     | 0       | -      | -      | -      | -           | -         |
| O21       | Marimba       | 0       | 0      | 0      | 0      | 070         | 070       |
| O22       | Xylophone     | 0       | 0      | 0      | 0      | 084         | 084       |
| O23       | Barafon       | 0       | -      | -      | -      | -           | -         |
| O31       | Tubular-bell  | 0       | 0      | 0      | 0      | 085         | 085       |
| O41       | Steel Drums   | 0       | 0      | 0      | 0      | 092         | 092       |
| O42       | Kalimba       | 0       | 0      | -      | -      | 091a        | -         |
| O51       | Organ Bell    | 0       | 0      | -      | -      | 085a        | -         |
| O52       | Vibra Bells   | 0       | 0      | -      | -      | -           | -         |
| O53       | Digi Bells    | 0       | -      | -      | -      | -           | -         |
| P11       | Tp. Section   | 0       | 0      | 0      | 0      | 065         | 065       |
| P12       | Brass 1       | 0       | -      | -      | -      | -           | -         |
| P13       | Brass 2       | 0       | -      | -      | -      | -           | -         |
| P14       | Brass 3       | 0       | -      | -      | -      | -           | -         |
| P21       | Fr.Horn Sect  | 0       | 0      | 0      | 0      | 089         | 089       |
| P22       | Fr.HornSect2  | 0       | 0      | -      | -      | 089a        | -         |
| P23       | Fr.HornSect3  | 0       | -      | -      | -      | -           | -         |
| P24       | Fr.HornSect4  | 0       | -      | -      | -      | -           | -         |
| P25       | Orch.Brs Ens  | 0       | -      | -      | -      | -           | -         |
| P26       | Muted Fr.Horn | 0       | -      | -      | -      | -           | -         |
| P31       | Sax.Section   | 0       | 0      | 0      | 0      | 066         | 066       |
| P32       | Sax.Section2  | 0       | 0      | -      | -      | 066a        | -         |
| P41       | Synth. Brass  | 0       | 0      | 0      | 0      | 090         | 090       |
| Q11       | Trumpet       | 0       | 0      | 0      | 0      | 095         | 095       |
| Q12       | Trumpet2      | 0       | 0      | -      | -      | 095a        | -         |
| Q21       | Mute Trumpet  | 0       | 0      | 0      | 0      | 096         | 096       |
| Q22       | MuteTrumpet2  | 0       | 0      | -      | -      | 096a        | -         |
| Q23       | Cup Mute Tp   | 0       | -      | -      | -      | -           | -         |
| Q31       | Trombone      | 0       | 0      | 0      | 0      | 105         | 105       |
| Q32       | Trombone2     | 0       | 0      | -      | -      | 105a        | -         |
| Q41       | Flugel Horn   | 0       | 0      | 0      | 0      | 104         | 104       |
| Q42       | F.Horn Solo1  | 0       | 0      | -      | -      | -           | -         |
| Q43       | F.Horn Solo2  | 0       | -      | -      | -      | -           | -         |
| Q51       | Soprano Sax   | 0       | 0      | 0      | 0      | 106         | 106       |
| Q52       | Soprano Sax2  | 0       | 0      | -      | -      | 106a        | -         |
| Q61       | Alto Sax      | 0       | 0      | 0      | 0      | 097         | 097       |
| Q62       | Alto Sax2     | 0       | 0      | -      | -      | 097a        | -         |
| Q63       | Blow Sax      | 0       | -      | -      | -      | -           | -         |
| Q71       | Tenor Sax     | 0       | 0      | 0      | 0      | 098         | 098       |
| Q72       | Tenor Sax2    | 0       | 0      | -      | -      | 098a        | -         |
| R11       | Flute         | 0       | 0      | 0      | 0      | 099         | 099       |
| R12       | Flute2        | 0       | 0      | -      | -      | 099a        | -         |
| R13       | Flute3        | 0       | 0      | -      | -      | -           | -         |
| R14       | Tin Whistle   | 0       | -      | -      | -      | -           | -         |



| AT-R<br>Voice No. | Tone Name     | AT-90R/ |        |        |        | AT-90/AT-80 |           | AT-30 |
|-------------------|---------------|---------|--------|--------|--------|-------------|-----------|-------|
|                   |               | AT-80R  | AT-60R | AT-30R | AT-20R | Voice No.   | Voice No. |       |
| R21               | Synth. Flute  | 0       | 0      | 0      | -      | 055         | 055       |       |
| R22               | Pan Flute     | 0       | 0      | 0      | 0      | 100         | 100       |       |
| R31               | Oboe          | 0       | 0      | 0      | 0      | 101         | 101       |       |
| R32               | Bassoon       | 0       | 0      | 0      | 0      | 107         | 107       |       |
| R33               | English Horn  | 0       | -      | -      | -      | -           | -         |       |
| R34               | Wood Winds    | 0       | -      | -      | -      | -           | -         |       |
| R41               | Clarinet      | 0       | 0      | 0      | 0      | 102         | 102       |       |
| R42               | Clarinet2     | 0       | 0      | -      | -      | 102a        | -         |       |
| R43               | Clarinet3     | 0       | 0      | -      | -      | 102b        | -         |       |
| R44               | Clarinet4     | 0       | 0      | -      | -      | 102c        | -         |       |
| R45               | Bs Clarinet   | 0       | 0      | -      | -      | -           | -         |       |
| R51               | Shakuhachi    | 0       | 0      | 0      | 0      | 108         | 108       |       |
| R52               | HumanWhistle  | 0       | 0      | 0      | -      | 109         | 109       |       |
| R61               | Bagpipe       | 0       | -      | -      | -      | -           | -         |       |
| R62               | Uilleann Pipe | 0       | -      | -      | -      | -           | -         |       |
| S11               | Synth. Lead1  | 0       | 0      | 0      | 0      | 110         | 110       |       |
| S12               | Synth. Lead2  | 0       | 0      | 0      | 0      | 111         | 111       |       |
| S13               | Synth. Lead3  | 0       | 0      | 0      | -      | 112         | 112       |       |
| S14               | Synth. Lead4  | 0       | 0      | 0      | -      | 113         | 113       |       |
| S15               | Synth. Lead5  | 0       | 0      | 0      | -      | 114         | 114       |       |
| S16               | CC Solo       | 0       | -      | -      | -      | -           | -         |       |
| T11               | Organ Bass1   | 0       | 0      | 0      | 0      | 115         | 115       |       |
| T12               | Organ Bass2   | 0       | 0      | 0      | 0      | 116         | 116       |       |
| T21               | Pipe Org. Bs  | 0       | 0      | 0      | 0      | 117         | 117       |       |
| T22               | Theater Bass  | 0       | 0      | -      | -      | 117a        | -         |       |
| T23               | Bombarde      | 0       | 0      | -      | -      | -           | -         |       |
| T31               | String Bass   | 0       | 0      | 0      | 0      | 118         | 118       |       |
| T32               | Bass+Cymbal   | 0       | 0      | 0      | 0      | 126         | 126       |       |
| T33               | String Bass2  | 0       | 0      | -      | -      | 118a        | -         |       |
| T41               | Contrabass1   | 0       | 0      | 0      | 0      | 121         | 121       |       |
| T42               | Contrabass2   | 0       | 0      | 0      | -      | 122         | 122       |       |
| T51               | E.Bass1       | 0       | 0      | 0      | 0      | 119         | 119       |       |
| T52               | E.Bass2       | 0       | 0      | 0      | 0      | 120         | 120       |       |
| T53               | E.Bass3       | 0       | 0      | -      | -      | 119a        | -         |       |
| T54               | E.Bass4       | 0       | 0      | -      | -      | 120a        | -         |       |
| T61               | Tuba          | 0       | 0      | 0      | 0      | 123         | 123       |       |
| T62               | Tuba2         | 0       | 0      | -      | -      | 123a        | -         |       |
| T71               | Synth. Bass1  | 0       | 0      | 0      | 0      | 124         | 124       |       |
| T72               | Synth. Bass2  | 0       | 0      | 0      | -      | 125         | 125       |       |
| T81               | Voice Thum    | 0       | 0      | 0      | 0      | -           | -         |       |
| U11               | Org. Attack1  | 0       | 0      | 0      | -      | 075         | 075       |       |
| U12               | Org. Attack2  | 0       | 0      | 0      | -      | 076         | 076       |       |
| U13               | Org. Attack3  | 0       | 0      | 0      | -      | 077         | 077       |       |
| U14               | Org. Attack4  | 0       | 0      | 0      | -      | 078         | 078       |       |
| U15               | Org. Click    | 0       | 0      | 0      | -      | 079         | 079       |       |
| V11               | Timpani       | 0       | 0      | 0      | -      | 127a        | -         |       |
| V12               | Timpani2      | 0       | 0      | -      | -      | -           | -         |       |
| V21               | Ride Cymbal   | 0       | 0      | -      | -      | 126a        | -         |       |
| V22               | Crash Cymbal  | 0       | 0      | -      | -      | 126b        | -         |       |
| V23               | Tambourine    | 0       | 0      | -      | -      | 126c        | -         |       |
| V24               | Woodblock     | 0       | 0      | -      | -      | 126d        | -         |       |
| V25               | Jingle Bell   | 0       | 0      | -      | -      | 126e        | -         |       |
| V26               | Snare Drum    | 0       | 0      | -      | -      | 126f        | -         |       |
| V27               | Bass Drum     | 0       | 0      | -      | -      | 126g        | -         |       |
| V28               | Church Bell   | 0       | -      | -      | -      | -           | -         |       |
| V31               | Perc. Set1    | 0       | 0      | 0      | -      | 127         | 127       |       |
| V32               | Perc. Set2    | 0       | 0      | 0      | -      | 128         | 128       |       |
| V33               | Perc. Set3    | 0       | 0      | -      | -      | 128a        | -         |       |
| V34               | Orch.HitMenu  | 0       | 0      | -      | -      | -           | -         |       |
| V35               | DanceHitMenu  | 0       | -      | -      | -      | -           | -         |       |

## Rhythm List (AT-90R/80R/60R/30R/20R)

|               | 90R | 80R | 60R | 30R | 20R |              | 90R | 80R | 60R | 30R | 20R |
|---------------|-----|-----|-----|-----|-----|--------------|-----|-----|-----|-----|-----|
| Fast BigBand  | 0   | 0   | 0   | 0   | -   | G.Pop        | 0   | 0   | 0   | 0   | 0   |
| New Big Band  | 0   | 0   | 0   | -   | -   | G.Fast Pop   | 0   | 0   | 0   | 0   | -   |
| BigBandSwing  | 0   | 0   | 0   | 0   | 0   | P.Slow       | 0   | 0   | 0   | 0   | 0   |
| BigBndBallad  | 0   | 0   | 0   | 0   | -   | P.Jazz       | 0   | 0   | 0   | 0   | -   |
| Jazz Band     | 0   | 0   | 0   | -   | -   | G.Slow       | 0   | 0   | -   | -   | -   |
| Big Band      | 0   | 0   | 0   | 0   | 0   | G.Shuffle    | 0   | 0   | 0   | -   | -   |
| Big Band 2    | 0   | 0   | 0   | -   | -   | P.Night      | 0   | 0   | 0   | 0   | 0   |
| Boogie        | 0   | 0   | -   | -   | -   | P.Pop        | 0   | 0   | -   | -   | -   |
| Blues         | 0   | 0   | -   | -   | -   | P.Concerto   | 0   | 0   | -   | -   | -   |
| A Cappella    | 0   | 0   | 0   | 0   | 0   | Hawaiian     | 0   | 0   | 0   | 0   | 0   |
| Combo         | 0   | 0   | 0   | 0   | 0   | French Waltz | 0   | 0   | 0   | -   | -   |
| Club Swing    | 0   | 0   | -   | -   | -   | D Marsch 6/8 | 0   | 0   | 0   | -   | -   |
| Medium Swing  | 0   | 0   | 0   | -   | -   | Scotland     | 0   | 0   | 0   | -   | -   |
| Slow Swing    | 0   | 0   | 0   | -   | -   | Ireland      | 0   | 0   | 0   | -   | -   |
| Vocal Swing   | 0   | 0   | -   | -   | -   | Reggae       | 0   | 0   | 0   | 0   | -   |
| Swing         | 0   | 0   | 0   | -   | -   | Habanera     | 0   | 0   | -   | -   | -   |
| Shuffle       | 0   | 0   | 0   | -   | -   | Sevilla      | 0   | 0   | -   | -   | -   |
| CountryRoads  | 0   | 0   | 0   | -   | -   | Bossa Nova   | 0   | 0   | 0   | 0   | 0   |
| CountryPiano  | 0   | 0   | 0   | 0   | -   | Bossa Nova2  | 0   | 0   | 0   | -   | -   |
| CtrySerenade  | 0   | 0   | -   | -   | -   | FastBosaNova | 0   | 0   | 0   | -   | -   |
| Western       | 0   | -   | -   | -   | -   | Slow Bossa   | 0   | 0   | 0   | 0   | 0   |
| CountrySwing  | 0   | 0   | 0   | -   | -   | NewBossaNova | 0   | 0   | -   | -   | -   |
| Hoedown       | 0   | 0   | 0   | 0   | 0   | Chacha       | 0   | 0   | 0   | 0   | -   |
| Twostep       | 0   | 0   | 0   | -   | -   | Chacha 2     | 0   | 0   | -   | -   | -   |
| CountryWaltz  | 0   | 0   | 0   | 0   | 0   | Salsa        | 0   | 0   | 0   | 0   | 0   |
| Easy Country  | 0   | 0   | 0   | 0   | 0   | Samba        | 0   | 0   | -   | -   | -   |
| Cajun         | 0   | 0   | -   | -   | -   | Rhumba       | 0   | 0   | 0   | 0   | 0   |
| Beach Sound   | 0   | 0   | 0   | -   | -   | Rhumba 2     | 0   | -   | -   | -   | -   |
| Rock'n'Roll   | 0   | 0   | 0   | -   | -   | Beguine      | 0   | 0   | 0   | 0   | -   |
| Twist         | 0   | 0   | 0   | 0   | 0   | Mambo        | 0   | 0   | 0   | 0   | 0   |
| 50'sBallad    | 0   | -   | -   | -   | -   | Tango 1      | 0   | 0   | 0   | 0   | 0   |
| Slow Dance    | 0   | 0   | 0   | 0   | 0   | Tango 2      | 0   | 0   | 0   | -   | -   |
| Dreamin'      | 0   | 0   | 0   | 0   | -   | Latin Fusion | 0   | 0   | -   | -   | -   |
| 50's Pop 1    | 0   | 0   | 0   | 0   | 0   | Samba Rio    | 0   | 0   | 0   | 0   | 0   |
| 50's Pop 2    | 0   | 0   | -   | -   | -   | Screen 1     | 0   | 0   | 0   | 0   | -   |
| Love Romance  | 0   | 0   | 0   | 0   | 0   | Screen 2     | 0   | 0   | 0   | -   | -   |
| Torch Song    | 0   | 0   | 0   | 0   | 0   | Music Hall   | 0   | 0   | 0   | -   | -   |
| Torch Song 2  | 0   | 0   | -   | -   | -   | Broadway     | 0   | 0   | 0   | 0   | -   |
| Love Songs    | 0   | 0   | 0   | 0   | 0   | ChooChooSwg  | 0   | 0   | 0   | -   | -   |
| MediumBallad  | 0   | 0   | 0   | -   | -   | Bubbles      | 0   | 0   | -   | -   | -   |
| Pop Ballad    | 0   | 0   | -   | -   | -   | Balloon Trip | 0   | 0   | -   | -   | -   |
| Ballad        | 0   | 0   | 0   | 0   | -   | Raindrops    | 0   | 0   | 0   | 0   | 0   |
| Classic       | 0   | 0   | 0   | -   | -   | Festival     | 0   | 0   | 0   | 0   | -   |
| Dixieland     | 0   | 0   | 0   | 0   | 0   | Little Steps | 0   | 0   | -   | -   | -   |
| Polka         | 0   | 0   | 0   | 0   | -   | WesternMovie | 0   | -   | -   | -   | -   |
| Foxtrot       | 0   | 0   | 0   | -   | -   |              |     |     |     |     |     |
| Charleston    | 0   | 0   | 0   | -   | -   |              |     |     |     |     |     |
| PianoBoogie 1 | 0   | 0   | 0   | -   | -   |              |     |     |     |     |     |
| PianoBoogie2  | 0   | -   | -   | -   | -   |              |     |     |     |     |     |
| Rag Time      | 0   | 0   | -   | -   | -   |              |     |     |     |     |     |

|              | 90R | 80R | 60R | 30R | 20R |
|--------------|-----|-----|-----|-----|-----|
| 8Beat Pop    | 0   | 0   | 0   | -   | -   |
| Swing Pop    | 0   | 0   | 0   | 0   | 0   |
| PopularPiano | 0   | 0   | 0   | 0   | -   |
| Acoustic Pop | 0   | 0   | 0   | -   | -   |
| Pop'n Roll   | 0   | 0   | -   | -   | -   |
| Easy Listen1 | 0   | 0   | 0   | 0   | 0   |
| Easy Listen2 | 0   | 0   | 0   | 0   | 0   |
| Easy Listen3 | 0   | 0   | -   | -   | -   |
| Easy Listen4 | 0   | 0   | -   | -   | -   |
| Easy Listen5 | 0   | -   | -   | -   | -   |
| Rollin'      | 0   | 0   | 0   | -   | -   |
| 16BeatShuffl | 0   | 0   | -   | -   | -   |
| Motown       | 0   | 0   | 0   | 0   | -   |
| ShufflePop 1 | 0   | 0   | 0   | -   | -   |
| ShufflePop 2 | 0   | 0   | 0   | -   | -   |
| Rock'n'Shffl | 0   | 0   | -   | -   | -   |
| Light Fusion | 0   | 0   | -   | -   | -   |
| Rock'n Pop   | 0   | 0   | 0   | -   | -   |
| Gospel Piano | 0   | -   | -   | -   | -   |
| Gospel Pop   | 0   | 0   | 0   | 0   | -   |
| GospelBallad | 0   | 0   | -   | -   | -   |
| Gospel 1     | 0   | 0   | 0   | -   | -   |
| Gospel 2     | 0   | 0   | -   | -   | -   |
| Anthem       | 0   | 0   | 0   | 0   | -   |
| Revival      | 0   | 0   | 0   | -   | -   |
| Chapel       | 0   | -   | -   | -   | -   |
| Last Dance   | 0   | 0   | 0   | 0   | -   |
| Jazz Waltz   | 0   | 0   | 0   | -   | -   |
| StringsWaltz | 0   | 0   | 0   | -   | -   |
| Slow Waltz   | 0   | 0   | 0   | 0   | 0   |
| Waltz        | 0   | 0   | -   | -   | -   |
| Musette      | 0   | 0   | 0   | 0   | -   |
| Vienna Waltz | 0   | 0   | -   | -   | -   |
| March 4/4    | 0   | 0   | 0   | 0   | 0   |
| March 6/8    | 0   | 0   | 0   | 0   | 0   |
| March 2/4    | 0   | 0   | -   | -   | -   |
| Simple March | 0   | 0   | -   | -   | -   |
| Cute Pop     | 0   | 0   | 0   | -   | -   |
| R&B          | 0   | 0   | -   | -   | -   |
| Slow Rock    | 0   | -   | -   | -   | -   |
| Rock'n'Roll2 | 0   | 0   | -   | -   | -   |
| 60'sBallad   | 0   | 0   | 0   | -   | -   |
| Crystal      | 0   | 0   | -   | -   | -   |
| Bossa Nova 3 | 0   | 0   | 0   | -   | -   |
| Bossa Nova 4 | 0   | 0   | 0   | -   | -   |
| Cinema       | 0   | 0   | -   | -   | -   |
| Entertaining | 0   | 0   | -   | -   | -   |
| 70's Disco   | 0   | -   | -   | -   | -   |
| 16Beat Pop 1 | 0   | 0   | 0   | -   | -   |
| 16Beat Pop 2 | 0   | 0   | 0   | -   | -   |
| AcousticRock | 0   | 0   | -   | -   | -   |
| Rock 1       | 0   | -   | -   | -   | -   |
| Rock 2       | 0   | -   | -   | -   | -   |

# Rhythm List

左ページ (P.8、10) は AT-90/80/30、右ページ (P.9、11) は AT-90R/80R/60R/30R/20R のリズム一覧表です。

The lists on left pages (p.8, 10) are AT-90/80/30 Rhythm List.

The lists on right pages (p.9, 11) are AT-90R/80R/60R/30R/20R Rhythm List.

| AT-90        | AT-80        | AT-80 for Japan | AT-30        |
|--------------|--------------|-----------------|--------------|
| Jazz Band    | -            | Jazz Band       | Jazz Band    |
| Big Band     | -            | -               | Big Band     |
| -            | Big Band     | Big Band        | -            |
| -            | Blues        | -               | -            |
| BigBndBallad | -            | -               | BigBndBallad |
| -            | BigBndBallad | BigBndBallad    | -            |
| Boogie       | -            | Boogie          | -            |
| Standard     | Standard     | Standard        | -            |
| -            | Vocal Swing  | -               | -            |
| Combo        | Combo        | Combo           | Combo        |
| Medium Swing | -            | Medium Swing    | -            |
| Shuffle      | -            | -               | -            |
| Swing        | Swing        | Swing           | Swing        |
| -            | Club Piano   | Club Piano      | -            |
| Cntry Ballad | Cntry Ballad | -               | -            |
| CountrySwing | CountrySwing | -               | -            |
| -            | -            | Two Step        | Two Step     |
| Bluegrass    | Bluegrass    | Bluegrass       | -            |
| -            | -            | -               | Bluegrass    |
| CountryWaltz | CntryWltz    | -               | CountryWaltz |
| -            | Easy Country | -               | -            |
| Hoe Down     | Hoe Down     | -               | -            |
| New Country  | -            | New Country     | -            |
| -            | -            | Western         | -            |
| Two Step     | Two Step     | -               | -            |
| -            | -            | Country Rock    | -            |
| -            | -            | DancePop 1      | -            |
| -            | -            | DancePop 2      | -            |
| -            | -            | 70's Disco      | -            |
| -            | -            | Light Fusion    | -            |
| -            | -            | Rock 1          | -            |
| -            | -            | Rock 2          | -            |
| -            | 50's Ballad  | -               | -            |
| Slow Dance   | Slow Dance   | 50'sBallad 1    | -            |
| 50's         | 50's         | -               | -            |
| -            | -            | -               | Twist        |
| Rock'n'Roll1 | Rock'n'Roll  | Rock'n'Roll1    | Rock'n'Roll1 |
| Rock'n'Roll2 | -            | Rock'n'Roll2    | Rock'n'Roll2 |
| -            | -            | R&B             | -            |
| -            | -            | AcousticRock    | -            |
| Love Songs   | Love Songs   | -               | Love Songs   |
| Ballad       | Ballad       | Ballad 1        | Ballad       |
| -            | -            | 50'sBallad 2    | -            |
| -            | -            | 16BeatBallad    | -            |
| Classic      | Classic      | -               | Classic      |
| -            | Torch Song   | -               | -            |
| -            | Piano Boogie | -               | -            |
| -            | -            | Festival        | -            |

※ Disk と書かれているのは、添付のミュージック・スタイル・ディスクのリズム番号です。  
 ※ World と書かれているのは、添付のワールド・スタイル・セットアップ・ディスクのリズム番号です。

\* Disk-\*\*: Rhythm Number of Music Style Disk  
 \* World-\*\*: Rhythm Number of World Style Setup Disk

| AT-90R       | AT-80R       | AT-60R       | AT-30R       | AT-20R       |
|--------------|--------------|--------------|--------------|--------------|
| Jazz Band    | Jazz Band    | Jazz Band    | Disk-03      | Disk-03      |
| Big Band     | Big Band     | Big Band     | Big Band     | Big Band     |
| Big Band2    | Big Band2    | Big Band2    | -            | -            |
| Blues        | Blues        | -            | -            | -            |
| Disk1-01     | Disk1-01     | Disk1-01     | Disk-01      | Disk-01      |
| BigBndBallad | BigBndBallad | BigBndBallad | BigBndBallad | -            |
| Boogie       | Boogie       | Disk1-05     | -            | -            |
| Disk1-02     | Disk1-02     | Disk1-02     | -            | -            |
| Vocal Swing  | Vocal Swing  | -            | -            | -            |
| Combo        | Combo        | Combo        | Combo        | Combo        |
| Disk1-07     | Disk1-07     | Disk1-07     | Disk-08      | Disk-08      |
| Shuffle      | Shuffle      | Shuffle      | -            | -            |
| Swing        | Swing        | Swing        | Disk-07      | Disk-07      |
| Club Swing   | Club Swing   | -            | -            | -            |
| Disk1-13     | Disk1-13     | Disk1-13     | Disk-14      | Disk-14      |
| CountrySwing | CountrySwing | CountrySwing | Disk-15      | Disk-15      |
| Disk1-15     | Disk1-15     | Disk1-15     | Disk-16      | Disk-16      |
| Disk1-10     | Disk1-10     | Disk1-10     | Disk-10      | Disk-10      |
| Disk1-11     | Disk1-11     | Disk1-11     | Disk-11      | Disk-11      |
| CountryWaltz | CountryWaltz | CountryWaltz | CountryWaltz | CountryWaltz |
| Easy Country | Easy Country | Easy Country | Easy Country | Easy Country |
| Hoedown      | Hoedown      | Hoedown      | Hoedown      | Hoedown      |
| Cajun        | Cajun        | Disk2-01     | Disk-12      | Disk-12      |
| Western      | Disk2-02     | Disk2-02     | -            | -            |
| Twostep      | Twostep      | -            | -            | -            |
| Disk2-02     | Disk2-03     | -            | -            | -            |
| Disk2-32     | Disk2-29     | Disk2-14     | -            | -            |
| Disk2-33     | Disk2-30     | Disk2-15     | Disk-62      | Disk-62      |
| Disk2-31     | Disk2-28     | -            | -            | -            |
| Light Fusion | Light Fusion | -            | -            | -            |
| Rock 1       | Disk2-24     | Disk2-12     | -            | -            |
| Rock 2       | Disk2-25     | Disk2-13     | -            | -            |
| 50'sBallad   | Disk2-05     | -            | -            | -            |
| Slow Dance   | Slow Dance   | Slow Dance   | Slow Dance   | Slow Dance   |
| 50's Pop 1   | 50's Pop 1   | 50's Pop 1   | 50's Pop 1   | 50's Pop 1   |
| Twist        | Disk1-17     | Disk1-17     | Disk-18      | Disk-18      |
| Disk1-49     | Disk1-49     | Disk1-49     | Disk-57      | Disk-57      |
| Disk1-50     | Disk1-50     | Disk1-50     | Disk-58      | Disk-58      |
| R&B          | R&B          | -            | -            | -            |
| AcousticRock | AcousticRock | -            | -            | -            |
| Love Songs   | Love Songs   | Love Songs   | Love Songs   | Love Songs   |
| Ballad       | Ballad       | Ballad       | Ballad       | -            |
| Dreamin'     | Dreamin'     | Dreamin'     | Dreamin'     | -            |
| Easy Listen5 | Disk2-15     | Disk2-06     | Disk-42      | Disk-42      |
| Classic      | Classic      | Classic      | Disk-21      | Disk-21      |
| Torch Song   | Torch Song   | Torch Song   | Torch Song   | Torch Song   |
| PianoBoogie2 | Disk2-06     | -            | -            | -            |
| Festival     | Festival     | Festival     | -            | -            |

| AT-90        | AT-80        | AT-80 for Japan | AT-30        |
|--------------|--------------|-----------------|--------------|
| Foxtrot      | Foxtrot      | Foxtrot         | Foxtrot      |
| Dixieland    | -            | -               | Dixieland    |
| -            | Dixieland    | Dixieland       | -            |
| Charleston   | Charleston   | -               | -            |
| -            | -            | Reggae          | -            |
| -            | -            | Folk Dance      | -            |
| -            | -            | Kayou           | -            |
| Bossa Nova   | Bossa Nova   | -               | -            |
| -            | -            | Bossa Nova      | Bossa Nova   |
| Fast Bossa   | -            | FastBosaNova    | -            |
| Chacha       | Chacha       | Chacha          | Chacha       |
| Mambo        | -            | Mambo           | Mambo        |
| -            | -            | Salsa           | -            |
| Samba        | Samba        | Samba           | -            |
| Rhumba       | Rhumba       | Rhumba          | Rhumba       |
| -            | -            | -               | Samba        |
| Beguine      | -            | -               | Beguine      |
| -            | Beguine      | Beguine         | -            |
| Tango        | Tango        | -               | -            |
| -            | -            | Tango 1         | -            |
| -            | -            | Tango 2         | -            |
| -            | -            | -               | Tango        |
| -            | -            | Latin Fusion    | -            |
| -            | ChooChooSwg  | -               | -            |
| Music Hall   | Music Hall   | Music Hall      | -            |
| Broadway     | -            | -               | -            |
| Bubbles      | Bubbles      | -               | -            |
| -            | -            | Pop 1           | -            |
| -            | -            | Pop 2           | -            |
| -            | -            | Pop 3           | -            |
| -            | -            | Pop 4           | -            |
| -            | -            | Simple 8Beat    | -            |
| -            | -            | Contemporary    | -            |
| Easy Listen1 | Easy Listen1 | -               | -            |
| Easy Listen2 | Easy Listen2 | -               | Easy Listen1 |
| PopularPiano | PopularPiano | -               | PopularPiano |
| Pop          | -            | ShufflePop 1    | Pop          |
| -            | -            | ShufflePop 2    | -            |
| -            | -            | Rock'n Shffl    | -            |
| -            | -            | 16Bt Shuffle    | -            |
| -            | -            | -               | Easy Listen2 |
| Gospel       | Gospel       | Gospel 1        | -            |
| -            | -            | Gospel 2        | -            |
| Revival      | Revival      | New Gospel      | -            |
| Anthem       | Anthem       | Slow Gospel     | -            |
| GospelBallad | -            | GospelBallad    | -            |
| March 4/4    | March 4/4    | March 4/4       | March 4/4    |
| March 6/8    | March 6/8    | March 6/8       | March 6/8    |
| -            | German March | March 2/4       | -            |
| -            | -            | Simple March    | -            |
| Slow Waltz   | Slow Waltz   | Slow Waltz      | Slow Waltz   |
| Slow Waltz 2 | -            | -               | -            |
| Musette      | Musette      | Musette         | Musette      |
| Vienna Waltz | Vienna Waltz | Vienna Waltz    | Vienna Waltz |
| -            | Waltz        | Waltz           | -            |
| Hawaiian     | Hawaiian     | Hawaiian        | Hawaiian     |
| Polka        | Polka        | Polka           | Polka        |

| AT-90R       | AT-80R       | AT-60R       | AT-30R       | AT-20R       |
|--------------|--------------|--------------|--------------|--------------|
| Foxtrot      | Foxtrot      | Foxtrot      | Disk-24      | Disk-24      |
| Disk1-22     | Disk1-22     | Disk1-22     | Disk-23      | Disk-23      |
| Dixieland    | Dixieland    | Dixieland    | Dixieland    | Dixieland    |
| Charleston   | Charleston   | Charleston   | Disk-22      | Disk-22      |
| Disk2-5      | Disk2-7      | -            | -            | -            |
| Disk2-25     | Disk2-21     | -            | -            | -            |
| World-33     | World-33     | World-33     | World-33     | -            |
| Bossa Nova2  | Bossa Nova2  | Bossa Nova2  | Disk-31      | Disk-31      |
| Disk1-29     | Disk1-29     | Disk1-29     | Disk-33      | Disk-33      |
| FastBosaNova | FastBosaNova | FastBosaNova | Disk-32      | Disk-32      |
| Chacha       | Chacha       | Chacha       | Chacha       | -            |
| Disk1-32     | Disk1-32     | Disk1-32     | Disk-36      | Disk-36      |
| Salsa        | Salsa        | Salsa        | Salsa        | Salsa        |
| Samba Rio    | Samba Rio    | Samba Rio    | Samba Rio    | Samba Rio    |
| Rhumba       | Rhumba       | Rhumba       | Rhumba       | Rhumba       |
| Disk1-33     | Disk1-33     | Disk1-33     | Disk-37      | Disk-37      |
| Disk1-36     | Disk1-36     | Disk1-36     | Disk-39      | Disk-39      |
| Beguine      | Beguine      | Beguine      | Beguine      | -            |
| Disk1-34     | Disk1-34     | Disk1-34     | -            | -            |
| Tango 1      | Tango 1      | Tango 1      | Tango 1      | Tango 1      |
| Disk2-11     | Disk2-10     | -            | -            | -            |
| Disk1-35     | Disk1-35     | Disk1-35     | Disk-38      | Disk-38      |
| Latin Fusion | Latin Fusion | -            | -            | -            |
| ChooChooSwg  | ChooChooSwg  | ChooChooSwg  | -            | -            |
| Music Hall   | Music Hall   | Music Hall   | -            | -            |
| Broadway     | Broadway     | Broadway     | Broadway     | -            |
| Bubbles      | Bubbles      | -            | -            | -            |
| Disk2-13     | Disk2-11     | -            | -            | -            |
| Disk1-41     | Disk1-41     | Disk1-41     | Disk-45      | Disk-45      |
| Disk2-14     | Disk2-12     | -            | -            | -            |
| Disk2-15     | Disk2-13     | -            | -            | -            |
| Disk2-16     | Disk2-14     | -            | -            | -            |
| Disk1-52     | Disk1-52     | Disk1-52     | Disk-59      | Disk-59      |
| Easy Listen1 | Easy Listen1 | Easy Listen1 | Easy Listen1 | Easy Listen1 |
| Easy Listen2 | Easy Listen2 | Easy Listen2 | Easy Listen2 | Easy Listen2 |
| PopularPiano | PopularPiano | PopularPiano | PopularPiano | -            |
| ShufflePop 1 | ShufflePop 1 | ShufflePop 1 | Disk-46      | Disk-46      |
| ShufflePop 2 | ShufflePop 2 | ShufflePop 2 | -            | -            |
| Rock'n'Shffl | Rock'n'Shffl | -            | -            | -            |
| Disk2-21     | Disk2-17     | -            | -            | -            |
| Easy Listen3 | Easy Listen3 | Disk2-04     | Disk-40      | Disk-40      |
| Gospel 1     | Gospel 1     | Gospel 1     | -            | -            |
| Gospel 2     | Gospel 2     | Disk2-07     | Disk-47      | Disk-47      |
| Revival      | Revival      | Revival      | -            | -            |
| Anthem       | Anthem       | Anthem       | Anthem       | -            |
| GospelBallad | GospelBallad | Disk2-08     | Disk-48      | Disk-48      |
| March 4/4    | March 4/4    | March 4/4    | March 4/4    | March 4/4    |
| March 6/8    | March 6/8    | March 6/8    | March 6/8    | March 6/8    |
| March 2/4    | March 2/4    | Disk2-10     | Disk-54      | Disk-54      |
| Simple March | Simple March | -            | -            | -            |
| Slow Waltz   | Slow Waltz   | Slow Waltz   | Slow Waltz   | Slow Waltz   |
| Disk1-43     | Disk1-43     | Disk1-43     | Disk-52      | Disk-52      |
| Musette      | Musette      | Musette      | Musette      | -            |
| Vienna Waltz | Vienna Waltz | Disk2-09     | Disk-50      | Disk-50      |
| Waltz        | Waltz        | -            | -            | -            |
| Hawaiian     | Hawaiian     | Hawaiian     | Hawaiian     | Hawaiian     |
| Polka        | Polka        | Polka        | Polka        | -            |







This product complies with the requirements of European Directives EMC 89/336/EEC and LVD 73/23/EEC.

For EU Countries

## FEDERAL COMMUNICATIONS COMMISSION RADIO FREQUENCY INTERFERENCE STATEMENT

This equipment has been tested and found to comply with the limits for a Class B digital device, pursuant to Part 15 of the FCC Rules. These limits are designed to provide reasonable protection against harmful interference in a residential installation. This equipment generates, uses, and can radiate radio frequency energy and, if not installed and used in accordance with the instructions, may cause harmful interference to radio communications. However, there is no guarantee that interference will not occur in a particular installation. If this equipment does cause harmful interference to radio or television reception, which can be determined by turning the equipment off and on, the user is encouraged to try to correct the interference by one or more of the following measures:

- Reorient or relocate the receiving antenna.
- Increase the separation between the equipment and receiver.
- Connect the equipment into an outlet on a circuit different from that to which the receiver is connected.
- Consult the dealer or an experienced radio/TV technician for help.

Unauthorized changes or modification to this system can void the users authority to operate this equipment.  
This equipment requires shielded interface cables in order to meet FCC class B Limit.

For the USA

## NOTICE

This Class B digital apparatus meets all requirements of the Canadian Interference-Causing Equipment Regulations.

For Canada

## AVIS

Cet appareil numérique de la classe B respecte toutes les exigences du Règlement sur le matériel brouilleur du Canada.

 Roland®

---

71235912

UPC 71235912



10981