

# Roland

## CD-5

CD-ROM PLAYER

Owner's Manual

for S-550

## WARNING

To prevent fire or shock hazard, do not expose the unit to rain or moisture.

To avoid electrical shock, do not open the cabinet. Refer servicing to qualified personnel only.

### INFORMATION

This equipment generates and uses radio frequency energy and if not installed and used properly, that is, in strict accordance with the manufacturer's instructions, may cause interference to radio and television reception. It has been type tested and found to comply with the limits for a Class B computing device in accordance with the specifications in Subpart J of Part 15 of FCC Rules, which are designed to provide reasonable protection against such interference in a residential installation. However, there is no guarantee that interference will not occur in a particular installation. If this equipment does cause interference to radio or television reception, which can be determined by turning the equipment off and on, the user is encouraged to try to correct the interference by one or more of the following measures:

- Reorient the receiving antenna
- Relocate the equipment with respect to the receiver
- Move the equipment away from the receiver
- Plug the equipment into a different outlet so that equipment and receiver are on different branch circuits.

If necessary, the user should consult the dealer or an experienced radio/television technician for additional suggestions. The user may find the following booklet prepared by the Federal Communications Commission helpful:

"How to Identify and Resolve Radio-TV Interference Problems". This booklet is available from the U.S. Government Printing Office, Washington, DC 20402. Stock No. 004-000-00345-4.

The shielded interface cable recommended in this manual must be used with this equipment in order to comply with the limits for a computing device pursuant to subpart J of Part 15 of FCC Rules.

Connecting cable RCC-015H

### CAUTION

As the laser beam used in this CDU-6110-01/6111-01 is harmful to the eyes, do not attempt to disassemble the cabinet. Refer servicing to qualified personnel only.

The use of optical instruments with this product will increase eye hazard.

This unit uses CD-ROM discs with the following mark.



When you use this unit as a CD player, use compact discs with the following mark.



CLASS 1  
LASER PRODUCT  
LASER KLASSE 1

This CD-ROM drive is classified as a CLASS 1 LASER product. The CLASS 1 LASER PRODUCT label is located on the bottom.

## Zu Ihrer Sicherheit

### VORSICHT

Um Feuergefahr und die Gefahr eines elektrischen Schlages zu vermeiden, darf das Gerät weder Regen noch Feuchtigkeit ausgesetzt werden.

Um einen elektrischen Schlag zu vermeiden, darf das Gehäuse nicht geöffnet werden. Überlassen Sie Wartungsarbeiten stets nur einem Fachmann.

### ACHTUNG

Da der interne Laserstrahl in Ihre Augen eindringen und Verletzungen verursachen kann, darf das Gehäuse nicht selbst geöffnet werden. Überlassen Sie Wartungsarbeiten stets nur einem Fachmann.

Die Verwendung von Brillen, Kontaktlinsen usw. vergrößert die Gefahr

### Zur besonderen Beachtung

#### Zur Sicherheit

- Betreiben Sie das Gerät entweder an 100-120V Wechselspannung, 50/60Hz (USA-Version) oder 220-240V Wechselspannung, 50/60Hz (Europa-Version)
- Sollte ein fester Gegenstand oder Flüssigkeit in das Geräteinnere gelangen, trennen Sie das Gerät von der Wandsteckdose ab und lassen Sie es von einem Fachmann überprüfen, bevor Sie es weiter verwenden.
- Zum Abziehen des Kabels fassen Sie stets am Stecker und niemals am Kabel selbst an

#### Zur Aufstellung

- Stellen Sie das Gerät weder auf einer weichen Unterlage (z. B. Decke, Teppich) noch in der Nähe von Vorhängen, Tapeten usw. auf, da hierdurch die Ventilationsöffnungen blockiert werden können.

### Zur Reinigung

Verwenden Sie zur Reinigung des Gehäuses, des Bedienungspultes und der Bedienungselemente ein trockenes, weiches Tuch oder ein weiches, leicht mit mildem Haushaltsreiniger angefeuchtetes Tuch. Lösungsmittel wie Alkohol oder Benzin dürfen nicht verwendet werden, da diese die Gehäusesoberfläche angreifen.

### Bescheinigung des Herstellers

Hiermit wird bescheinigt, daß das CDU-6110-01/6111-01 in Übereinstimmung mit den Bestimmungen der Amtsblattverfügung Nr. 1046/1984 funktentstört ist.

Der Deutschen Bundespost wurde das Inverkehrbringen dieses Gerätes angezeigt und die Berechtigung zur Überprüfung der Serie auf Einhaltung der Bestimmungen eingeräumt.  
Roland Corporation

### Hinweis

Gemäß dem Amtsblatt des Bundesministers für das Post- und Fernmeldewesen Nr. 163/1984 wird der Betreiber darauf aufmerksam gemacht, daß die von ihm mit diesem Gerät zusammengestellte Anlage auch den technischen Bestimmungen dieses Amtsblattes genügen muß.

#### Hinweis

Dieses Gerät erfüllt bezüglich Störstrahlungsunterdrückung die EWG-Richtlinien 76/889 und 82/499.

Änderungen, die dem technischen Fortschritt dienen, bleiben vorbehalten

Copyright © 1988 by ROLAND CORPORATION

All rights reserved. No part of this publication may be reproduced in any form without the written permission of ROLAND CORPORATION.

## ■ INTRODUCTION

Thank you, and congratulations on your purchase of the Roland CD-5. Through connection with the S-550, or other equipment, the CD-5 allows you to select any sound you need from the enormous volumes of data you now have available.

● Included with the unit is a CD-ROM disc stocked with original sound data from Roland – an amount equivalent to 165 floppy disks. Everything contained in this library was painstakingly recorded, digitally, and is of the purest quality. In addition to all the common instruments, also included are Japanese instruments and a variety of ethnic and folk instruments that would otherwise be difficult to obtain.

● The CD-5 also doubles as an audio CD player. Sampling from CD has now reached a new level of convenience, thanks to its ability to insert cue points for sampling.

In order to make use of the CD-5, you will need to install the optionally available HD5-IF. If you have not yet acquired the HD5-IF, please purchase it at the dealer where you obtained the S-550 or CD-5.

When connecting the CD-5 to devices other than the S-550, refer to the manual supplied with that equipment.

## ■ CONTENTS

■ Important Notes .....	5
■ Front & Rear Panel Descriptions .....	6
■ Handling of discs and the caddy .....	7
<b>1 Setup .....</b>	<b>11</b>
■ Single CD-5 configuration .....	12
■ Configuration with CD-5 plus Hard Disk ..	18
■ when connecting multiple CD-5s or hard disks .....	26
<b>2 Loading sound data from the CD-5 .. 27</b>	
1. Loading sound data .....	28
2. Loading Patches .....	29
3. Tone loading .....	32
<b>3 Revisions over S-550 VER.1.0 .....</b>	<b>33</b>
<b>4 Use as a CD player .....</b>	<b>42</b>
<b>5 Sampling from the CD-5 .....</b>	<b>43</b>
<b>6 Backing up the System Disk .....</b>	<b>45</b>
■ Troubleshooting .....	46
1. SCSI Check .....	46
2. Error messages .....	48
■ MIDI Implementation Chart .....	49
■ Specifications .....	50

- The system disk provided with the CD-5 can be used to drive not only the CD-5, but hard disks as well.
- Similar to the S-550's utility disk, the system disk provided with the CD-5 is comprised of the System Program and Utility systems. (No sound data is contained here.) Among included utility systems are those system files needed for operation of the CD-5, as well as hard disks.

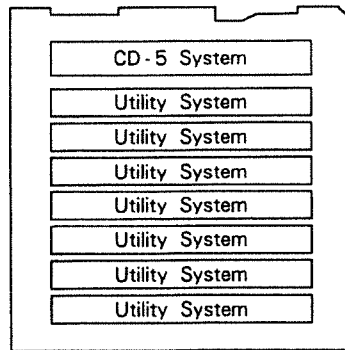

- The System Disk is not simply a combination of the S-550 system plus programs that function in operating the CD-5 and hard disks, but has been revised overall, with new functions being added in order to offer improved performance and ease of use. For details on differences compared with S-550 Ver. 1.0, see page 33.

Revised areas :	Extent of revision :
Convert function	Now supports conversion of S-550 data for use with S-50
Naming	Mouse can be used to input names
Mapping	The same values can be entered continuously
Split settings	Split settings allow viewing tone list
DC - Cut	A function that removes the DC contents from wave
Transfer of data to floppies	"FD" prefix added to menus and commands
Patch loading	Supports loading of not just patch parameters, but the tones used in them as well
Patch deletion	Now capable of deleting S-550 internal patches

- In all menus concerned with floppy and hard disk drive, and CD-5 operations, either "FD", "CD" or "HD" have been added as prefixes. "FD" stands for floppy disk, "CD" for the CD-5, and "HD" for hard disk. When there is no hard disk connected, all menus and commands with the "HD" prefix are inactive.

## ■ IMPORTANT NOTES

- The appropriate power supply for this unit is shown on its name plate. Make certain the line voltage where you are conforms to this requirement.
- Do not use the same socket used for any noise generating device (such as a motor or variable lighting system).
- Make sure the unit is turned off before connecting the power plug to the AC outlet.
- When disconnecting the power cord, do not pull the cord itself; grasp it by the plug. This will help in preventing short circuits. Also, protect the cord from any other possible damage, such as that caused by treading on it.
- If the unit is not to be used for a long period of time, disconnect the power cord.
- Since the product employs AC current, a reasonable amount of heat generation should be expected.
- Check with your local Roland dealer if you wish to use this unit in a foreign country.
- When connecting devices together, be absolutely sure all units have been switched off. Never connect any cables to the S-550, hard disks, or this unit while they are powered up.
- In cases when units have been powered up, and the system disk has not been inserted, yet you wish to turn off power to this device, and/or hard disk, wait for 12 to 13 seconds before doing so.
- If, due to unavoidable circumstances, you need to connect this unit to an amplifier while power is on, be sure to connect the plug(s) going to this unit first, and then make connections with the amplifier. When disconnecting, remove connections with the amplifier first.
- Operational errors can be caused by rapidly switching the unit off and then on again, or by connecting the power cord when the switch has been left at the on position. In such situations, turn power off, and allow several seconds before turning it back on.
- The unit should always be placed horizontally. Never use it in a vertical position.
- Never move the unit while power is on (while operating). Read errors may result.
- Take proper precautions in avoiding possible damage caused by improper placement of the unit. In particular the following should be avoided:
  - Places subject to extremes in temperature.  
(Such as under direct sunlight, next to heating outlets, or stacked along with heat generating units.)
  - Places where the humidity is very high.
  - Very dusty environments.
  - Places with high levels of vibration.
- When the unit has been kept in a cold place, and is moved to where it is warm, the sudden change in temperature is liable to cause condensation to form within the drive. This results in not only a deterioration in performance, but can lead to damage of the drives, as well as data on discs. Always allow several hours of time to pass before using the unit, when moving it between extremes in temperature.
- When placed adjacent to neon and fluorescent lights, TV picture tubes, CRT displays and the like, noise or errors may result. To avoid this move units to a different position.
- Operating this unit near a TV or radio may cause interference or static. If this happens, move the unit away from these devices.
- Do not place or drop anything heavy on the unit or its power cord.
- Avoid placing the unit where its air vents may be blocked or covered in any way.
- When transporting, reuse the original packaging. Remove the caddy, and pack the drive the same way as it first came. Take due precautions against vibrations and shock.
- Use a soft, dry cloth for routine cleaning. To remove fingerprints or dulling deposits, use a soft cloth slightly dampened with water and a little mild detergent. Immediately wipe dry with a soft cloth. Never apply solvents such as paint thinners, since this may ruin the finish.
- Should any foreign object, or any form of liquid accidentally be introduced to the interior of the unit, or the unit otherwise show signs of malfunction or damage, turn the power off immediately. Then take it to be checked; to the dealer where bought or to a Roland service center.

# FRONT & REAR PANEL DESCRIPTIONS

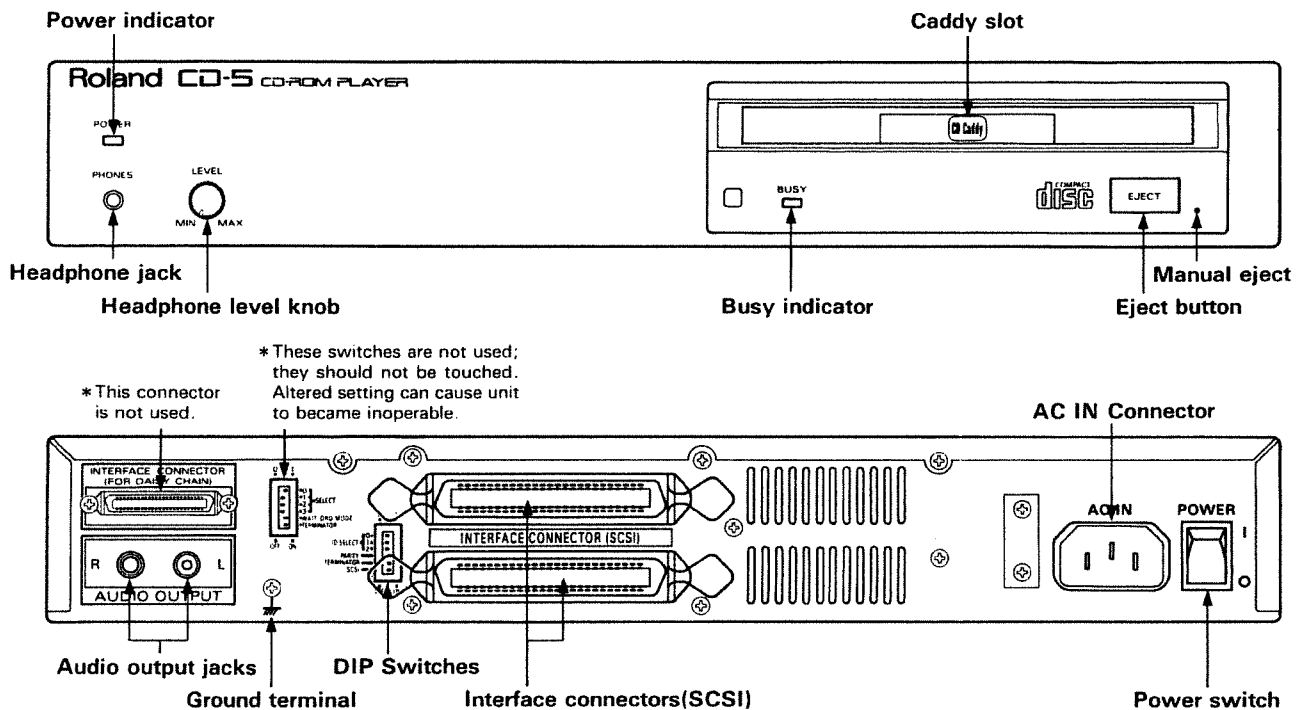

## Power Indicator

Lights up when power switch is on.

## Headphone Jack

Allows listening through mini stereo headphones when used as CD player.

## Headphone level knob

Adjusts volume level of headphones.

## Caddy Slot

Accepts insertion of caddy, with CD inside.

## Eject Button

Ejects the caddy.

## Manual Eject

Allows ejecting the caddy manually, by inserting a thin, rod-like object.

## Busy Indicator

Lights up with varying intensity while data is being read from disc. Also lights while operated as CD player.

## Interface Connector (SCSI)

Used to connect specialized cables for connection with the S-550, another CD-5, or hard disks.

## DIP Switches

Set assignment of individual ID numbers for each drive.

## Audio Output Jacks

Outputs a stereo audio signal when used as a CD player. Can be connected to the CD or AUX inputs on an amplifier.

## Ground Terminal

When used as a CD player, and your mixer or amp is equipped with a ground terminal, it should be used to make a grounding connection.

## Power Switch

Turns the unit on or off.

## AC IN Connector

Provides connection of the supplied AC power cord.

## ■ HANDLING OF DISCS AND THE CADDY

Since the caddy serves in protecting your discs, take note of the following points.

### Inserting Discs

1. Press on the tabs on both sides of the caddy and open its lid.

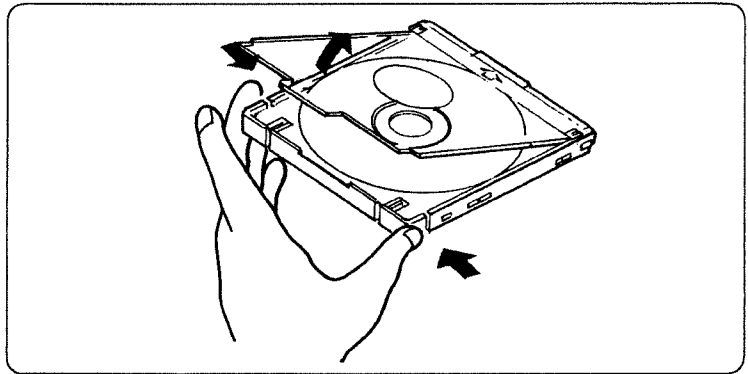

2. With the label on the disc facing upwards, place it onto the caddy, as shown. Never touch the reverse side (recorded surface) of the disc.

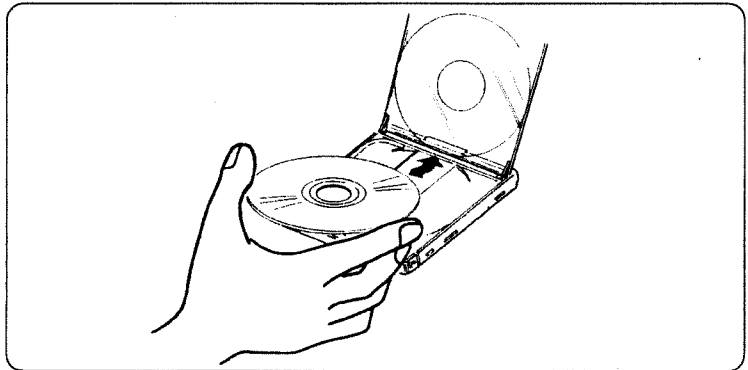

3. Close the lid firmly, checking that it snaps in place.

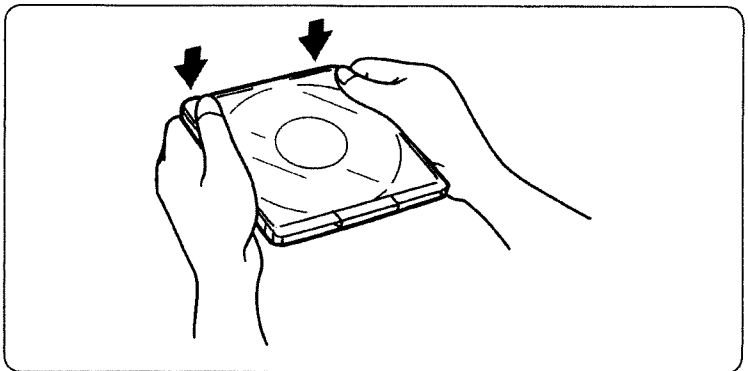

## Precautions

- Never touch, or get scratches on the reverse side of the disc (the side with the recorded signals). Otherwise, the data may become unreadable.
- Do not drop or in any other way apply shock to the discs and caddy.
- The shutter is designed to open automatically when the caddy is inserted into the drive. Never open it by hand and risk touching the disc.

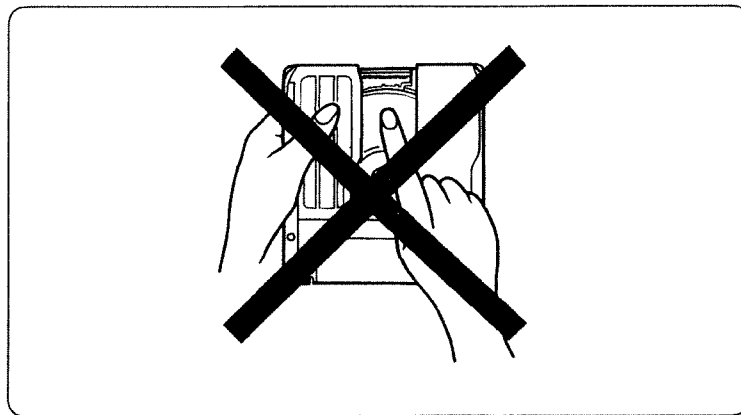

- When transporting the unit, remove the caddy from the drive.
- Never allow discs or caddy to remain in places that :
  - are subject to extremes in temperature.  
(Such as under direct sunlight, next to heating outlets, or stacked along with heat generating devices.)
  - reach very high humidity
  - are very dusty
  - are subject to high levels of vibration.



## Inserting the caddy

1. After confirming that connections are properly setup, turn on power to the CD-5.
2. The caddy is inserted into its slot as shown in the illustration. The caddy is mounted automatically.

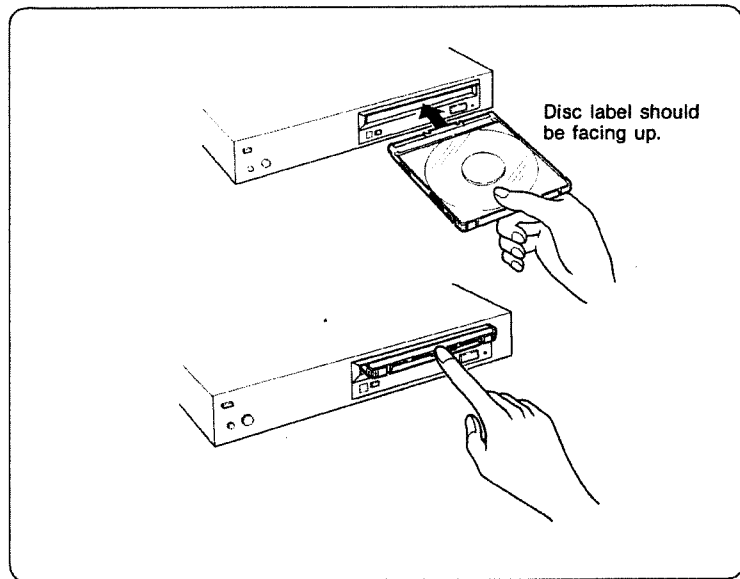

The busy indicator lights up.

\*Whenever the disc is incapable of being read, such as it is not placed properly in the caddy, or the type of disc is wrong (CD-ROM vs. audio), the caddy will be ejected.

3. When the busy indicator has gone out, it is then ready for transfer of data with the S-550.

## Ejecting the caddy

Press the eject button.

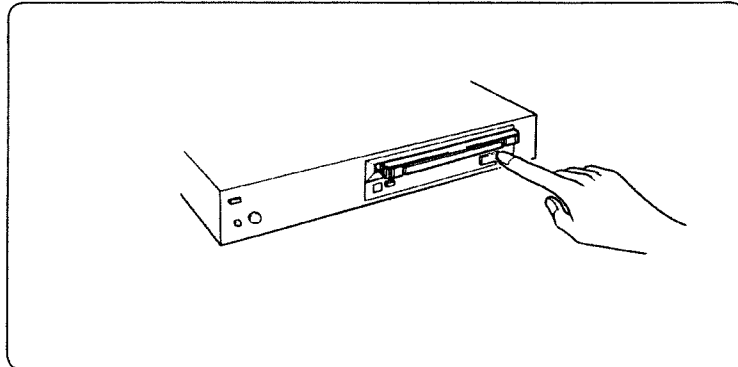

\*When the software has disabled use of the eject button, nothing will happen when you press it. See pages 28, 42, and perform the "CD Eject" command.

### ●Ejecting the caddy manually

1. Switch off power to the CD-5.

2. Insert a narrow rod-like instrument (approx. 1.2mm in diameter) into the manual eject hole, and press firmly.

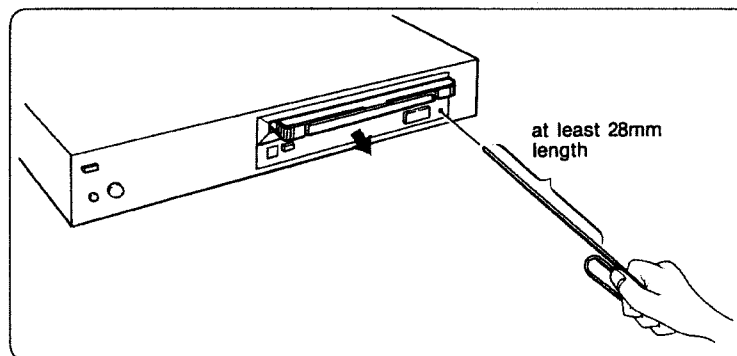

\*Make sure power is off. Manually ejecting the caddy while power is on can cause malfunction.

# 1 Setup

The S-550 can be connected to the CD-5, as well as to hard disks. Depending on the individual configuration, the setup procedure will be different, so follow the procedure required as follows :

## ● Connection of single CD – 5



Carry out setup explained in "Single CD-5 configuration", page 12.

## ● Connection of CD – 5 and hard disk

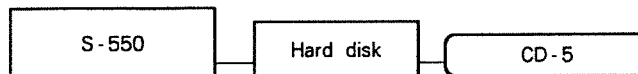

Carry out setup explained in "Configuration with CD-5 plus hard disk", page 18.

## ● Connection of multiple CD – 5s or hard disks

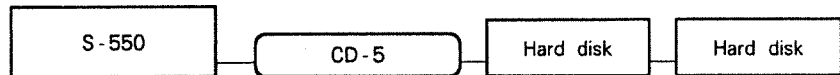
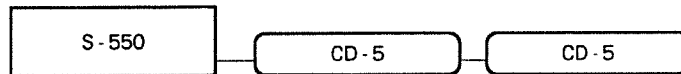

A multiple configuration can be made that includes more than one CD-5 and hard disk. However, the S-550 can access only one each, CD-5 and hard disk, at any time.

For setup of such configurations, refer to "When connecting multiple CD-5s or hard disks", page 26.

\*No more than 4 devices can be connected to the S-550 at once. Note also that in such cases, make sure total cable length does not exceed 6.5meters to ensure normal operation.

## ■ Single CD - 5 configuration

A certain amount of preparation is necessary before using the CD-5. Follow the procedures as outlined in the following.

### 1. Installing interface board (HD5-IF) in the S-550

The optionally available interface board (HD5-IF) needs to be installed in the S-550. First, make sure the S-550 power is off, and unplug its power cord.

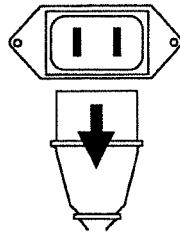

Have parts supplied with the HD5-IF ready.

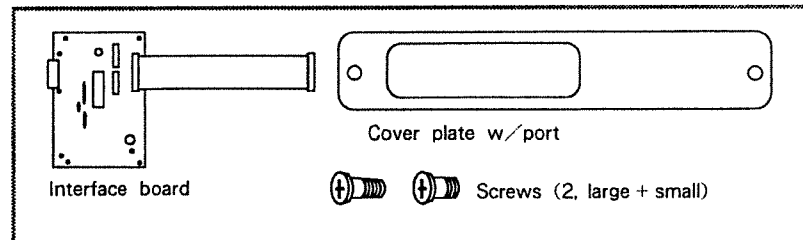

The system disk provided with the HD5-IF will not be used.

Take careful note of the following precautions before installing the interface board :

- \* Do not remove any screws other than those indicated.
- \* Do not touch the soldered surface of the board.
- \* The interface board is quite sensitive to static electricity. To avoid damage, take great care in handling it in places where there is a buildup of static electricity.

Using a Phillips screwdriver install the interface board as directed below.

- Step 1 Take out the 2 screws holding it, and remove the small cover plate from the rear panel of the S-550.



- Step 2 Turn the S-550 upside-down, and remove the 11 screws holding the bottom cover. Remove the cover.

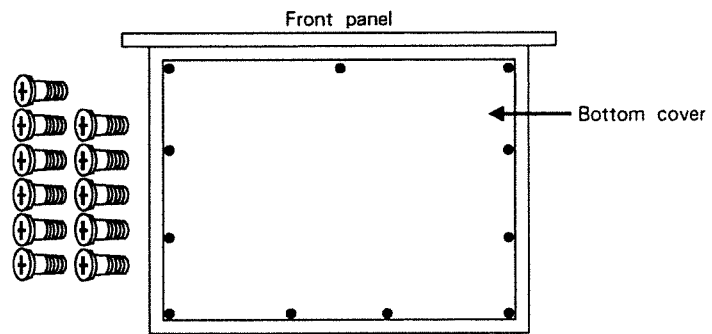

- Step 3 Place the interface board in position as shown in the diagram.

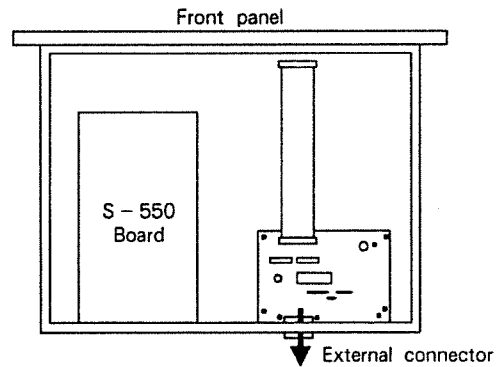

\* Do not touch the existing internal board of the S-550.

■ Single CD-5 configuration

Step 4 Fasten the interface board in place.

- Ⓐ Align the holes in the board with the bushings, and push down so it is fitted in place.
- Ⓑ Use supplied long screws to fasten here.
- Ⓒ Use the short screws to fasten here.

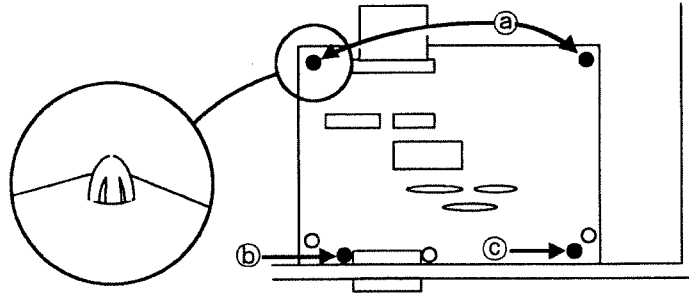

Step 5 Connect the internal connector.

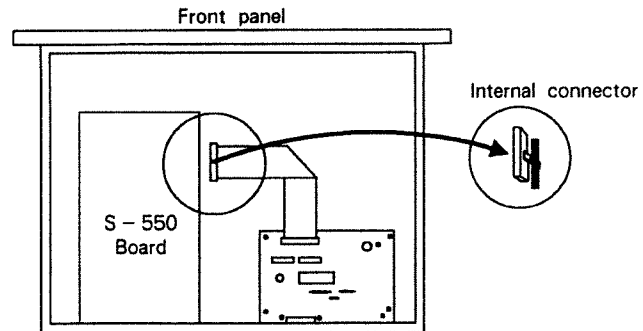

Step 6 Replace the bottom cover as found originally.

Step 7 Attach the supplied cover plate.

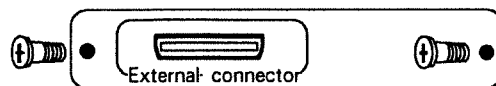

## 2. Interconnection

Connect the cable going from the external connector on the S-550 to the interface connector on the CD-5. (It doesn't matter which of the two on the CD-5 you use.)

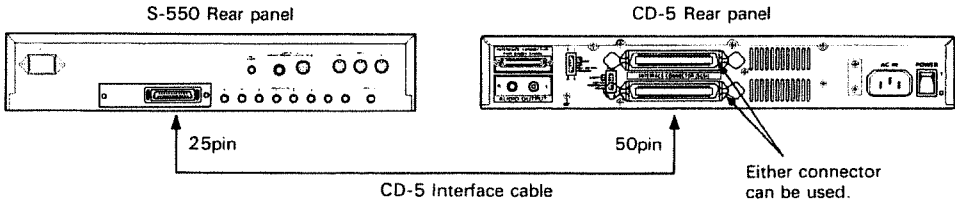

Use the interface cable supplied with the CD-5 (25 pin to 50 pin).

- \* See rear of this manual for diagram of pin connections on the CD-5 interface connector.
- \* For details of pin connections on the HD5-IF, see page 52 in the HD5-IF owner's manual.

### About the switches on the rear panel

Do not touch the switches on the CD-5's rear panel. Any alteration of their settings can cause malfunction.

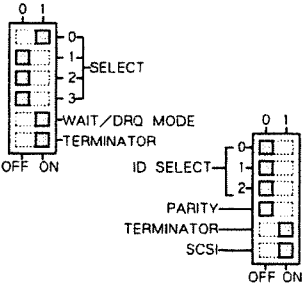

### 3. Startup

---

When connections have been completed, you are ready for startup.

- Step 1 Turn on power to the S-550. Wait until you see the prompt, **"Please Insert System Disk"**.
- Step 2 Turn on power to the CD-5.
- Step 3 Insert the caddy, containing a disc, into the CD-5. Wait for 12 to 13 seconds.
- Step 4 Now insert the CD-5 System Disk into the S-550 to boot it up.

The PLAY mode display should appear, indicating that the startup (boot) is completed.

**\* Always make sure that when you switch between power-on and power-off, with both the CD-5 and S-550, you allow 12 to 13 seconds before again switching on or off. Otherwise, damage may result from too rapid switching between the on and off states.**

\* Should any abnormalities occur during operation, refer to the section on Troubleshooting, and take measures to remedy the situation.

### 4. Confirming connections are in order

---

Check to make sure the CD-5 and S-550 are properly connected.

How : From the **"Setup"** menu in the DISK mode, open the command window. Then, execute the command **"SCSI Check"**.

The figure below shows what you should see if the connections check out positively. If you don't see this display, try the **"SCSI Check"** command again. If there is still no display shown, refer to the Troubleshooting section at the rear.

<b>* SCSI Device Connection Check *</b>			
<b>I/F check OK</b>		<b>ID=3</b>	<b>N.C.</b>
<b>ID=6</b>	<b>N.C.</b>	<b>ID=2</b>	<b>N.C.</b>
<b>ID=5</b>	<b>N.C.</b>	<b>ID=1</b>	<b>N.C.</b>
<b>ID=4</b>	<b>N.C.</b>	<b>ID=0</b>	<b>CD-5</b>

Should the message **"NG"** be displayed, also refer to the Troubleshooting section.



## 5. Startup settings

---

If you wish, you can configure the CD-5 System Disk so that certain controllers, such as the panel buttons on the S-550, a mouse (MU-1), or RC-100 will be activated upon startup.

Step 1 Select the **"Setup"** menu in the DISK mode.

Step 2 Make the parameter settings.

● **S/Controller** [ Off, MU1, RC]

Select which means of control should be used, either panel buttons on the S-550, the mouse (MU-1), or RC-100.

\* You do not need to alter settings concerned with hard disks, which are : **"S/Load I ← Area"**, **"S/Load II ← Area"**, and **"S/Load (P. CHG)"**.

\* Settings for **"Hard Disk ID"** and **"CD-5 ID"** cannot be written to the system disk.

Step 3 Execute the **"FD Save SYS"** command.

Hereafter, follow the instructions in **"3. Startup"**, page 16, and each time you startup, the settings made here will come into play.

## 6. Shutting Down

---

When shutting down, turn power off as follows :

Step 1 Remove the caddy as explained on page 10.

Step 2 Turn off power to the CD-5.

Step 3 Turn off the power on the S-550.

## ■ Configuration with CD-5 plus Hard Disk

A certain amount of preparation is necessary before using the CD-5 together with a hard disk. Follow the procedures as outlined in the following :

### 1. Installing interface board (HD5-IF) in the S-550

Install the HD5-IF interface board in the S-550. The procedure for doing this is identical to that explained in "Single CD-5 configuration", page 12.

- If you have already installed the HD5-IF, perhaps by referring to its manual, start from the next step, "2. Setting ID numbers".

### 2. Setting ID numbers

In order for the S-550 to differentiate among various peripherals you may have connected, each peripheral device needs to be assigned an ID number.

On the CD-5, the "ID SELECT" DIP switches on its rear panel are used to set the ID number.

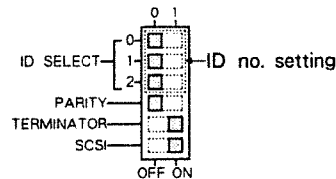

The various combinations of possible switch settings produce ID number settings as shown below :

ID number	0	1	2	3	4	5	6	7	
ID SELECT	0	0	1	0	1	0	1	0	1
	1	0	0	1	1	0	0	1	1
	2	0	0	0	0	1	1	1	1

ID no. "7" must not be used

Check that it is set for "0", the factory setting.

Check the respective owner's manual for the ID number of the hard disk.

Should any hard disk have the ID number 0, you will need to change either it or the CD-5's ID number so they do not conflict.

When changing the ID number of the CD-5 make certain its power is off. Leaving power on while making setting changes can cause malfunction.

If you have changed the CD-5 ID number, make note of the new number on the supplied sticker, and affix it as illustrated for future reference.

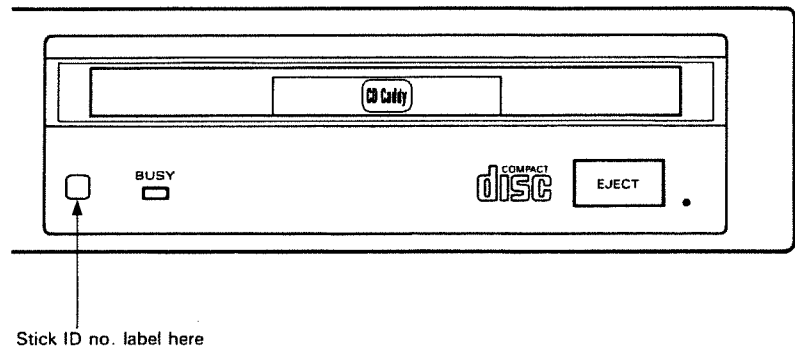

Stick ID no. label here

- \* **Never assign ID number 7. This is the ID number for the S-550 (permanent). All ID number settings for the CD-5 and hard disk must be within the range of 0 to 6, with a separate number for each.**
- \* **Do not touch any other switches. Tampering with settings can cause malfunction.**
- \* **Refer to the manual for your hard disk drive for information on setting its ID number.**

### 3. Interconnections

You need to make connections between the external connector on the S-550, the CD-5's interface connector, and the hard disk connector. (It doesn't matter which of the 2 connectors available on the CD-5 and hard disk you use.)

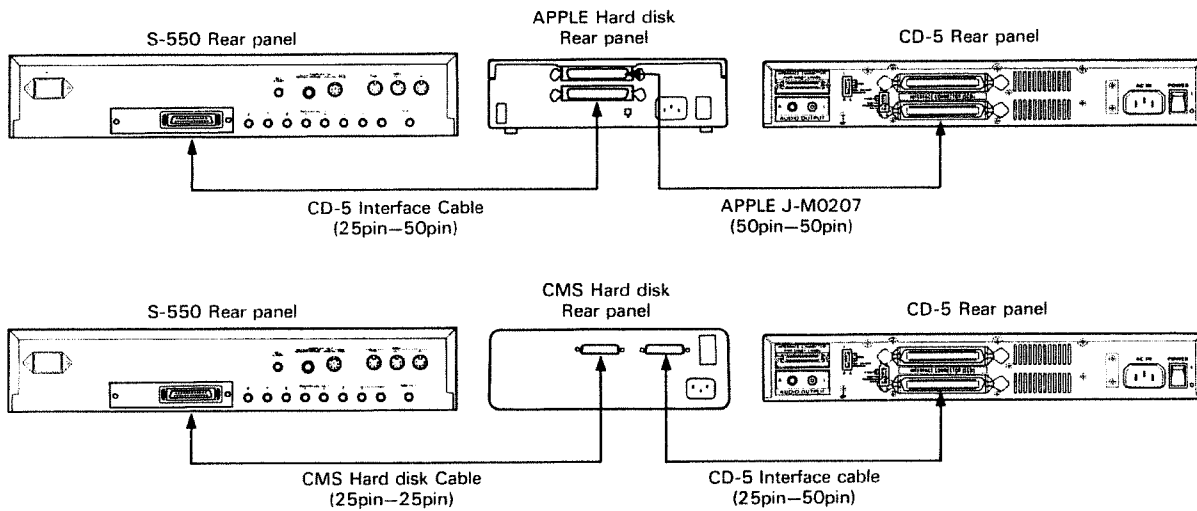

- \* For the CD-5 use the supplied interface cable (25 pin to 50 pin).
- \* When using an Apple hard disk, you will need the cable supplied by Apple Computer, Inc., part # J-M0207 (50 pin to 50 pin).
- \* For details of pin connections on the CD-5 interface connector, see specifications at rear of this manual.
- \* For information on pin connections on the HD5-IF external connector, see page 52 in the HD5-IF owner's manual.

## 4. Startup

---

After connections are completed, the CD-5 System Disk is used for startup.

- Step 1 Turn on power to the S-550. Wait until you see the prompt, "**Please Insert System Disk**".
- Step 2 Turn power on to both CD-5 and hard disk.
- Step 3 Insert the caddy, containing disc, into the CD-5. Wait for 12 to 13 seconds.
- Step 4 Insert the CD-5 System Disk into the S-550 for startup.

When you see the display for the PLAY mode, startup is completed.

\* **Always make sure that when you switch between power-on and power-off ; with the CD-5, hard disk and S-550, you allow 12 to 13 seconds before again switching on or off. Otherwise, damage may result from too rapid switching between the on and off states.**

\* If the access indicator on the hard disk remains continuously lit, turn power to the hard disk off, and then on again.

## 5. Confirming connections are in order

---

A check should be performed to determine if all connections are in order, and the S-550, CD-5, and hard disk are ready for normal operation.

- Step 1      Go to the DISK mode and select the "Setup" menu.
  
- Step 2      Open the Command window and execute the command "SCSI Check".

"Hard Disk" and "CD-5" will appear as shown in the illustration. Should this not be displayed, try the "SCSI Check" command once again.

<b>* SCSI Device Connection Check *</b>			
<b>I/F check OK</b>		<b>ID=3</b>	<b>N.C.</b>
<b>ID=6</b>	<b>N.C.</b>	<b>ID=2</b>	<b>N.C.</b>
<b>ID=5</b>	<b>N.C.</b>	<b>ID=1</b>	<b>Hard Disk</b>
<b>ID=4</b>	<b>N.C.</b>	<b>ID=0</b>	<b>CD-5</b>

\* If "NG" is displayed as the result alongside "I/F check", there is an improper connection between the HD5-IF and S-550 internal connector; or the HD5-IF itself is faulty. Refer to Troubleshooting section.

## 6. Hard disk setup

---

### When using the hard disk for the first time

When using the hard disk for the first time with the S-550, you need to format (initialize) it specifically for use with the S-550.

The following is performed upon formatting :

- Checks are run to make sure the connections between S-550, CD-5 and hard disk are all in order.
- The hard disk becomes dedicated to the S-550.
- Parameters are set at default values.
- The CD-5 System (including utilities) is saved onto the hard disk.

How :

From the DISK mode, and its "Setup" menu, open the Command window and execute the "HD Format" command.

"Formatting" will be displayed in the message line.

\* Should "HD Connection Error" be displayed as the message, see Troubleshooting, page 47.

\* If "HD Connection Error" is repeatedly displayed, call your nearest Roland service station.

When "Complete" is displayed in the message line, formatting has been successfully completed. (Formatting takes several minutes.)

With completion of formatting, the capacity of the connected hard disk (how much memory is available to you) is displayed alongside "HD Capacity".

### When the hard disk is already formatted for the S-550

With a hard disk already formatted for the S-550, you still need to save the System Disk (including utilities) provided with the CD-5 onto the hard disk in order to use it together with the CD-5.

The following procedure saves the CD-5 System onto the hard disk :

How :

From the DISK mode and its "Setup" menu, open the Command window and execute the command "HD Save SYS".

During the HD save procedure, "Saving System" → "Working" will be displayed in the message line.

When "Complete" is displayed it has finished.

## 7. Startup settings

---

Standard settings, that are activated upon startup, can be written to the CD-5 system disk as follows :

Step 1 In the DISK mode, select the "Setup" menu.

Step 2 Parameters, as shown below, are set.

● S/Load I ← Area [H11 - H \*\*, Off]

● S/Load II ← Area [H11 - H \*\*, Off]

You can have sound data from a designated Area on the hard disk loaded upon startup. For each block, I and II, determine the Area of the sound data to be loaded. If set at "Off", no loading takes place at startup.

\* For a detailed explanation of Areas, see page 11 in the HD5-IF owner's manual.

● S/Load (P.CHG) [1 - 16ch, Off]

During performance, you can receive MIDI program change data, and load sound data from the hard disk (Load Set). You need to set the channel at which MIDI program change data will load sound data.

\* For detailed explanation of the relation between program change numbers and Areas loaded, refer to page 37 in the HD5-IF owner's manual.

\* Set for a MIDI channel not being used in the performance. If you use the same channel used in performance, patches will change respective to program change messages, but the sound data will not be loaded.

● S/Controller [Off, MU1, RC]

Here you determine which means of control will be used ; either the S-550 panel buttons, the mouse (MU-1), or RC-100.

\* Settings for "Hard Disk ID" and "CD-5 ID" are not written to the system disk.

Step 3 Execute the "FD Save SYS" command.

The contents of the 4 parameters are thus saved onto the CD-5 System Disk along with the system program.

Hereafter, simply by carrying out the procedure outlined in "4. Startup", page 21, startup will take place in accord with the settings you made here.



## 8. Shutting down

---

When turning off power to the hard disk, make sure you perform the following procedure.

**\* If you fail to perform the "HD Park Heads" command before shutting down, you may cause damage.**

- Step 1 Remove the caddy, as explained on page 10.
- Step 2 In the DISK mode select the **"Setup"** menu.
- Step 3 Open the Command window, and execute the **"HD Park Heads"** command. **"Complete"** will appear in the message line indicating that the hard disk heads are in their safe, standby position, or **"parked"**.
- Step 4 After you've been given the **"Complete"** message, you can turn off power to the S-550, hard disk, and CD-5.

After the heads in the hard disk have been parked, you can no longer transfer data between the S-550 and hard disk. Should you wish restart the hard disk, proceed as shown below.

- How : From the DISK mode's **"Setup"** menu, open the Command window, and execute the **"HD Restart"** command.

When **"Complete"** appears in the message line, the hard disk will be in the state it normally is when power is turned on.

After the setup procedures explained so far have been completed, each time you use the equipment you only need to perform the bootup and SCSI Check.

## ■ When connecting multiple CD-5s or hard disks

### About connections

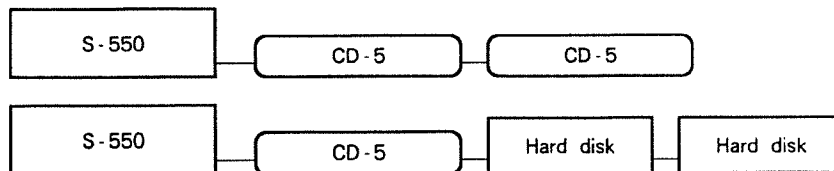

\* The maximum number of devices that can be connected to the S-550 is four. Make sure the total length of interconnecting cables does not exceed 6.5 meters to assure normal operation.

**At any time, the S-550 is capable of data transfer only with one each of the CD-5s and hard disks.**

### Booting

With multiple devices that are identical in manufacture connected, upon startup the S-550 will ready itself for data transfer with the device having the **highest ID number**. (see page 18)

### Checking the ID numbers of connected devices

You can view a listing of ID numbers for connected devices.

How :

In the DISK mode, select the "Setup" menu then, open the Command window and execute the "SCSI Check" command.

The S-550 searches for the ID numbers of all connected hard disks and CD-5s, and displays them for 10+ seconds as shown below.

```
* SCSI Device Connection Check *
I/F check OK      ID=3  N.C.
ID=6  N.C.        ID=2  Hard Disk
ID=5  N.C.        ID=1  Hard Disk
ID=4  N.C.        ID=0  CD-5
```

### Active device Change

When you wish to carry out data transfer with devices having low ID numbers: First perform a check of ID numbers as explained above, then move the cursor to either "Hard Disk ID" or "CD-5 ID" parameters, and set the ID number.

\* If you choose an ID number different from one set for either hard disk or CD-5, "SCSI Check" is displayed, and no data transfer can be carried out. Thus you should always change to a set ID number.

### Startup settings

Among startup settings you have made (see page 24 ), those for the hard disk with the highest ID number are valid.

### Shutting down

When you have 2 or more hard disks connected, when shutting down you need to perform "Park Heads" on each one. Use "Active Device Change", and park the heads on all hard disks, then turn power off.

## ② Loading sound data from the CD-5

This section covers loading of data from the CD-5.

\* Concerning transfer of data with hard disks, the procedure is identical to that for the HD5-IF System, so refer to the HD5-IF owner's manual.

### **Areas on the CD-5**

CD-ROMs containing sound data become the source from which to load. On a CD-ROM, data equivalent to the content of 1 floppy disk is termed as an Area. These Areas are organized in a numbered sequence, represented by "**# number.**" Areas of the same general type of sound form what are called "**Groups.**" Groups also are numbered and represented by "**# number.**" If you select the Group first, then look for an Area, you will be able to much more quickly find the Area you need.

# 1. Loading sound data

The following will load a volume equivalent to one floppy disk from the CD-5 to the S-550.

Step 1 In the UTIL mode, select the "CD Load" menu.

Step 2 Make settings for the following parameters.

- I ← CD Area # (Group #)
- II ← CD Area # (Group #)

Select the Area on the CD-5 you wish to load to Block I, Block II.

\* If you look for the Area you want after selecting a Group, it becomes much easier to select the Area you wish to load.

If you move the mouse cursor to a Block's Area or Group and change the value, the display will respond to such changes, and a listing of Area or Group names will be displayed. On the display, on the line below the parameters, the name of the currently selected Area is displayed.

Step 3 Open the Command window, and select a command.

CD Load Chain	Loads data from 2 Areas in one continual operation (Chain Loads).
CD Load Set I	Loads sound data from the Area set in "I ← CD Area" (including PLAY, FUNC, & MIDI mode parameters) to Block I.
CD Load Set II	Loads sound data from the Area set in "II ← CD Area" (including PLAY, FUNC, & MIDI mode parameters) to Block II.
CD Load Block I	Loads sound data from the Area set in "I ← CD Area" (excluding PLAY, FUNC, & MIDI mode parameters) to Block I.
CD Load Block II	Loads sound data from the Area set in "II ← CD Area" (excluding PLAY, FUNC, & MIDI mode parameters) to Block II.
CD Load Func I	Loads function data from the Area set in "I ← CD Area" (parameters for PLAY and FUNC modes).
CD Load MIDI I	Loads MIDI data from the Area set in "I ← CD Area" (parameters for MIDI mode).
CD Eject	Ejects caddy containing the CD.

Step 4 Execute the command.

"Now Loading" will be displayed on the message line.  
When loading has finished, "Complete" is displayed.

## 2. Loading Patches

The following loads 1 patch from the CD-5 to the S-550. There are two methods ; one loads solely the patch parameters , and the other simultaneously loads Tone parameters and Wave data for tones used by the patch.

\* Concerning load of patches from floppy disks, see page 39.

### Loading only patch parameters

The following selects one patch from a designated Area contained on the CD-ROM, and loads the parameters for the patch into the S-550.

Step 1 In the UTIL mode, select the "CD Load P" menu.

Step 2 Set the following parameters :

● **CD Area # (Group #)**

Select the Area which contains the patch you wish to load.

● **CD P #**

Select the number of the patch you wish to load from the selected Area.

● **Int P # (Del #)**

Select which patch number on the S-550 you wish to load to.

● **Used Tone Only**

Since this is a parameter concerned with deletion of patches, it has no relevance when loading.

\* If you move the mouse cursor to either Area, Group, or Number and change a value, the display responds to the change, and shows a listing of Area, Group, or Patch names. At "Parameter" on the display will be shown the name of the currently selected Area or patch.

Step 3 Open the Command window and execute the "CD Load P.PRM" command.

"Now Loading" will be displayed on the message line.

When loading has finished, "Complete" is displayed.

### Loading tones used in a patch at the same time

Instead of just the patch parameters, you can also simultaneously load the tones (tone parameters and wave data) used in a patch.

This procedure does not cause loss of any tone data already contained in memory on the sampler. Data loaded is directed to the empty regions of memory.

Normally tones will be loaded to the tone number corresponding to their original number, but this may vary as follows depending on the circumstances within the sampler's memory.

- When tone numbers of the patch being loaded are also in use on the sampler :

It is loaded under tone numbers not being used on the sampler, and at the same time the tone numbers assigned within the patch are revised. Thus, there is no need for redoing split settings.

- When the unused number of tones in the sampler's memory are not enough to cover the amount used by the patch being loaded :  
"Memory Full" is displayed, and the load is aborted.

- When the space limitations of the sampler's Wave banks prevent all the tone Wave data from being loaded :

Loading takes place from tone number 11. When Wave bank A becomes full, it moves to Wave bank B. If it doesn't fit into bank B, "Memory Full" is displayed, and the load is terminated. It then displays a list of the tones that couldn't be loaded. When you wish to load these remaining tones, delete unnecessary tones in the same block, and use the "Load Tone" function to load them one at a time.

- When loading two patches from the same Area :

When the same tone is used by 2 patches, it is loaded each time. Thus, the same tone will be loaded twice.

- When loading sub-tones :

When loading sub-tones, and in the same patch the original tone is used as well, it automatically becomes a sub-tone.

When the original tone is not being used in the same patch, automatically the original tone is loaded as well, and it becomes a sub-tone.

\* All tones will be loaded to the block identical to the block of the destination patch number.

Step 1 In the UTIL mode, select the "CD Load P" menu.

Step 2

Set the following parameters.

● CD Area # (Group #)

Select the Area which contains the patch you wish to load.

● CD P #

Select the number of the patch you wish to load from the selected Area.

● Int P # (Del #)

Select the destination patch number on the S-550.

● Used Tone Only

This is a parameter valid only for deletion of patches. (See page 41)

\* If you move the mouse cursor to either Area, Group, or Number and change a value, the display responds to the change, and shows a listing of Area, Group, or Patch names. At "Parameter" on the display will be shown the name of the currently selected Area or patch.

#### Checking the Tone List

Open the Command window and give the command "CD Load T.List" to check usage status for the tones of the source patch and the destination block.

[CD] Tones used by the patch selected in "CD P #" are displayed. Those indicated with "Org" are original tones used in the patch, and those with "Sub" are sub-tones used in the patch. Those indicated with " --- " are tones not used by that patch.

[I] Tones in the S-550 are displayed. Those tones with the " \* \*" indicator can be loaded, those with " --- " cannot. With the display at this point, moving the mouse cursor returns you to the original display.

Step 3

Open the Command window, and execute the "CD Load Patch" command.

"Now Loading" will be displayed on the message line.

When loading has finished, "Complete" is displayed.

When all of the tones could not be loaded, it displays a list of the tones that weren't. When you wish to load these remaining tones, delete unnecessary tones in the same block on the sampler, and use the "Load Tone" function to load them one at a time.

### 3. Tone loading

The following selects any desired tone from an Area in memory on a CD-ROM, and loads that tone's parameters and wave data.

Step 1 From UTIL mode, select the "CD Load T" menu.

Step 2 Set the following parameters :

● **CD Area # (Group #)**

Select the Area which contains the tone you wish to load.

● **CD T #**

Select the number of the tone you wish to load from the selected Area.

● **Int T #**

Select which tone number on the S-550 you wish to load to.

● **Wave Bank [A,B]**

Writes wave data to a wave bank in the block set in "Int T #." Here, you set which Bank, A or B, is the destination of the write.

\* If you move the mouse cursor to either Area, Group, or Number and change a value, the display responds to the change, and shows a listing of Area, Group, or Tone names. (Original tones in white; sub-tones in red) At "Parameter" on the display will be shown the name of the currently selected Area or tone (wave bank, time).

If the destination of the load is a tone number that is an original tone, the following process takes place inside the S-550 :

- Existing wave data is erased, increasing free space (Remaining Time).
- The wave data read in is written to the free space.
- The tone parameters read in are copied.
- Sub-tones borrowing on wave data are initialized and become unused sub-tones.

When there is no space at all in the write destination's wave bank, "Cannot Execute" is displayed, and the load is aborted. When there is some space, but not quite enough, the command can be performed; but be careful since some wave data may be missing. As a reference in checking the amount of space for a write, the currently remaining free space for each Wave Bank (Remaining Time) is displayed in terms of time in seconds at a 30kHz sampling rate.

Step 3 Open the Command window and execute the "CD Load Tone" command.

"Now Loading" will be displayed on the message line.

When loading has finished, "Complete" is displayed.



## ③ Revisions over S-550 VER. 1.0

The System Disk provided with the CD-5 is not simply a combination of the S-550 system, plus programs that function in operating the CD-5 and hard disks, but has been revised overall, with new functions being added in order to offer improved performance and ease of use.

Here explained are the items where revisions have been made. For further information on functions, refer to the "S-550 Owner's Manual."

### 1. Input of names

(P. 73, 103, 132 in S-550 manual)

**Supports entry of tone and patch names, and disk labels through mouse selection from palette.**

How : Move the cursor to the point of insertion, press the left mouse button, and a cursor appears inside the palette. Select a character, and press the left button on the mouse to have it entered. "I" is used to insert a space ; "D" for deleting characters. The name cursor can be moved using ← or →. When you want to take the cursor out of the palette and continue normally, press the right button on the mouse.

### 2. Map input

(P. 96, 109 in S-550 manual)

**The values of a desired patch (or tone) can be copied to a separate patch (tone), allowing consecutive entry of identical values.**

How : Move the cursor to "Normal" and select "Copy." Move the cursor to the value that will be the source, and press the right mouse button. Then move the cursor to the destination value, press the left button, and copying is completed.

### 3. DC-Cut

(P. 54 in S-550 manual)

**When you haven't gotten a sound as clear as you want through sampling, due to the presence of DC current elements (low-range noise), you can select to cut out such DC-related low-range noise.**

How : In the "D.Filter" menu, open the Command window and execute the "DC-Cut" command.

### 4. Split settings

(P. 105 in S-550 manual)

**Tones can be set while viewing tone list. Tones used in that patch are displayed in white ; others in black.**

How : When assigning tones, make selection of "Type Select" for either "1st" (when changing settings for 1st tone only), "2nd" (changing 2nd tone only), "1st & 2nd" (changing both tones), or "off" (for condition where both are not set).  
To check tone assignments, select "Info" for "Type Select." When Key On messages are received, or a key is indicated by mouse on the display, arrows will appear at tones that are assigned. → indicates 1st tone, ← appears for 2nd tone.

## 5. Conversion function

(P. 147 in S-550 manual)

Not only can data disks created by the S-50 be converted for use with the S-550, but the reverse, conversion of S-550 disks for use with the S-50, can be performed as well.

- \* Between the S-50 and S-550, wave data is read identically. However, the S-550 has added functions, such as TVF, which cause differences in parameter types. Thus, converted sounds may vary to some extent.
- \* Data originally intended for the S-330 does not need conversion; from the menu in the DISK mode loading and saving can be performed normally.

Getting ready :  
ready :

Select the "Convert" menu in the UTIL mode, and the command window opens.

### Convert Load

#### Load I ← S-50

After processing of block data on the S-50 disk so it can be used on the S-550, it is loaded to block [I].

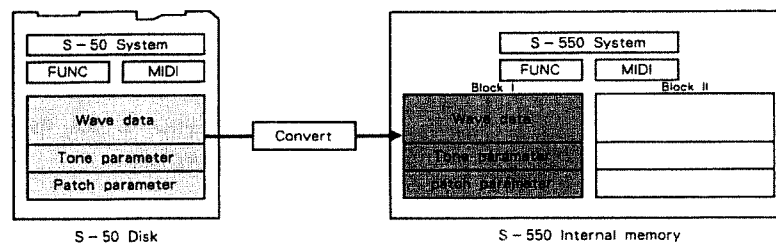

#### Load II ← S-50

After processing of block data on the S-50 disk so it can be used on the S-550, it is loaded to block [II].

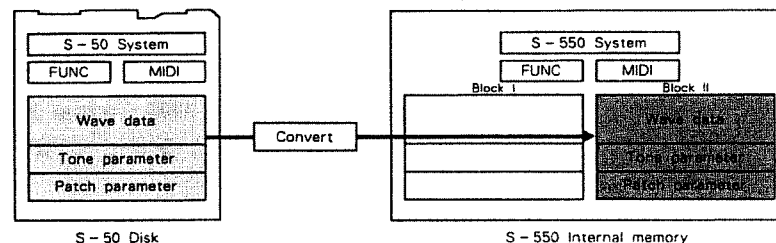

Step 1 Insert the S-50 system disk in the drive.

Step 2 Select either "Load I ← S-50" or "Load II ← S-50", then give the command using either the EXECUTE button or the left button on the mouse.

"Now Loading" will be displayed on the message line.  
 When the number reaches 00, "Complete" is displayed.

**Convert Save  
 Save I → S-50**

While converting block I data on the sampler so it is compatible with the S-50 (Ver. 2.0), it saves it to an S-50 (Ver. 2.0) disk.

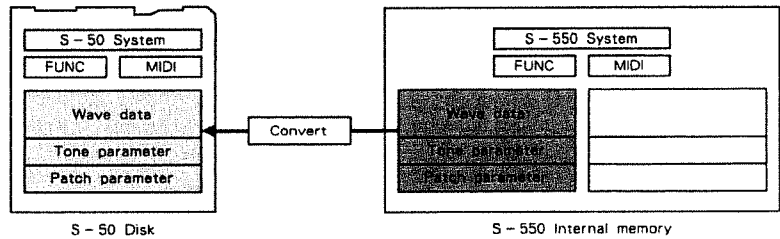

**Save II → S-50**

While converting block II data on the sampler so it is compatible with the S-50 (Ver. 2.0), it saves it to an S-50 (Ver. 2.0) disk.

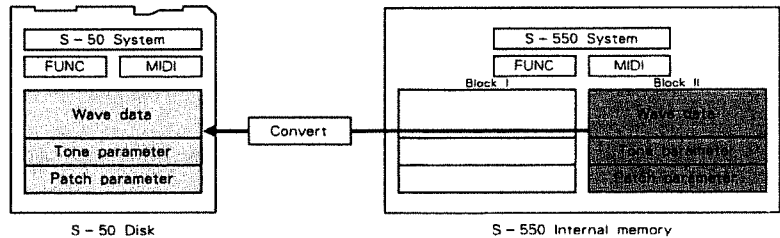

\* With S-550 disks, the patches 11 – 18 and 21 – 28 go on one disk, whereas with the S-50 there are only patches P1 – P8, thus patches 21 – 28 are ignored.

Step 1 Take a disk formatted on the S-50 (Ver. 2.0), put its protect tab in the WRITE position and insert it into the drive.

Step 2 Select either "Save I → S-50" or "Save II → S-50", then give the command using either the EXECUTE button or the left button on the mouse.

"Now Loading" will be displayed on the message line.  
 When the number reaches 00, "Complete" is displayed.

Step 3 Take the disk out of the drive and put its tab back to the PROTECT position.

### Conversion of S-50 disks to S-550 disks

#### Conv → S-550

Disks created on the S-50 are converted for use with the S-550. Processing necessary for employing sound data in the same way on the S-550 is performed.

Disks converted in this way will not include the system, so they cannot be used for booting. After booting with the S-550 system disk, sound data should be loaded from such converted disks. Note also that even if, from the DISK mode's "Setup" menu, you give the command "FD Save SYS", such sound data disks cannot accept installation of the system.

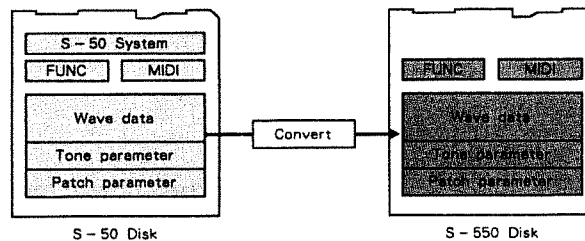

\* The procedure is carried out directly on the disk, and thus does not alter any data contained in the sampler itself.

Step 1 Take an S-50 disk that you wish to convert, move its protect tab to the WRITE position, then insert it in the drive.

Step 2 Select "Conv → S-550" and use either the EXECUTE button or the left button on the mouse to start.

\* If you insert a disk other than one for the S-50, "Insert S-50 Disk" will be displayed.

In the message line will be displayed "Working", then "Complete" when finished.

Step 3 Take the disk out of the drive and put its tab back to the PROTECT position.

**Conversion of S-550 disks to  
S-50 (Ver. 2.0) disks  
Conv → S-50**

Data on disks created by the S-550 is converted and rewritten for use on the S-50 (Ver. 2.0). The processing necessary to allow sound data to be used the same way on the S-50 (Ver. 2.0) is performed.

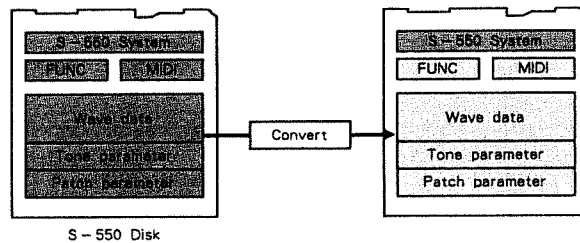

- \* The procedure is carried out directly on the disk, and thus does not alter any data contained in the sampler itself.
- \* Converted disks will have only their data prepared for use with the S-50 (Ver. 2.0). The system will remain as it is, so you won't be able to use them to boot the S-50. What you need to do is boot the S-50 with System Ver. 2.0, then use the command **"SAVE SYS"** on converted disks ; then they can be used for booting.
- \* With S-550 disks, the patches 11 - 18 and 21 - 28 go on one disk, whereas with the S-50 there are only patches P1 - P8, thus patches 21 - 28 are ignored.
- \* Regarding settings for Multi-Patch on the S-550 : Those that are compatible with the S-50 (Ver. 2.0) remain the same, and those that aren't are changed to a suitable value. You should recheck settings and alter them where necessary.

Step 1 Take an S-550 disk that you wish to convert for use with the S-50 (Ver. 2.0), move its protect tab to the WRITE position, then insert it in the drive.

Step 2 Select **"Conv → S-50"** and use either the EXECUTE button or the left button on the mouse to start.

In the message line **"Working"** will be displayed, then **"Complete"** when finished.

Step 3 Take the disk out of the drive and put its tab back to the PROTECT position.

**6. Transfer of data with floppy disks**

(P. 121 in S-550 manual)

In the CD-5 System, floppy-disk-related operations are differentiated from CD-5 and hard disk operations by the prefix "FD", which appears with menus and commands. The content of menus and the procedures are mostly identical to those of the S-550 System Disk, so refer to the chart below and then see your S-550 owner's manual. (However, since "FD Backup" and "SYS. Backup" are different from those in S-550 Ver. 1.0, see page 41, "FD Backup" page 45 "Sys. Backup".

\* "CD" refers to the CD-5; "HD" to hard disk.

System supplied with S-550	CD - 5 System
Load	FD Load
Load P. PRM	FD Load P
Load Tone	FD Load T
Label Set	Set Label
Save	FD Save
Save P. PRM	* This function does not exist.
Format	FD Save command "FD Format"
Backup	FD Backup
Change SYS	Change SYS command "FD Change SYS"
UTL. Backup	SYS. Backup

## 7. Loading Patches

(P. 126 in S-550 manual)

**Instead of just the patch parameters, you can also simultaneously load the tones (tone parameters and wave data) used in a patch.**

This procedure does not cause loss of any tone data already contained in memory on the sampler. Data loaded is directed to the empty regions of memory.

Normally tones will be loaded to the tone number corresponding to their original number, but this may vary as follows depending on the circumstances within the sampler's memory.

- When tone numbers of the patch being loaded are also in use on the sampler :

It is loaded under tone numbers not being used on the sampler, and at the same time the tone numbers assigned within the patch are revised. Thus, there is no need for redoing split settings.

- When the unused number of tones in the sampler's memory are not enough to cover the amount used by the patch being loaded :

"Memory Full" is displayed, and the load is aborted.

- When the space limitations of the sampler's Wave banks prevent all the tone Wave data from being loaded :

Loading takes place from tone number 11. When Wave bank A becomes full, it moves to Wave bank B. If it doesn't fit into bank B, "Memory Full" is displayed, and the load is terminated. It then displays a list of the tones that couldn't be loaded. When you wish to load these remaining tones, delete unnecessary tones in the same block, and use the "Load Tone" function to load them one at a time.

- When loading two patches from the same disk :

When the same tone is used by 2 patches, it is loaded each time. Thus, the same tone will be loaded twice.

- When loading sub-tones :

When loading sub-tones, and in the same patch the original tone is used as well, it automatically becomes a sub-tone.

When the original tone is not being used in the same patch, automatically the original tone is loaded as well, and it becomes a sub-tone.

\* All tones will be loaded to the block identical to the block of the destination patch number.

### Loading patches from floppy disk to the sampler

Step 1 In the DISK mode, select the "FD Load P" menu.

Step 2 Set the following parameters :

●FD P #

Select the number of the patch you wish to load.

●Int P # (Del #)

Select the destination patch number on the S-550.

#### Checking the Tone List

Open the Command window and give the command "FD Load T.List" to check usage status for the tones of the source patch and the destination block.

[FD] Tones used by the patch selected in "FD P #" are displayed. Those indicated with "Org" are original tones used in the patch, and those with "Sub" are sub-tones used in the patch. Those indicated with "---" are tones not used by that patch.

[I] Tones in the S - 550 are displayed. Those tones with the "\*\*\*" indicator can be loaded, those with "---" cannot be loaded.

Step 3 Open the Command window, and execute the "FD Load Patch" command.

When loading has finished, "Complete" is displayed.

When all of the tones could not be loaded, it displays a list of the tones that weren't. When you wish to load these remaining tones, delete unnecessary tones in the same block on the sampler, and use the "Load Tone" function to load them one at a time.

\* For information on loading patches from the CD-5, see page 29.



## 8. Deleting patches

If you wish, patches within the S-550 can be deleted.

As the result of this procedure, the patch parameters for that patch are initialized, and the original tones and sub-tones used by the patch are deleted.

\* This function is available with either "CD Load P", "HD Load P", or "FD Load P."

Step 1 Select "CD Load P" from the UTIL mode ; or from the DISK mode, either "HD Load P" or "FD Load P."

Step 2 Make settings for the following parameters :

● Int P # (Del #)

Select the patch in the S-550 you wish to delete.

● Used Tone Only

When the patch you wish to delete contains original tones or sub-tones used by another patch, when you delete the patch you will suffer the loss of sounds. To prevent this, set this parameter at "On" and original tones and sub-tones used elsewhere will be preserved within the sampler.

If you move the mouse cursor to "Int P # (Del #)", a listing of the patches within the S-550 will be displayed.

Step 3 Open the Command window and give the command "\* Delete Patch."

When through, "Complete" will be displayed.

## 9. FD Backup

The CD-5 System cannot be put onto a sound data disk.

For this reason, any sound disks created will be as illustrated below, and not contain the system.

Please remember that such disks cannot be used to boot the S-550.

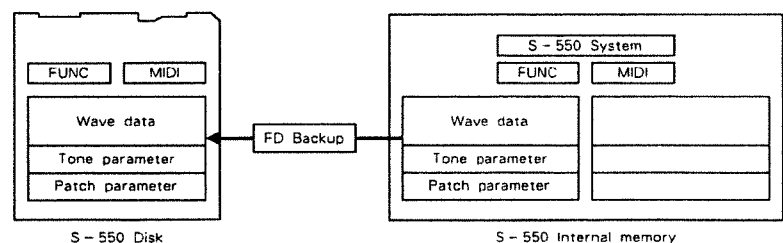

## 4 Use as a CD player

The CD-5 can also be used as an audio CD player.

### Connection





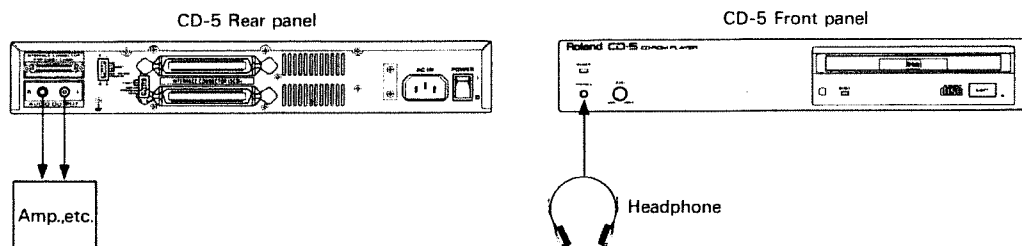



Connect audio cables from the output jacks (stereo output) on the rear panel to the CD or AUX inputs of an amplifier or other equipment.

\* Since the volume cannot be controlled on the CD-5, carry out such control on the amplifier side.





Headphones can be used only when in use as a CD player.  
Adjust the volume with the headphones level knob on the front panel.

- Step 1 From the UTIL mode, select the "CD-Player" menu.
- Step 2 Move the mouse cursor, and using the right and left buttons, control functions such as start, stop, etc.

	Start/Stop
	Pause/Restart
	Reverse
	Fast Forward
	Skip to previous track (song start)
	Skip to next track (song start)
	Eject CD caddy
	(See next page)

These two appear in the display when "\*" is selected :

	Jump to cue point
	Shifts cue point 0.1 second forward or backward

In addition, track information is displayed.

<b>Track #</b>	Shows number of track selected
<b>Index #</b>	When there is an index, shows its number
<b>A-time</b>	Displays elapsed time from start of first track
<b>P-time</b>	Displays elapsed time from start of current track

\* During playback, the CD-5's busy indicator will be lit.



## 5 Sampling from the CD - 5

The S-550 can be used to directly sample from the CD-5, while it is operated as a CD player as explained on the previous page.

Connect either of the CD-5's audio output jacks to an input jack on the S-550.

### Setting the Cue Point

The point from which sampling will start on the CD should be set beforehand. This point is referred to as the "Cue point."

- Step 1 From the UTIL mode, select the "CD Player" menu.
- Step 2 Move the cursor over  and start play of the CD.
- Step 3 Move the cursor to  and at the moment you hear the start of the sound you wish to sample, press either the left or right mouse button.

Where you pressed the button then becomes the cue point.

\* The sampling cue point can later be adjusted, so it is not that critical how precise you were.

The display will show the time from the start of the first track on the CD to your cue point.

- Step 4 While playing the CD, move the cursor to  and press either button on the mouse.

The audio CD will playback beginning at your cue point.

- Step 5 When the sound doesn't begin where you want for sampling, move the cursor to  and use right and left mouse buttons to shift the cue point.

\* The cue point can be set in steps of 0.1 second. Thus, an error of up to  $\pm 0.1$  second can occur, so it is wise to set cue points slightly earlier.

Repeat steps 4 and 5 to get the cue point where you want it.

## Making samples

Perform the following to sample from the cue point you have set.

Step 1 In the UTIL mode, select the **"Sampling"** menu.

Step 2 Set the **"CD Cue Switch"** parameter at **"On."**

The CD will play for about 1 second longer than the amount of time in the actual sample. The cue point will be displayed.

\* When no cue point has been set, **"On"** cannot be obtained.  
Be aware that after setting a cue point, if you carry out a range of other operations, the cue point may at times be cancelled.

Step 3 Switch back and forth between On and Off as settings for **"CD Cue Switch"** to play the audio CD, and adjust the level using the S-550's recording level knob.

\* Set the Line/MIC switch at Line.

\* Settings for **"Threshold"** and **"Pre-trigger"** should be made if necessary.

Step 4 Set **"CD Cue Switch"** to On. Open the Command window and give the **"Auto"** command.

\* If **"CD Cue Switch"** is set to Off, sampling from the CD Player cannot be accomplished.

\* Commands other than **"Auto"** will not work.

**"Ready"**, **"Start"** and **"Working"** will be displayed, and when finished, **"Complete"** is displayed.

While in operation, the CD-5's Busy indicator will be lit, and sounds being sampled can be heard through the output.

Step 5 Play a keyboard to try the sampled sounds.

The cue point set in the **"CD-Player"** screen accepts settings in steps of 0.1 second. Thus, an error of up to  $\pm 0.1$  second can occur. At times the sampling may not occur from the point you thought it would. In such cases, open the Command window and try again.

## 6 Backing up the System Disk

Carry out the following to make a copy of the CD-5 System Disk for backup on a different disk.

\* This procedure needs to have the System Program and Utilities all be moved once into the S-550, and then be saved to floppy disk. As a result, anything contained in memory in the S-550 will be lost. Therefore, if you wish to retain any sound data contained in internal memory, it must be saved onto disk beforehand.

- Step 1      Insert the CD-5 System Disk into the disk drive.
- Step 2      From the UTIL mode, select the "SYS. Backup" menu.
- Step 3      The following parameters can be changed and saved if desired :
- S/Load I ← Area
  - S/Load II ← Area
  - S/Load (P.CHG)
  - S/Controller
- For explanation of these parameters, see page 24, "Startup settings."
- Step 4      Open the Command window and execute the "SYS. Backup" command.
- "Now Loading" is displayed, and the contents of the CD-5 System Disk are loaded into the sampler. When loading has finished, the message "Change disk" appears.
- Step 5      Remove the CD-5 System Disk from the drive.
- Step 6      Take a floppy disk to be used as the backup, make sure its protect tab is at the WRITE position, and insert it into the drive.
- In the message line you should see "Formatting" .... "Now Saving."  
When successfully saved, "Complete" is displayed.
- Step 7      Take the disk out of the drive and move its protect tab to the PROTECT position.

## ■ TROUBLESHOOTING

When you are sure that all your procedures and settings have been made correctly, and still you repeatedly have problems, contact your nearest Roland Service Center.

### 1. SCSI Check

#### When booted up

Always use the System Disk supplied with the CD-5. The CD-5 System automatically performs a SCSI check when booting.

● **Stopped partway through boot.**

☐ Turn power off, then on again to the S-550, CD-5, and hard disk.

● **While booting, "I/F Error" is displayed in the message line.**

☐ Check to make sure the CD-5 and hard disk are connected properly.

☐ Check to make sure the internal connection between S-550 and HD5-IF was correctly made.

☐ When connections are not at fault, and still "I/F Error" is repeatedly displayed, the HD5-IF itself should be suspected. Contact your nearest Roland Service Center.

● **When booting, at SCSI Check on the message line, "C" (CD-5) or "H" (hard disk) fails to be displayed.**

☐ Check to make sure power to CD-5 or hard disk is on. In such cases, if you then turn power on, perform "SCSI Check" by giving the command from the "Setup" menu in the DISK mode.

☐ Make sure that CD-5 and hard disks are connected properly.

☐ Make sure you don't have the same ID number set for both CD-5 and hard disk.

☐ When connections are not at fault, and still "I/F Error" is repeatedly displayed, the CD-5 or HD5-IF should be suspected of malfunction. Contact your nearest Roland Service Center.

\* At SCSI Check on the message line, ID numbers are displayed from the left, starting at 0. C indicates CD-5, H, a hard disk. \* means nothing is connected.

● **The CD-5 Busy indicator stays on continually.**

☐ Turn power to the CD-5 off, then on again.

● **"Unformatted" is displayed during boot-up.**

☐ The hard disk hasn't been formatted. You need to format it first.

## SCSI Check Command

When you give the "SCSI Check" command (by opening the Command window in the DISK mode's "Setup" menu), all connections and ID numbers can be checked.

### ● When NG is displayed as the result of "I/F check."

- ☞ Check to make sure that the internal connections between HD5-IF and the S-550 were made properly.
- ☞ When connections are not at fault, and still "I/F Error" is repeatedly displayed, the HD5-IF itself should be suspected. Contact your nearest Roland Service Center.

## While formatting a hard disk

Giving the "HD Format" command (by opening the Command window in the DISK mode's "Setup" menu), formats a hard disk.





### ● "HD Connection Error" is displayed.

- ☞ Use the "SCSI Check" command to determine whether or not the HD5-IF and hard disk are properly connected.
- ☞ Check to make sure power to the hard disk is on.

## During CD Player / Sampling from CD operations

With audio CDs, scratches and dirt can cause irregular tracking and other reproduction problems. Keep your discs clean using a commercially available cleaner specialized for cleaning CDs.

### ● In CD play, you are unable to hear play of a song (time display doesn't move, CD doesn't play) after using either (reverse), (fast-forward), (skip-to-previous), or (skip-to-next).

- ☞ Try the  (reverse),  (fast-forward),  (skip-to-previous), or  (skip-to-next) operation once again.

### ● During sampling, even with "CD Cue Switch" at "On", the Busy indicator on the CD-5 remains lit, it doesn't play, and the S-550 no longer responds properly.

- ☞ Turn off power to the CD-5, wait for 12-13 seconds, then turn it on again.

In the message line "UNIT ATTENTION" will be displayed, and the S-550 will become operable again. Once again, select the "CD Player" menu, and reset the cue point.

Should the S-550 still remain inoperable, turn it off and reboot.

## 2. ERROR MESSAGES

### ● I/F Error

Either the internal connector between HD5-IF and S-550 is improperly connected, or there is a malfunction in the HD5-IF.

### ● Unformatted

The hard disk is not in a state where it may be used with the S-550. Perform Setup.

### ● HD Connection Error

Either the hard disk is not connected, or its power is off. Perform SCSI Check.

### ● SCSI Error

Due to a malfunctioning HD5-IF, or other reasons, the data exchange with CD-5 or hard disk is not reliable. Perform SCSI Check.

### ● CD Player Disconnect

Either the CD-5 is not connected, or its power is off. Perform SCSI Check.

### ● Caddy not inserted

There is no caddy inserted. Insert the caddy, containing CD-ROM or audio CD.

### ● NOT READY

Due to reasons such as the caddy is not inserted properly, the CD-5 is not in a state where it may operate. Remove caddy and turn it to on again.

### ● MEDIUM ERROR

Due to scratches or dirt on the CD disc, data could not be read. Use a commercially available specialized cleaner to clean disc.

### ● HARDWARE ERROR

The CD-5 hardware itself is experiencing malfunction. Contact your nearest Roland Service Center.

### ● UNIT ATTENTION

The CD-5 has been reset, such as after power has been lost.



## MIDI Implementation Chart

Function...		Transmitted	Recognized	Remarks
Basic Channel	Default	×	1-16 *4	*2
	Changed	×	1-16 *4	
Mode	Default	×	3	
	Messages	×	×	
	Altered	*****	×	
Note Number	True Voice	×	12-120	
		*****	12-120	
Velocity	Note ON	×	*1	V=1-127
	Note OFF	×	×	
After Touch	Key's	×	×	
	Ch's	×	*1	
Pitch Bender		×	*1	
Control Change	1	×	*1	Modulation Volume Hold 1
	7	×	*1	
	64	×	*1	
	100, 101 6, 38		*1	RPC LSB, MSB DATA Entry LSB, MSB Number-0 Pitch Bend Sensitivity
Prog Change	True #	*****	*1 0-127 0-127	*3
System Exclusive		*1	*1	
System Common	Song Pos	×	×	
	Song scl	×	×	
	Tune	×	×	
System Real Time	Clock	×	×	
	Commands	×	×	
Aux Message	Local ON/OFF	×	×	
	All Notes OFF	×	○ (123-127)	
	Active Sense	×	×	
	Reset	×	×	
Notes		*1 Can be set to ○ or × manually, and memorized by disk. *2 Memorized by disk. *3 Patch numbers for each program change number can be set freely. *4 MIDI Channel of each voice group can be set in Multi Channel Mode.		

Mode 1 : OMNI ON, POLY  
Mode 3 : OMNI OFF, POLY

Mode 2 : OMNI ON, MONO  
Mode 4 : OMNI OFF, MONO

○ : Yes  
× : No

## ■ SPECIFICATIONS

### CD - 5 : CD - ROM Player

#### ■ Disc

Applicable disc : CD-ROM disc  
CD-Audio disc

Disc diameter : 12cm

Rotational speed (Depends on the disc)

Innermost track :  
530 rpm at CLV = 1.4 meter/sec  
Outermost track :  
200 rpm at CLV = 1.2 meter/sec

#### ■ Drive performance

Data transfer rate  
Sustained rate : 150 kilobyte/sec

Access time  
Full stroke : 0.8 sec (typical)  
Average (1/3 stroke) : 0.5 sec (typical)

#### ■ Reliability

Read error rate (includes retry)  
L-EC on : 1 Block/10<sup>12</sup> bits  
L-EC off : 1 Block/10<sup>9</sup> bits  
Preventive maintenance : Not required

#### ■ Audio

Output level  
Line out : 2.0V at 50k $\Omega$   
Headphone : 0.45V at 32 $\Omega$   
(at maximum volume)

#### ■ Environmental condition

Operating  
Temperature : 5 to 45°C  
Humidity : 15 to 90%  
Absolute humidity : 30 grams/m<sup>3</sup>  
(maximum wet bulb temperature is 29°C)  
noncondensing

Non-operating/Transportation  
Temperature : - 30 to 55°C  
Humidity : 15 to 90%  
Atmosphere : noncondensing

#### Vibration

Operating : 0.2 G<sub>o-p</sub> at 5 to 300Hz  
Non-operating : 2 G<sub>o-p</sub> at 5 to 300 Hz  
Transportation : 0.015 G<sup>2</sup>/Hz at 5 to 50Hz  
(with standard package)

#### Shock

Operating : 0.4 G<sub>o-p</sub> at 11ms half sine wave  
Non-operating : 40 G<sub>o-p</sub> at 11ms half sine  
wave  
Transportation 76 cm drop  
(with standard package)

#### ■ Laser use

Type : Semiconductor laser GaAlAs  
Wave length : 780 nm  
Output power : 0.6 mW  
Beam divergence : 53.4° ± 1.5°

#### ■ Front Panel

Power Indicator  
Caddy Slot  
Eject Button  
Manual Eject  
Busy Indicator  
Headphone Jack  
Headphone Level Knob

#### ■ Rear Panel

Power Switch  
AC IN Connector  
Interface Connectors (SCSI)  
DIP Switches  
Audio Output Jacks  
Ground Terminal

#### ■ Dimensions

355 (W) x 337 (D) x 61 (H) mm

#### ■ Weight

5.6kg/ 12 lb, 5 oz

#### ■ Power Consumption

120V : 0.31A  
220V - 240V : 0.2A

■ Accessories

- Caddy
- CD-ROM (L-CD1)
- CD-5 System Disk x 2
- ID Number Label
- AC Cord
- CD-5 Interface Cable (25 pin - 50 pin)
- Owner's Manual
- List of Sounds on L-CD1

■ Options

- HD5-IF

■ Diagram of pin connections

Pin No.	Signal	Pin connections
1-12, 14-25, 35-37, 39,40,42	GND	<p>25 ..... 1</p> <p>50 ..... 26</p>
13	NC	
26	DB0	
27	DB1	
28	DB2	
29	DB3	
30	DB4	
31	DB5	
32	DB6	
33	DB7	
34	DBP	
38	TERMPWR	
41	ATN	
43	BSY	
44	ACK	
45	RST	
46	MSG	
47	SEL	
48	C/D	
49	REQ	
50	T/O	

 Roland®

79514299

UPC 79514299



18981

505

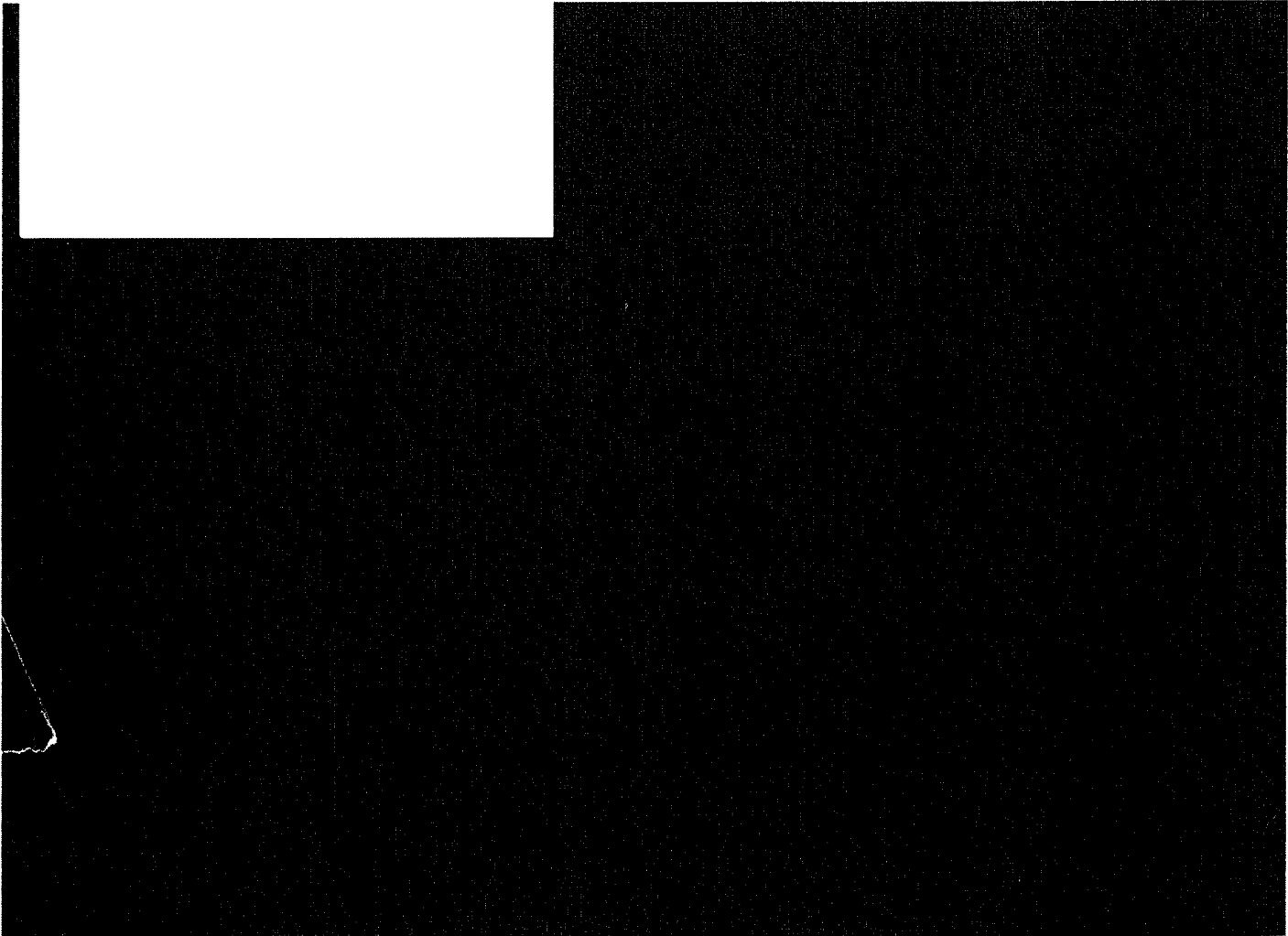

 Roland