

Roland

SAMPLER SYSTEM SOFTWARE
S-760 Ver.2

POWER SAMPLING EXPANSION
OP-760-1

OWNER'S MANUAL

Attention all S-760 users

Depending on the version of S-760 system software and whether or not the Power Sampling Expansion (OP-760-1) has been installed, the available functions and operation procedures will be different. The way in which you read the manuals will depend on your setup.

With the S-760 (Ver.1), two manuals are included: "Basic Operation" and "Advanced Operation".

With the S-760 Ver.2, the above two manuals and an additional manual titled "S-760 Ver.2/OP-760-1" are included.

With the OP-760-1, one manual is included: "S-760 Ver.2/OP-760-1" .

These manuals contain the following contents.

[Basic Operation]

This manual explains basic ideas and operation of the S-760 Ver.1. It explains how to operate the unit using its LCD display and the front panel buttons.

[Advanced Operation]

This manual explains more advanced uses, such as how to edit S-760 Ver.1 sounds. It explains how to operate the unit using its LCD display and the front panel buttons.

[S-760 Ver.2 / OP-760-1]

This manual explains the functions and parameters which were added/modified in S-760 System Software Ver.2, and the functions and operation of the OP-760-1 which is available as an option for the S-760. Refer to this manual for how to operate the unit using a CRT display and mouse.

Caution!

The functions of the OP-760-1 are available only when the S-760 is started up using S-760 System Software Ver.2. If you start up using Ver.1, you will not be able to use the OP-760-1 even if it is installed.

Note the following points applicable to your system, and read the appropriate sections of each manual.

■ If you upgraded from Ver.1 to Ver.2

Start up the S-760 using the Ver.2 system disk.

You will be able to use the functions of S-760 System Software Ver.2, but the functions of the OP-760-1 will not be available.

■ If you previously owned an S-760 (Ver.1) and newly purchased an OP-760-1

Start up the S-760 using the system disk (Ver.2) included with the OP-760-1. You will be able to use all the functions of S-760 System Software Ver.2 and the OP-760-1. Refer to "S-760 Ver.2/OP-760-1".

■ If you purchased an S-760 (Ver.1) and an OP-760-1 together

Start up the S-760 using the system disk (Ver.2) included with the OP-760-1. You will be able to use all the functions of S-760 System Software Ver.2 and the OP-760-1. Refer to "Basic Operation" and "S-760 Ver.2/OP-760-1." As necessary, refer to "Advanced Operation."

■ If you purchased an S-760 Ver.2 by itself

Refer to "Basic Operation" and "S-760 Ver.2/OP-760-1." As necessary, refer to "Advanced Operation." You will be able to use the functions of S-760 System Software Ver.2, but not the functions of the OP-760-1.

■ If you purchased an S-760 Ver.2 and an OP-760-1 together

Refer to "Basic Operation" and "S-760 Ver.2/OP-760-1." As necessary, refer to "Advanced Operation." The system disk for the S-760 Ver.2 and the system disk (Ver.2) included with the OP-760-1 are identical. You may use either of them to start up the S-760. You will be able to use all the functions of the S-760 System Software Ver.2 and the OP-760-1.

■ If you previously owned an S-760 Ver.2 and newly purchased an OP-760-1

Refer to "S-760 Ver.2/OP-760-1." The system disk for the S-760 Ver.2 and the system disk (Ver.2) included with the OP-760-1 are identical. You may use either of them to start up the S-760. You will be able to use all the functions of the S-760 System Software Ver.2 and the OP-760-1.

Please be aware of the following points as well.

■ Start up / shut down procedure

Start up using the system disk (Ver.2). To start up/shut down, refer to "Starting up and shutting down" (Basic Operation p.1-6). If you wish to start up from a hard disk rather than from a floppy disk, refer to "Starting up from a hard disk" (Basic Operation p.5-1).

Ver.1 users should refer to the following item "How to upgrade from Ver.1 to Ver.2."

If you have installed an OP-760-1 and wish to use a CRT and mouse, make connections before startup (Ver.2 p.2-3). For details on how to switch to CRT display and mouse operation, refer to "Operation using the CRT display and mouse / RC-100" (Ver.2 p.3-1).

■ Backing up the system disk

The system disk (Ver.2) is very important, and you should make a backup and keep the original disk in a safe place. For details refer to "Backing up the System Disk" (Basic Operation p.1-8).

■ Attention S-760 Ver.1 users

● How to upgrade from Ver.1 to Ver.2

If you start up using the Ver.2 system disk, you will be able to use the functions of S-760 System Software Ver.2. However the system program and system parameters are always saved together. If when you were using the Ver.1 system disk you modified the system parameters from their factory settings and then saved them, the system parameters will return to their factory settings when you start up using the Ver.2 system disk.

For details on upgrading, refer to "Upgrading to a new version of the system" (Advanced Operation p.6-6). There are two types of system parameters, so also refer to "Loading/Saving the system" (Basic Operation p.8-7).

Caution!

The display screen structure differs between Ver.1 and Ver.2. For this reason, screen mark lists saved in Ver.1 (system parameter) cannot be used in Ver.2. Even if you follow the procedure in "Upgrading to a new version of the system" to load system dumped data, the mark list data will be unrecognized by Ver.2. If you wish to keep the mark list data you saved, you will have to write it down and re-input it after upgrading. Other data which is system dumped (the quick load list, the volume ID list, the user set template list) can be used by Ver.2

● Sound data compatibility between Ver.1 and Ver.2

Some sound parameters have been added/modified in Ver.2, but all sounds created on the S-760 Ver.1 can be used just as they are in Ver.2. For details refer to "Functions added/modified in Ver.2" (Ver.2 p.1-1).

Please be aware that the sections "Sound data compatibility" (Advanced Operation p.2-1) and "PARAMETER LISTS" (Advanced Operation p.7-16) were written for Ver.1.

How to install the OP-760-1P

The OP-760-1P includes the following components.

*OP-760-1P MAIN Board	(70349156)	1
*OP-760-1P VIDEO Board	(*****)	1
*SYS-S760-7 Ver.2.0	(00124012)	1
*Mouse MU-1	(00236156)	1
*OP-760-1P EXP Cover	(00120423)	1
*OP-760-1P Instruction Manual	(00125878)	1
Screws *Boss Nuts 22mm	(22155546)	4
*3X6 STB Cm		4
*3X8 PTB BC		1

Installation Procedure

1. Turn the power off and disconnect the power cord from the AC inlet.
2. Remove the TOP cover and EXP cover of S-760. Keep the screws (3X6 BTB CB) for the EXP cover, as they will be used later on.
3. Referring to the figure, use four boss nuts to secure the OP-760-1P MAIN Board in place.
4. Connect the wiring cables CN1 and CN2 on the VIDEO Board to both CN2 and CN3 of OP-760-1P MAIN Board, and attach the VIDEO Board onto the OP-760-1P Main Board using four pieces of 3X6 STB Cm.
5. Remove two screws (2.6X5) securing the EXT CTRL connector on the OP-760-1P MAIN Board, then tighten them along with OP-760-1P EXP cover. The EXT cover should be fastened using the two screws removed in step 2. Screw into the middle of the four pin jacks using a 3X8 PTB CB.
6. To use OP-760-1P and S-760 together, you will need to use the S-760 system program ROMs Ver. 1.10 or later instead of previous ROMs.
Also to boot up S-760, use S-760 System Software Ver.2.10 or later.
7. Reattach the TOP cover.
8. After OP-760-1P installation was finished, set the [5. TV System] parameter (NTSC or PAL) to TV form in places where S-760 will be used.
Turn the power on while pressing MODE, the Setup Menu display will appear. The MODE indicator will blink. Select the [5. TV System] parameter by cursor button, and use Value knob, or S1/DEC(Dec) and S2/INC(Inc) to select NTSC or PAL.
* The [TV System] parameter is saved in the system backup memory inside the S-760.
When you finish making setting, press EXIT. The setting will be saved into the S-760 system backup memory, and the S-760 will start up as usual.

After finished [TV System] parameter setting has been completed, check each of the following functions of OP-760-1P.

- Startup of the SYS-S760-7
- Operation of the MOUSE
- Output of the S-VIDEO connector
- Output of the DIGITAL RGB connector
- Output of the VIDEO connector
- D.in and D.out functions

(PARTS)

No.	PART No.	PARTS NAME
①	70349156	OP-760-1P MAIN Board
②	*****	OP-760-1P VIDEO Board
③	00120423	OP-760-1P EXP Cover

(SCREW)

Ⓐ	*****	M3X6mm S-Tight Bind Cm
Ⓑ	*****	Buss nut M3/M3 L22
Ⓒ	*****	M3X6mm B-Tight Bind Bc
Ⓓ	*****	M3X8mm P-Tight Bind Bc
Ⓔ	*****	M2.6X5mm S-Tight Bind

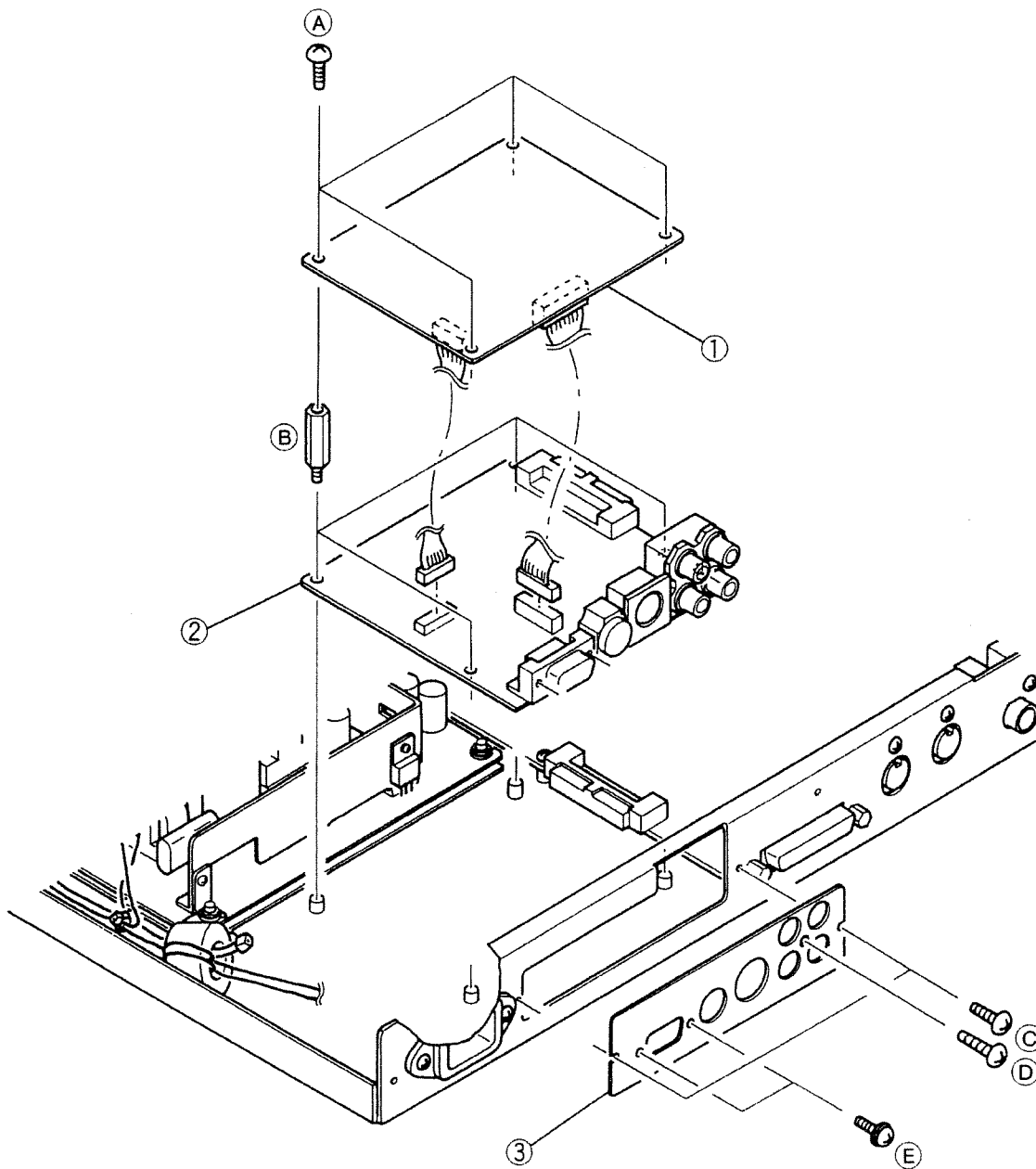

Important notes concerning use of a CRT display

When using a CRT display in combination with the unit, please observe the following points.

*** If an OP-760-1P Power Sampling Expansion is installed, be sure to use system disk version 2.10 or later. The unit will not operate correctly with a system disk earlier than version 2.10.**

■ When using a CRT display, a home television with a video input connector, or a home television with an S-video connector

CRT displays, home televisions with video input connectors, and home televisions with S-video connectors are designed to handle a specific video format, such as NTSC or PAL.

*** NTSC is the video format used in the United States and Japan. PAL is the video format used mainly in Europe, etc.**

With the OP-760-1P Power Sampling Expansion installed, the Setup menu screen will provide an additional parameter, TV System. Set this parameter (NTSC, PAL) to the video format (NTSC or PAL) appropriate for your CRT.

If the TV System setting is not appropriate for your CRT display, the screen display will not be correct.

■ When using a digital RGB CRT

With the OP-760-1P Power Sampling Expansion installed, the Setup menu screen will provide an additional parameter, TV System. If you are using a 200 line digital RGB CRT display, set the TV System parameter to NTSC. If this parameter is set to PAL, the screen may not be correct on some RGB CRT displays.

■ How to set the TV System parameter

1. While pressing MODE, turn the power on. The Setup menu screen will appear (S-760 Basic Operation p. 6-2).

*** The MODE indicator will start blinking.**

2. Use the cursor buttons to select 5. TV System, and use the value knob or the S1/DEC (Dec) and S2/INC (Inc) buttons to set the parameter value.

3. When you finish setting the value, press EXIT. The system will start up, and the Perform Play 1 screen will appear.

*** The TV System parameter is saved in the System Backup Memory inside the S-760. The parameter value is saved automatically when you press EXIT.**

Caution!!

TV System settings affect all the video outputs.

For example, if the TV System parameter is set to NTSC, the video signals from the Digital RGB connector, VIDEO connector, and S-VIDEO connector will all be in NTSC format.

CRTディスプレイを使用する場合のご注意

CRTディスプレイを使用して操作する場合、以下の注意事項があります。

- * パワー・サンプリング・エクステンション OP-760-1Pを装着した場合、必ずVer. 2.10以降のシステム・ディスクを使用して下さい。Ver. 2.10より前のシステム・ディスクを使用すると、正常に動作しません。

■CRTディスプレイ、ビデオ入力端子付の家庭用テレビ、S端子付の家庭用テレビの場合

CRTディスプレイ、ビデオ入力端子付の家庭用テレビ、S端子付の家庭用テレビには、NTSC方式やPAL方式などがあります。

- * NTSC方式とはアメリカや日本で採用されている規格です。PAL方式とは主にヨーロッパなどで採用されている規格です。

パワー・サンプリング・エクステンション OP-760-1Pを装着した場合、セットアップ・メニュー画面に、TV Systemというパラメーターが追加されます。このパラメーターの設定（NTSC、PAL）を、使用するCRTディスプレイの規格（NTSCまたはPAL）と同じに設定してください。

TV Systemの設定がCRTディスプレイの規格と異なる場合、画面を正しく表示できません。

■デジタルRGB CRTディスプレイの場合

パワー・サンプリング・エクステンション OP-760-1Pを装着した場合、セットアップ・メニュー画面に、TV Systemというパラメーターが追加されます。200ラインのデジタルRGB CRTディスプレイを使用する場合、TV SystemをNTSCに設定してください。PALに設定した場合、お使いのRGB CRTディスプレイによっては、画面を正しく表示できないことがあります。

■TV Systemの設定のしかた

1. MODEを押しながら電源を投入します。セットアップ・メニュー画面が開きます（S-760基本編P.6-2）。

- * MODEのインジケーターが点滅します。

2. カーソル・ボタンで、5. TV Systemを選択し、バリューつまみ、またはS1/DEC(Dec)とS2/INC(Inc)で設定します。

3. 設定が終了したらEXITを押します。起動後、Perform Play 1画面が開きます。

- * TV Systemは、S-760本体内のシステム・バックアップ・メモリーに保存されているパラメーターです。EXITを押すことによって、自動的にセーブされます。

ご注意!!

TV Systemの設定は、すべての映像出力に関係します。

たとえば、TV SystemをNTSCに設定した場合、Digital RGBコネクター、VIDEOコネクター、S-VIDEOコネクターのすべての映像出力が、NTSC方式に対応したのになります。

The range of Device ID Number settings has changed

The range of SP-700 and S-760 Device ID Number settings has changed as follows. This change has been made so that the Device ID Number value can begin from 1 just as MIDI channels do, for greater understandability.

Device ID Number before change	Device ID Number after change	The actual MIDI Exclusive data that indicates the Device ID Number
[0]	[1]	00H
[1]	[2]	01H
[2]	[3]	02H
:	:	:
[31]	[32]	1FH

● For the SP-700

The change has been made starting with SP-700 system version 1.05. The version number of your SP-700 system is displayed in the LCD when the power is turned on.

● For the S-760

The change has been made starting with S-760 system version 2.01. The version number of your S-760 system is displayed in the LCD or CRT when the power is turned on.

■ Cautions related to the change in setting range

The range of Device ID Number settings will differ depending on the SP-700 or S-760 system version. If, using an earlier SP-700 or S-760 system (i.e., a system version earlier than the change) you set the Device ID Number and perform the following operations, be aware of possible problems with MIDI Exclusive data transmission.

1. When you have used the Volume Dump function, Sample Dump function, or System Dump function (SP-700 only) to save Volume or System data on a sequencer as MIDI Exclusive data.
2. When you have used a computer to save sound data on a hard disk etc. as MIDI Exclusive data.

In the above two cases, if you want data saved by an earlier system version to be received by a SP-700 or S-760 with a later system version, you must use the following procedure.

As the Device ID Number for reception, set a value equal to 1 greater than the Device ID Number used by the earlier SP-700 or S-760 when saving the data.

For example if you have used Device ID Number [3] when saving the data, you must reset the SP-700 or S-760 Device ID Number to [4] before receiving the MIDI Exclusive data.

** MIDI Exclusive data saved using a SP-700 or S-760 system of or later than the version numbers listed above (i.e., after the change in setting range was made) can be received using the same Device ID Number as used when saving the data.*

** For details on how to set the Device ID Number, refer to the manual for your device. The manual gives the range of Device ID Number settings as [0]-[31], so please read [0] as [1], and [31] as [32].*

SP-700: P.Sys-16, P.Sys-25, etc.

S-760: Advanced Operation p.3-97, Advanced Operation p.3-99, etc.

New parameter added to the CD Player function

From S-760 System Software Ver 2.17, the following parameter has been added to the CD Player function.

This parameter make it possible to use the CD Player function even with CD-ROM drives that Roland has not checked for compatibility.

System SCSI display

CDP Driver Type (CD Player Driver Type) **System 2** [Off, 1-7]

Several drivers for CD-ROM drives are registered in the S-760, and a check is made automatically to see whether a driver exists for the CD-ROM drive that is connected. This means that if a driver for that CD-ROM drive has not been registered, a message of "Not Supported" appears, and further operation is not possible.

Thus, S-760 System Software 2.17 adds drivers for seven types of CD player. By selecting a driver appropriate for a CD-ROM drive which has not been tested for compatibility, you can use the CD Player function even with a CD-ROM drive that does not appear in the list "SCSI devices usable with the S-760."

○ Check the S-760 system version

When the power is turned on, the LCD display or CRT display will indicate the version of your S-760 system. Please use Ver.2.17

● Check whether the CD Player function is usable

LCD procedure

1. Insert an audio CD into the CD-ROM drive.
2. Press MODE. The Mode menu will appear.
3. Press F1 (Performance). The Performance Mode display will appear.
4. Press VALUE/MENU (PUSH). The Performance Menu will appear.
5. Move the cursor to 1:Performance Play, and press S1/DEC (Open). The Performance Play display will appear.
6. Press COMMAND. The Performance Command Menu will appear.
7. Move the cursor to 8:CD Player, and press S1/DEC (Select). The CD Player display will appear.
8. Press S1/DEC (List). A list of the SCSI devices connected to the S-760 will appear.
9. Move the cursor to the desired CD-ROM drive, and press S1/DEC (Sel). The CD-ROM drive will be selected as the current drive.

At this time, if the song times appear in the display, the CD Player function supports this CD-ROM drive. You may use the drive without further steps.

If the LCD displays "Not Supported," the CD Player function does not support this CD-ROM drive. In order to use the CD Player function with this CD-ROM drive, perform the procedure given in the section below.

CRT procedure

1. Insert an audio CD into the CD-ROM drive.
2. From the Perform MENU, select Perform Play. The Performance Play display will appear.
3. From the Com MENU, select CD Player. The CD Player display will appear.
4. Click on " CD-ROM " or " ??? ". A list of the SCSI devices connected to the S-760 will appear.
5. Click the desired CD-ROM drive. The CD-ROM drive will be selected as the current drive.
At this time, if the CRT displays the song times, the CD Player function supports this CD-ROM drive. You may use the drive without further steps.
If the CRT displays "Not Supported," the CD Player function does not support this CD-ROM drive. In order to use the CD Player function with this CD-ROM drive, perform the procedure given in the section below.

● Enabling the CD Player function

- * While you are performing the following procedure, it is possible that the S-760 or the CD-ROM drive may malfunction. If a malfunction occurs, you will not be able to continue the procedure. Turn off the power of both the S-760 and the CD-ROM drive, and then turn the power on once again. Also, save any unsaved data before starting this procedure, so that you will be able to turn off the S-760 power at any time.

LCD procedure

1. Press MODE. The Mode Menu will appear.
2. Press F6 (System). The System Mode display will appear.
3. Press VALUE/MENU (PUSH). The System Menu display will appear.
4. Move the cursor to 2:SCSI, and press S1/DEC (Open). The System SCSI display will appear.
5. Specify the CD Player Drive Type. Move the cursor to CDP Drive Type, and use VALUE/MENU (PUSH) to select 1.
6. Open the Performance Play display.
Press MODE.
Press F1 (Performance).
Press VALUE/MENU (PUSH).
Move the cursor to 1:Performance Play, and press S1/DEC (Open).
7. Open the CD Player display.
Press COMMAND.
Move the cursor to 8:CD Player, and press S1/DEC (Select).
8. Check the following items.
Are Track, A-Time, and P-Time displayed?
Is F2 (Stop) displayed?
When you press F2, does the display change to (Play) and the CD playback begin?
If during CD playback you press [F2], does the display change to (Stop) and the CD playback stop?
When you press F3 (>>|), does the CD jump to the beginning of the next song?
When you press F1 (|<<), does the CD jump to the beginning of the previous song?
When you press F4 (1Trk), does the CD jump to the beginning of the first song?

9. If there is a problem with even one of the above items, change the CDP Driver Type setting and try again. Repeat steps 1 to 8. If you find a setting number that works correctly, use that number thereafter.

* In some cases you may try all settings without finding one that works. In this case, the S-760 System Software Ver.2.17 is not able to use the CD Player function with your CD-ROM drive. Set the CDP Driver Type to Off.

CRT procedure

1. From the System MENU, select SCSI. The System SCSI display will appear.
2. Specify the CD Player Driver Type. Move the cursor to CDP Driver Type, and click the mouse to select 1.
3. From the Perform MENU, select Perform Play. The Performance Play display will appear.
4. From the Com MENU, select CD Player. The CD Player display will appear.
5. Check the following items.
Are Track, A-Time, and P-Time displayed?
Is F2 (Stop) displayed?
When you press F2, does the display change to (Play) and the CD playback begin?
If during CD playback you press [F2], does the display change to (Stop) and the CD playback stop?
When you press F3 (>>|), does the CD jump to the beginning of the next song?
When you press F1 (|<<), does the CD jump to the beginning of the previous song?
When you press F4 (1Trk), does the CD jump to the beginning of the first song?
6. If there is a problem with even one of the above items, change the CDP Driver Type setting and try again. Repeat steps 1 to 5. If you find a setting number that works correctly, use that number thereafter.

● **Saving the setting**

The CDP Drive Type setting will be lost if you turn the power off. Use the following procedure to save the setting.

LCD procedure

1. Press MODE. The Mode Menu will appear.
2. Press F6 (System). The System Mode display will appear.
3. Press VALUE/MENU (PUSH). The System Menu will appear.
4. Move the cursor to 5:LD/SV SysPRM, and press S1/DEC (Open). The Load/Save System Parameter display will appear.
5. Press F3 (SavePRM). The CDP Driver Type settings will be saved in the system backup memory inside the S-760.

CRT procedure

1. From the System MENU, select LD/SV SysPRM. The Load/Save System Parameter display will appear.
2. Click F3 (SavePRM). The CDP Driver Type settings will be saved in the system backup memory inside the S-760.

Sampler System Software
S-760 Ver.2
Power Sampling Expansion
OP-760-1

Owner's Manual

Introduction

Thank you for purchasing the Roland S-760 Ver.2 Digital Sampler or the OP-760-1 Power Sampling Expansion. In order to take full advantage of the S-760 System Software Ver.2 / the OP-760-1 and enjoy long years of trouble-free use, please read "Attention all S-760 users" leaflet and then this manual carefully.

How to use this manual

This manual is organized as follows.

Chapter 1. Functions added/modified in Ver.2

This chapter separately explains the functions which can be used even when an OP-760-1 is not installed, and the functions which can be used when an OP-760-1 is installed.

Chapter 2. Before you use the OP-760-1

This chapter explains the rear panel, and how to make connections.

Chapter 3. Operation using the CRT display and mouse/RC-100

This chapter explains how to switch from front panel operation to operation using a CRT display and mouse or an RC-100.

Chapter 4. Differences in function/operation between the LCD display and CRT display

The functions available and the operating procedures will differ depending on whether you are using the LCD display or using a CRT display to operate the unit. This chapter explains these differences. In some cases you will operate the unit from the front panel even when an OP-760-1 is installed. They are not covered in Chapter 1 "Functions added/modified in Ver.2", so be sure to read this chapter carefully.

Chapter 5. Sound data compatibility between Ver.1 and Ver.2

Some sound data parameters have been added/modified in Ver.2. This chapter explains how data compatibility is affected.

Chapter 6. Appendix

This chapter contains lists of the sound data and system parameter that have been added/modified in Ver.2. It also explains how to clean the mouse, troubleshooting, etc.

Main features

S-760 System Software Ver.2

- The rich functionality of S-760 Ver.1 and its consistent user interface has been maintained. You can enjoy sampling without a great deal of prior knowledge being necessary.
- A system parameter Continuous Pan On/Off has been added. When a MIDI Pan control change message is received during performance, the pan position of the currently sounding note will change immediately. (In Ver.1, the new pan position took effect from the next played note.)
- A new Solo/Mute function has been added which you may set for specified parts. This allows you to sound only the Part you wish to edit, or turn off unwanted Parts without having to turn off the MIDI channel of the Part.
- Stereo Edit Mode has been added to the Partial SMT. When a stereo sample is assigned to components of the SMT, this allows you to set the same parameters for the L and R SMT.
- Volume Dump can be saved on floppy disk. This means that you can save volume data even on system configurations such as S-760 + CD-ROM drive. In Ver.1, Volume Dump could be saved only by using a MIDI sequencer.
- S-550/W-30 floppy disk sound data can be Convert Loaded. In addition to the S-550/W-30 sound data stored on CD-ROM or hard disk, you can immediately convert load the great variety of sound data available on floppy disk.

Power Sampling Expansion (OP-760-1)

- A mouse and CRT display can be connected for more visual operation. One of three types of display can be selected: a home television that has a video input jack, a home television that has an S-video input, or a 200 line digital RGB monitor. All three types are color displays. A separately sold remote controller (RC-100: discontinued) can also be connected.
- One pair of stereo digital audio inputs and two pairs of stereo digital audio outputs can be used, allowing data transfers with CD, DAT, MD, or other digital audio systems without compromising the sound quality.
- * **The use of data sampled from copyrighted CDs or tapes for any purpose other than personal use, including commercial uses such as music production, performance or broadcasting, is prohibited by law unless written permission is received from the copyright owner.**

Contents

How to use this manual.....	0-2
Main features.....	0-3

Chapter 1. Functions added/modified in Ver.2

Functions usable even when an OP-760-1 is not installed ...	1-2
Functions usable when an OP-760-1 is installed.....	1-2
Explanation of added/modified functions.....	1-3
Performance mode.....	1-3
Solo/Mute.....	1-3
Pan setting range.....	1-4
Sample Delete function for Listen Delete.....	1-4
Part Channel Sort.....	1-4
CD Player function.....	1-5
Split procedure for Quick Sampling.....	1-5
Volume Information.....	1-6
Patch mode.....	1-6
One Shot mode.....	1-6
LFO Pan Depth.....	1-6
Partial mode.....	1-7
SMT stereo edit mode.....	1-7
Sample Pan parameter range has been expanded ((LF+), (LF-) added).....	1-7
LFO Pan Modulation Depth has been added.....	1-7
Disk mode.....	1-8
Convert Load from floppy disk.....	1-8
Volume Dump to floppy disk.....	1-8
Selecting the type of sound data to be overwritten.....	1-9
Selecting the type of sound data to be deleted.....	1-9
Cancelling a command.....	1-10
File count display during loading.....	1-10
Disk Copy.....	1-10
Displaying the name of a CD-ROM disk.....	1-10
Automatic Cancel for loading errors.....	1-11
Overwrite Switch.....	1-11
System mode.....	1-11
Continuous Pan switch.....	1-11
Analog Input Monitor.....	1-12
Mark list.....	1-12
Name History function.....	1-12
Digital input/output functions.....	1-13

Chapter 2. Before using the OP-760-1

Rear panel.....	2-2
Making connections.....	2-3
Connecting the display.....	2-3
Connecting the mouse/RC-100.....	2-4
Connecting digital audio devices.....	2-4

Chapter 3. Operation using the CRT display and mouse/RC-100

Selecting the controller.....	3-2
Selecting the controller during start-up.....	3-2
Selecting the controller after start-up.....	3-2
If you make an incorrect selection.....	3-2

Basic operation.....	3-3
The CRT display screen.....	3-3
About the mouse.....	3-4
Mouse operation.....	3-5
Opening various mode displays.....	3-5
Opening the Mark display.....	3-5
Opening the Jump display.....	3-5
Opening the Command display.....	3-5
Closing a display.....	3-5
Modifying parameter values.....	3-5
Messages.....	3-5
Scrolling a list.....	3-5
RC-100 operation.....	3-6

Chapter 4. Differences in function/operation between the LCD display and CRT display

Functions usable only when a CRT display is connected.....	4-2
Selecting sounds / Modifying sound names.....	4-2
Keyboard display.....	4-2
Part Map.....	4-2
Performance Equalizer display.....	4-3
Mouse operation in the TVF/TVA envelope displays.....	4-3
Mouse operation in the Wave Graph display.....	4-3
Functions which use different data for LCD display or CRT display.....	4-4
Mark List.....	4-4
Functions which are operated differently for LCD display or CRT display.....	4-4
Some commands have been moved to a menu.....	4-4
Disk Load.....	4-4
Assigning names.....	4-4
About the wave graphic display.....	4-5
How to view the wave graphic.....	4-6
How to set the waveform points (parameters).....	4-9
Basic procedure.....	4-9
Select a sample.....	4-9
Finding the approximate location.....	4-9
Zoom in the graphic.....	4-9
Set the location of the edit point.....	4-9

Chapter 5. Sound data compatibility between Ver.1 and Ver.2

Sound data compatibility between Ver.1 and Ver.2.....	5-2
---	-----

Chapter 6. Appendix

List of parameters added/modified in Ver.2.....	6-2
Cleaning the mouse.....	6-3
Troubleshooting.....	6-4
Specifications.....	6-5

Chapter 1

Functions added/ modified in Ver.2

A variety of parameters and functions have been added in Ver.2. Also, some of the existing functions have been enhanced and made easier to use. This chapter explains the functions which have been added/modified.

In the explanatory text,

Perform indicates a Performance parameter,

Patch indicates a Patch parameter,

Partial indicates a Partial parameter,

System1 indicates a System parameter saved on the system disk, and

System2 indicates a System parameter saved in the system backup memory inside the S-760.

Functions usable even when an OP-760-1 is not installed

Performance mode

- Solo/Mute has been added (Ver.2 p.1-3)
- The range of settings for Pan in the MIDI Filter page has changed (Ver.2 p.1-4)
- A Sample Delete function has been added in Listen Delete (Ver.2 p.1-4)
- Part Channel Sort has been added (Ver.2 p.1-4)
- A CD Player function has been added (Ver.2 p.1-5)
- The split method in Quick Sampling has changed (Ver.2 p.1-5)
- The range of settings for Positional Crossfade area has changed (Ver.2 p.1-6)
- Volume Information has been added (Ver.2 p.1-6)

Patch mode

- One Shot mode has been added (Ver.2 p.1-6)
- LFO Pan Depth has been added (Ver.2 p.1-6)

Partial mode

- Stereo Edit mode has been added to SMT (Ver.2 p.1-7)
- The range of parameter settings for Sample Pan has been expanded ([LF+],[LF-]) (Ver.2 p.1-7)
- LFO Pan Modulation Depth has been added (Ver.2 p.1-7)

Disk mode

- A function for Convert Load from floppy disk has been added (Ver.2 p.1-8)
- A function for Volume Dump to floppy disk has been added (Ver.2 p.1-8)
- A function for selecting types of sound data to overwrite has been added (Ver.2 p.1-9)
- A function for selecting types of sound data to delete has been added (Ver.2 p.1-9)
- A Command Cancel function has been added (Ver.2 p.1-10)
- A function to display the number of Performance and Patch files used by a Volume has been added (Ver.2 p.1-10)
- A function to specify the order during disk copying has been added (Ver.2 p.1-10)
- A function for displaying the name of a CD-ROM disk has been added (Ver.2 p.1-10)
- An automatic cancel function for loading errors has been added (Ver.2 p.1-11)
- An Overwrite Switch has been added (Ver.2 p.1-11)

System mode

- Continuous Pan has been added (Ver.2 p.1-11)
- An Analog Input Monitor function has been added (Ver.2 p.1-12)
- The range of settings for Mark List has been expanded (Ver.2 p.1-12)
- A Name History function has been added (Ver.2 p.1-12)

Functions usable when an OP-760-1 is installed

- Digital input/output functions (Ver.2 p.1-13)
- Operation using a CRT display and mouse (Ver.2 p.3-1)

Explanation of added/modified functions

This section explains the functions which have been added. For some functions, the operation is different depending on whether you use the LCD or the CRT display and mouse. Follow the directions appropriate for your setup.

* For operation using a CRT display and mouse, refer to p.3-1.

Performance mode

Solo/Mute

You can specify Solo/Mute for a desired Part. This is useful when you wish to hear or mute only a specific Part.

If you set a Part to Solo, only that Part will sound. Solo can be set only for one Part at a time. If you set a Part to Mute, that Part will not sound. Mute can be set for more than one Part.

* If you set both Solo and Mute for a Part, Mute will take priority, and that Part will not sound.

Solo/Mute

(Solo/Mute) **Perform** [S], [M]

[S]: Specify Solo for the Part. Only the specified Part will sound.

[M]: Specify Mute for the Part. The specified Part will not sound.

LCD operation:

In the Performance Play page, press F3 Sol/Mut (Solo/Mute). The Solo/Mute page will appear.

Move the cursor to the Part you wish to Solo or Mute.

Select Solo or Mute for the Part. The number and patch name of the Part at the cursor location will be displayed.

If you move the cursor to the "*" of Mute and press S2/INC, all 8 Parts will be muted simultaneously. If you press S1/DEC, muting will be canceled.

Press EXIT to return to the Performance Play page. In the Performance Play page, Solo/Mute status is displayed in the Ch position. A Part for which Solo is selected will be displayed as "S", and Parts for which Mute is selected will be displayed as "M". When not soloed, un-muted Parts will be displayed as "*".

CRT operation:

In the Performance Play page, click F3 Sol/Mut (Solo/Mute). The Solo/Mute page will appear.

Move the mouse cursor to the Part you wish to Solo or Mute.

To specify Solo, click "S". To specify Mute, click "M." To cancel solo or mute, click once again. Solo/Mute status is indicated by a red rectangle.

If you click "All ↑" at the bottom of the page, all 8 Parts will be muted simultaneously. If you click it once again, muting will be canceled. Click the right mouse button (Exit) to return to the Performance Play page. In the Performance Play page, Solo/Mute status is displayed in the Ch position. A Part for which Solo is selected will be displayed as "S", and Parts for which Mute is selected will be displayed as "M". When not soloed, un-muted Parts will be displayed as "*".

Pan setting range

In the MIDI Filter page, you can turn Pan data (control change #10) reception on/off, and specify how pan will change when the data is received.

Pan

(Pan) **Perform** [-], [C], [D]

[-]: Pan data will not be received.

[C]: If Pan data is received while a note is sounding, the pan position will change in realtime.

[D]: Even if Pan data is received while a note is sounding, the pan position will not change. The new pan position will take effect from the next note.

In Ver.1, [C] could not be selected, and it was not possible to move the pan position while a note was sounding.

- * In order to move the pan position while a note is sounding, you also need to make system parameter settings. Refer to "Continuous Pan" (Ver.2 p.1-11).
- * If you move the pan position while a note is sounding, noise may appear for some sound data. In such cases, select [D].

Sample Delete function for Listen Delete

By executing Listen Delete (Advanced Operation p.5-5, Advanced Operation p.6-5), Samples used by a Partial which is turned off for a Split in the Patch can be deleted from internal memory. This allows you to delete unneeded Samples in order to conserve internal memory. In Ver.1, the unneeded samples could not be deleted, so the amount of available internal memory was not changed by executing Listen Delete.

LCD/CRT operation:

Open the Listen Delete page.

Execute Listen Delete as explained in "How to avoid saving unwanted sounds" (Advanced Operation p.6-5).

Select the Patch for which to execute Listen Delete, and the display will ask "Delete Partials and Samples." If you wish to delete samples, select Yes. If not, select No.

- * If you are using a CRT display and mouse, open the Listen Delete page from the Performance Menu rather than from Performance Command (Ver.2 p.4-4).

Part Channel Sort

This function sorts the Patch and Part settings assigned to a Part in ascending order of their MIDI channels, starting with Part 1.

LCD/CRT operation:

Open page 1 of the Performance Utility display (Advanced Operation p.5-6).

Select F2 Ch Sort.

- * If you are using a CRT display and mouse, open the Performance Utility page from the Performance Menu rather than from Performance Command (Ver.2 p.4-4)

CD Player function

This function allows you to use a CD-ROM drive connected via SCSI as an ordinary CD player. The CD player display shows the following information.

CD-ROM drive name

Type of disk:

-A-: audio disk (an ordinary CD)

-D-: sound data disk (CD-ROM)

Total number of songs on the disk and total playing time

Currently playing song number and playing time

Operation buttons

*** Depending on the CD-ROM drive you are using, there may be a message of "Not Supported. Please change Current Drive." In this case, the CD Player function cannot be used.**

LCD operation:

Insert the audio disk you wish to play into the CD-ROM drive, and specify the Current Drive (Basic Operation p.2-7).

From Performance Command, select 8:CD Player. The CD Player window will open.

Press the desired function button.

F1:	skip to previous song.
F2 Play/Stop:	play/stop
F3:	skip to next song
F4 Trk1:	skip to beginning of disk

CRT operation:

Insert the audio disk you wish to play into the CD-ROM drive, and specify the Current Drive (Basic Operation p.2-7).

From Performance Command, select CD Player. The CD Player window will open.

Click the desired operation button.

[Play/Stop]:	play/stop
[>>]:	skip to next song.
[<<]:	skip to previous song
[Trk1]:	skip to beginning of disk

When you click Track, a numeric keypad display will appear, allowing you to directly select the song you wish to play.

Split procedure for Quick Sampling

After sampling, when you set the Split Mode to 1Key and assign a Partial to the keyboard, the Original Key (Advanced Operation p.3-42) of the sample will not be rewritten even if you modify the key number. Also, Pitch Key Follow (Advanced Operation p.3-24) will be set Off. This means that you can split a Partial to a key number that is different than the Original Key, and the Partial will still be sounded at the same pitch as the Original Key.

In Ver.1 when you modified the Key Number, the Original Key was also rewritten.

LCD/CRT procedure:

Refer to "Record a sample" (Basic Operation p.3-4) and execute Performance Quick Sampling.

Specifying the keyboard range of a Part

You can set any desired Part to a specified single key.
In Ver.1, the keyboard range for a Part had to be two or more keys.

LCD/CRT operation:

Follow the procedure given in "Part Split and Positional Crossfade" (Advanced Operation p.6-24) to make Part Split settings.

Volume Information

The number of each type of sound data in internal memory will be displayed. The amount of wave memory installed in the S-760 will also be displayed.
In Ver.1, volume information could be checked only in Disk mode or System mode, but now you can view it in Performance mode as well.

LCD/CRT operation:

In the Performance Play page, select VolInfo.

Patch mode

One Shot mode

For the Partials assigned to the selected Patch, all Samples will be played as though the Loop Mode had been set to One Shot mode. This is useful when you wish to check the looping of phrase-sampled sounds. The actual Loop Mode of the Samples will not be changed.

*** If the Loop Mode is Rev One or Rev, the Samples will be played with a setting of Rev One.
For other Loop Modes, the Samples will be played as One Shot.**

1Shot Mode

(One Shot Mode) Patch [Off], [On]

[Off]: All Samples will be played with their Loop Mode unchanged.
[On]: All Samples will be played with their Loop Mode as 1Shot/Rev One.

LCD/CRT operation:

Open the Patch Common page (Advanced Operation p.3-13).
Select 1Shot Mode.

LFO Pan Depth

In the Patch Control page (Advanced Operation p.3-18), pan position can be controlled by a LFO (the stereo position will be cyclically moved between left and right). The depth of this movement can be controlled by aftertouch messages, modulation messages, or control change messages.

A.T LFO-Pan Depth (Aftertouch LFO Pan Depth) Patch [-63]-[63]

Aftertouch messages will control the depth of LFO panning.

Mod LFO-Pan Depth (Modulation LFO Pan Depth) Patch [-63]-[63]

Modulation messages will control the depth of LFO panning.

Ctrl LFO-Pan Depth (Control Change LFO Pan Depth) Patch [-63]-[63]

Control Change messages will control the depth of LFO panning.

Partial mode

SMT stereo edit mode

Stereo samples found in the Partial SMT page and assigned to components can be edited simultaneously for both samples L and R. This allows you to set the two samples to identical values when setting parameters such as Pitch Key Follow, Coarse Tune, or Level.

In Ver.1, it was not possible to simultaneously edit both samples of a stereo pair.

LCD/CRT operation:

Open the Partial SMT page (Advanced Operation p.3-24).

Press F2 Mono/Stereo to select the edit mode.

If Stereo is selected, you will be able to simultaneously edit the SMT parameters of the samples assigned to components 1 and 2 (or 3 and 4). However, Sample Select cannot be edited simultaneously. This parameter must be set separately for each sample.

- * You can also move the cursor to the “ * [1]” (or “ * [3]”) in the left of the display, and click the mouse to automatically assign a stereo sample to components 1 and 2 (or 3 and 4).
- * If Stereo is selected, components 1 and 2 (or 3 and 4) will be edited simultaneously even if mono samples are assigned to them.

Sample Pan parameter range has been expanded ([LF+],[LF-] added)

In the Partial SMT page, the pan position of each Sample can be modulated by an LFO. Refer to “Sample Pan” (Advanced Operation p.3-26) as you read this section.

Pan

(Sample Pan) Partial [L32]-[0]-[R32], [Rnd], [Ky+], [Ky-], [LF+], [LF-], [Alt]

When [LF+] or [LF-] are selected, Sample Pan will be at 0 (center), and this pan position will be modulated left and right by the LFO. The depth of pan modulation is determined by Pan Modulation Depth (Ver.2 p.1-7). [LF+] and [LF-] have opposite LFO phases.

LFO Pan Modulation Depth has been added

In the Partial LFO page, the pan position of each Sample can be modulated by an LFO.

Pan Depth

(Pan Depth) Partial [-63]-[63]

This parameter sets the depth of the LFO Pan modulation.

The sound will be moved cyclically between left and right, creating a tremolo effect. For negative settings, the phase of the LFO waveform will be inverted.

- * This setting is valid only if Sample Pan (Ver.2 p.1-7) is set to [LF+] or [LF-].

Disk mode

Convert Load from floppy disk

You can Convert Load S-550/W-30 floppy disk sound data into the S-760.

In Ver.1, the Convert Load function could be used only for external SCSI devices such as CD-ROM disks.

- * **Due to differences in the parameter structure and the analog circuitry, sounds may appear different.**

LCD/CRT operation:

Set the Current Drive to floppy disk (Basic Operation p.2-7).

Follow the procedure given in "Convert Load" (Advanced Operation p.3-88) to execute Convert Load.

- * **It is not possible to Convert Load sound data floppy disks of other manufacturers.**
- * **It is not possible to Convert Load sound data floppy disks of S-50.**

Volume Dump to floppy disk

Parameter data for the sounds used by the Volume in internal memory can be saved to a floppy disk. A 2DD disk can contain a maximum of 4, and a 2HD disk can contain a maximum of 8 Volume Dumps. When this data is loaded, the appropriate Samples will be loaded from all drives which are connected to the SCSI connector just as when a Volume is loaded into internal memory.

You can perform a Volume Dump even if your system is a S-760 + CD-ROM drive.

In Ver.1, a MIDI sequencer was necessary to perform a Volume Dump.

- * **Samples that can be Volume Dumped are subject to the following restrictions. Read Advanced Operation p.6-8 together with the following discussion.**

1. If you have saved a Volume Dump with modified Sample parameters (Loop Mode, Loop Start Point etc.), the Sample parameter changes will be ignored. When the Samples are loaded, the Sample parameters will have the values of when they were first loaded (i.e., the values before modification). However the modified Original Key settings will be preserved (but no other parameters).
2. In Ver.2, all Samples used by a Volume can be loaded even if they are saved on two or more drives. When the exclusive data has finished being loaded from a MIDI sequencer, or when the data has finished being loaded from floppy disk, the S-760 will first search for samples in the current drive. If the required samples are not in the current drive, it will search the SCSI devices starting with the device with the lowest ID number. This means that if two or more drives contain identically-named samples, an incorrect sample may sometimes be loaded.
Normally, you should load all sound data from a single drive, and set this drive as the current drive before you execute Volume Dump.

LCD/CRT operation:

Save procedure

1. Insert the floppy disk you wish to use for the Volume Dump into the disk drive.
2. From the Disk menu, open the Volume Dump FD page.

- * **Even if the disk has already been formatted by the S-760, if it has not been initialized for Volume Dump you will be asked whether or not it is ok to initialize it. If you answer Yes, the floppy disk will be initialized and then the Volume Dump FD page will appear.**

3. Mark the numbers of the data you wish to save.
4. Select F1 Save.

Load procedure

1. Connect the drive containing the Samples used by the Volume, and turn on the S-760 power.
 2. Insert the floppy disk in which the Volume Dump data was saved into the disk drive.
 3. From the Disk menu, open the Volume Dump FD page.
- * If you are loading data from a Volume Dumped floppy disk into the S-760, be sure to use the Volume Dump FD page. If you attempt to load it from the Disk Load page, a message of "It's VolumeDumpDsk" will appear, and loading will not be possible.
4. Mark the data you wish to load.
 5. Select F3 Load.
- * If you attempt to load data from a Volume Dumped floppy disk into an S-770/750, a message of "Not Formatted" will appear, and loading will not be possible.
 - * By selecting F4 Delete, you can delete the marked data.

Selecting the type of sound data to be overwritten

When you overwrite (Load) sound data in internal memory, or overwrite (Save) sound data from internal memory to a SCSI device such as a hard disk, or overwrite (Disk Copy) data between SCSI devices, you can specify that only the necessary types of sound data (of the various types Volume/Performance/Patch/Partial/Sample) will be overwritten. If you have not edited or marked Samples, you can overwrite just the sound parameter data, thus shortening the time taken by the Overwrite operation. Normally, you will mark all sound data and execute the Overwrite operation.

LCD/CRT operation:

Turn off the Overwrite Switch (Advanced Operation p.3-96) and as explained in "Overwrite" (Basic Operation p.8-12) execute the Overwrite operation. A message of "Same Name! Overwrite?" and the number of each type of sound data will appear, so that you can check whether you wish to overwrite the identically named data.

Mark the sound data you wish to overwrite.

Yes: The marked sound data will be overwritten (Load/Save/Disk Copy), and the sound data with different names will be Loaded/Saved/Disk Copied.

No: Only the sound data with differing names will be Loaded / Saved / Disk Copied.

Cancel: Cancel the Load/Save/Disk Copy operation.

Selecting the type of sound data to be deleted

When deleting sound data from a SCSI device such as a hard disk, you can specify that only the unwanted types of sound data (of the various types Volume/Performance/Patch/Partial/Sample) be deleted. If you have not marked samples, you can delete just the sound parameters data, thus shortening the time taken by the Delete operation. Normally, you will mark all sound data and execute the Delete operation.

LCD/CRT operation:

As explained in "Disk Delete" (Advanced Operation p.3-79), execute the Delete operation. The numbers of each type of sound data will appear, and a message will ask you whether it is ok to execute the Delete operation.

Mark the sound data you wish to delete.

Yes: The marked sound data will be deleted.

No: The Delete operation will be canceled.

- * If Fast Delete Mode (Advanced Operation p.3-95) has been turned Off, sound data used by other sound data of a higher level will not be deleted even if it has been marked.

Canceling a command

When executing a command in Disk mode, it is possible to Cancel the command. This means that as long as the file is still being scanned, it is possible to stop the operation if you notice your mistake in time.

- * If data transfer is already taking place with the current disk, it is not possible to cancel the operation.

LCD/CRT operation:

Execute a command in a Disk mode page.

While the files are being scanned, there will be a display of “([EXIT] for Cancel)”. While this message is displayed, you can select EXIT by pressing the front panel button EXIT or by clicking the right mouse button.

File count display during loading

The Disk load page displays the Performance names and Patch names used by the Volume you wish to load. This allows you to check the number of sound data items when loading.

In Ver.1 you could see only the size of the entire Volume.

LCD operation:

As explained in “Disk Load” (Advanced Operation p.3-70), open the Disk Load page. Move the cursor to the sound data you wish to load, and press S2/INC (Info). The Performance names and Patch names used in that Volume will be displayed. Use S1/DEC and S2/INC or the value knob to scroll the list.

CRT operation:

As explained in “Disk Load” (Advanced Operation p.3-70), open the Disk Load page. Move the cursor to the sound data you wish to load, and click the right mouse button (Info). The Performance names and Patch names used in that Volume will be displayed. Use the scroll switches to scroll the list.

Disk Copy

When copying two or more sounds from hard disk/magneto-optical disk to hard disk/magneto-optical disk, you can specify the order in which the sound data will be copied. This allows you to change the order of the sound data list displayed for the destination drive.

In Ver.1, sound data was copied in numerical order starting with the lowest numbered data.

LCD/CRT operation:

Make Disk Copy settings as explained in “Disk Copy” (Advanced Operation p.3-75).

Mark the sound data you wish to copy in the order you wish it to be copied.

Select F3 Copy. Disk Copy will be executed.

Displaying the name of a CD-ROM disk

In the Select Drive page, you can check the name of a CD-ROM disk in a drive connected to the S-760.

In Ver.1, connected CD-ROM drives were displayed as CD-ROM DRIVE, and the disk name was not displayed.

LCD/CRT operation:

Open the Select Drive page as explained in “Select Drive display” (Advanced Operation p.5-14).

Automatic Cancel for loading errors

If you attempt to load sound data that will not fit into internal memory, an error message of "IError:Wave Memory Full" will appear. Also, if you attempt to load more than the allowable number of sound data, an error message of "IError:Directory Full" will appear. In these cases, loading will immediately be halted. "/Skip" will be displayed at the right of the names of sound data that was not loaded. In Ver.1, loading continued even though the error message appeared.

LCD/CRT operation:

Execute sound data loading as explained in "Disk Load" (Advanced Operation p.3-70).

Overwrite Switch

This is the setting for the overwrite message (Advanced Operation p.3-96).

In Ver.1 the overwrite setting was set in System mode, but now you can set this from Disk mode as well.

LCD/CRT procedure:

In Disk Load, Disk Save, or Disk Copy pages, select F4 OW On/Off.

System mode

- * If you turn the power off without saving System parameters, all the data will be lost. Be sure to save before turning the power off. System parameters can be classified into two groups depending on the location where they are saved. For details refer to "Loading/Saving the system" (Basic Operation p.8-7).

Continuous Pan switch

The pan position of currently sounding notes can be changed by incoming MIDI Pan control change data. In Ver.1, the new pan setting took effect when the next note was played.

Continuous Pan (Continuous Pan Switch) System2 [Off], [On]

[Off]: When pan data is received, the new pan position will take effect when the next note is played. (The pan position will not change in realtime.)

[On]: When pan data is received, the pan position will change in realtime while the note is sounding.

LCD/CRT operation:

Open the System Parameter page (Advanced Operation p.3-91).

Make the desired setting for Continuous Pan (Continuous Pan Switch).

- * If you want pan to change while the note is sounding, you must also make Performance parameter pan settings. In the MIDI Filter page, select C (Continuous) (Ver.2 p.1-4).
- * If the pan position is changed while the note is sounding, you may notice noise in some sounds. In such cases, turn off the Continuous Pan switch.

Analog Input Monitor

When a page is open in any mode other than Sample mode, the audio signal coming into the analog inputs can be mixed with Stereo A (STEREO OUT 1) and output for monitoring. Even while commands such as Disk Load are being executed, you can monitor the analog audio or play the S-760 along with the incoming analog audio signal.

Analog Input Monitor (Analog Input Monitor) **System2** [Off], [1]-[127]

[Off]: The audio coming into the analog inputs will not be monitored.

[1]-[127]: This sets the monitoring level of the audio coming into the analog inputs.

LCD/CRT operation:

Open the System Parameter page (Advanced Operation p.3-91).
Make the desired Analog Input Monitor settings.

Mark list

(Mark list) **System1**

Ver.1 included a jump function using a mark list. In Ver.2 however, there are two mark lists: one for the LCD and one for the CRT. Together they allow you to register a total of 20 pages.

- * It is not possible to use LCD mark list data from Ver.1. For details, refer to the section "How to upgrade from Ver.1 to Ver.2" in the leaflet entitled "Attention all S-760 users".
- * For details on how to create a mark list, refer to Basic Operation p.7-8.

Name History function

Up to 20 names you assign to sounds or disk drives can be remembered. This is convenient when you want to reuse a name you assigned earlier with slight changes, or assign the same name to different types of sound data.

(Name History list) **System1**

Name History data is part of the System parameters which are saved to the system disk. If you turn the power off without saving, this data will be lost. For details on System parameters, refer to "Loading/saving the system" (Basic Operation p.8-7).

LCD/CRT operation:

Open the ASCII display (Basic Operation p.7-12, Ver.2 p.4-4).
Move the cursor to the up/down arrows located at the lower left of the ASCII keyboard.
Use the left/right mouse buttons, or S1/DEC and S2/INC or the Value knob to select from the list.

Digital input/output functions

These functions can be used when an OP-760-1 is installed. The OP-760-1 provides one digital input and two digital output jacks. This allows you to digitally sample sound from a DAT or CD player that has a digital output. You can also digitally output the sound of the S-760. Use coaxial cables to make digital input/output connections.

* For details on connections and operation, refer to p.2-3 and p.3-3.

Digital input

Connect the digital output of a CD player etc. to the digital input of the OP-760-1.

In the Sampling page, set Input (Advanced Operation p.3-44) to [Digital] so that you can sample the audio from the digital input.

Digital output

Connect a digital output of the OP-760-1 to the digital input of a DAT or other digital audio device. The output jack from which the equalized sound is sent will depend on the System parameters Output Mode and Output Assign.

Output Mode

4 stereo

Each Patch/Partial will be output in stereo. Stereo C will be output from DIGITAL OUT 1, and stereo D will be output from DIGITAL OUT 2.

Mix

Stereo B / stereo C / stereo D outputs will be mixed with stereo A and output as a single stereo signal. The output mixed into a single stereo signal will be sent from STEREO OUT 1 and DIGITAL OUT 1. Nothing will be output from DIGITAL OUT 2.

1 stereo + 6 out

Each Patch/Partial will be output in stereo or individually. Individual 5 and 6 will be output from DIGITAL OUT 1, and individual 7 and 8 will be output from DIGITAL OUT 2.

8 out

Each Patch/Partial will be output individually. Individual 5 and 6 will be output from DIGITAL OUT 1, and individual 7 and 8 will be output from DIGITAL OUT 2.

Output Assign

When the System parameter Output Assign is set to [C/D → A/B], the sound that would otherwise be sent from stereo C and D will be mixed into stereo A and B, and output as two stereo signals. After being mixed, the output of stereo A and B will also be output from stereo C and D.

* For details on the digital outputs, refer to "Output assignments" (Advanced Operation p.4-2).

MEMO

A graphic consisting of a grey halftone pattern at the top and a solid black rectangle below it. The text "Chapter 2" is written in white, italicized font within the black rectangle.

Chapter 2

Before using the OP-760-1

Refer to this chapter when you have installed an OP-760-1 and wish to use it.

Rear panel

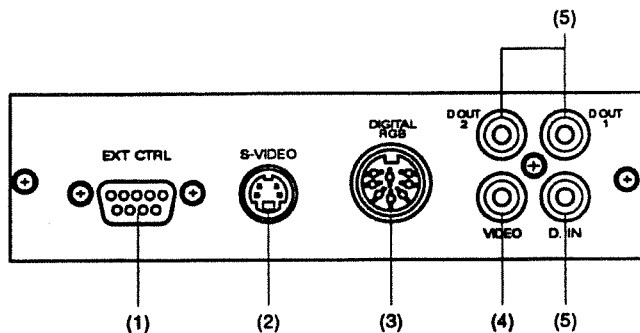

(1) EXT CTRL connector

The included mouse (MU-1) or a remote controller (RC-100: discontinued) can be connected here.

(2) S-VIDEO connector

A home television that has an S-video connector can be connected here.

(3) DIGITAL RGB connector

A 200 line CRT display with a digital RGB connector can be connected here.

(4) VIDEO connector

A CRT display or a home television that has a video input connector can be connected here.

(5) Digital I/O jacks

IN: When sampling, this jack inputs a digital audio signal.

OUT: These jacks digitally output two stereo pairs or four individual outputs. For details on the outputs, refer to "Equalizer and output jacks" (Basic Operation p.3-11) and "Output assignments" (Advanced Operation p.4-2).

* The digital I/O (COAXIAL) of the S-760 conforms to mode II (consumer equipment) of the AES/EBU digital audio interface format.

Making connections

Before you make connections, make sure that the power is turned off for all devices. If you make connections while the power is turned on, speakers or other equipment may be damaged.

Connecting the display

Operation will be more efficient if you can view a large number of functions at once and quickly select the desired function. For these reasons we recommend that you connect a CRT display, since it is able to display much more information than the LCD.

If you are using a CRT display or a home television that has a video input connector, connect it to the VIDEO connector.

If you are using a home television that has an S-video connector, connect it to the S-VIDEO connector.

If you are using a CRT display that has a digital RGB connector, connect it to the DIGITAL RGB connector.

Caution!!

CRT displays generate noise in audio equipment, so do not place your display on top of the S-760.

Caution when connecting a digital RGB CRT display

The DIGITAL RGB connector is for TTL RGB 200 lines. The output impedance is 100 ohms, and the specifications are as follows. If you connect an unsuitable display, the screen image may not be correct.

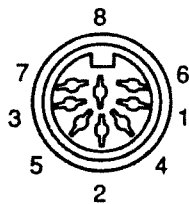

Pin No.	Signal		Specification
1	+5V	+5V power supply output	
2	GND	ground	
3	open		
4	HSYNC	horizontal sync signal output	TTL level negative polarity
5	VSYNC	vertical sync signal	
6	R	video output (red)	TTL level positive polarity
7	G	video output (green)	
8	B	video output (blue)	

RGB output time chart

Horizontal sync timing

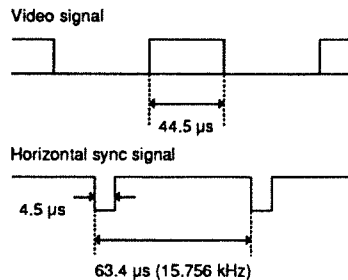

Vertical sync timing

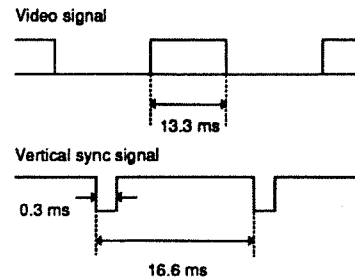

To connect a digital RGB CRT display, use only an RGB cable designed for that purpose. Do not under any circumstances use a cable with a connector that has a different shape or number of pins, or whose pin layout specifications are different.

- * For details on RGB cables, please carefully read the manual for your digital RGB CRT display.
- * Digital RGB CRT displays and RGB cables used for the S-50/550/330/770/750 can be used just as they are.
- * The explanations in this manual will assume that your system consists of the S-760 + CRT display + mouse / RC-100 + MIDI keyboard.

Connecting the mouse/RC-100

- * The EXT CTRL connector must never be connected to anything other than the mouse included with the OP-760-1 or an RC-100. Doing so will cause malfunctions.
- * The mouse included with the OP-760-1 is only for Roland S-series samplers. Do not use it with other devices, since doing so will cause malfunctions. A mouse that was included with the S-550/770/750 can also be used with the S-760.

Connecting the mouse

When the included mouse (MU-1) is connected, you can operate the S-760 using it as well as the front panel buttons, for increased efficiency.
Connect the included mouse to the OP-760-1 EXT CTRL connector.

- * After connecting the mouse, you also need to change the controller setting to "Mouse+CRT." For details refer to p.3-2.

Connecting the mouse and an RC-100

If you have a remote controller (RC-100: discontinued), you can connect both it and the mouse for even greater convenience of operation.
Connect the RC-100 to the OP-760-1 EXT CTRL connector. Connect the mouse to the RC-100 EXT CTRL (MOUSE) connector.

- * Be sure to connect the mouse to the RC-100 as well. If the mouse is not connected, you will not be able to use the dragging functions in the graphic display.
- * After connecting the mouse and RC-100, you also need to change the controller setting to "RC100+CRT." For details refer to p.3-2.
- * The RC-100 buttons are for the S-550. When using it with the S-760, refer to the buttons names on p.3-7.

Connecting digital audio devices

Use coaxial cables to make connections.

IN: Connect the digital output of a CD player etc. to the digital input of the OP-760-1. When sampling, this connector inputs the digital audio signal.

OUT: Connect the digital output of the OP-760-1 to the digital input of a DAT or other digital audio device. For details on the output, refer to "Equalizer and output jacks" (Basic Operation p.3-11) and "Output assignments" (Advanced Operation p.4-2).

Chapter 3

Operation using the CRT display and mouse/RC-100

By installing an OP-760-1 and connecting a CRT and mouse/RC-100, you can operate the S-760 System Software Ver.2 more visually and efficiently. This chapter explains how to switch the control over to the CRT and mouse/RC-100, and basic operation.

Note!

In order to use a CRT display and mouse/RC-100, you must start up using S-760 System Software Ver.2. Even if an OP-760-1 is installed, it cannot be used if system Ver.1 is used.

Selecting the controller

Simply connecting a CRT display and mouse/RC-100 does not allow them to be used. You must set the System parameter Controller (Advanced Operation p.3-92) to select the method of control. When the unit is shipped, this parameter is set to select operation from the LCD display and front panel buttons. You can select one of two methods of operation.

- * **You must select either the LCD display or the CRT display. It is not possible for them both to be displayed and used for operation.**
- * **After selecting control using the CRT, if you wish to operate the unit from the LCD display and front panel set the controller setting to [Panel+LCD].**

Selecting the controller during start-up

Refer to "Convenient ways to start-up" (Basic Operation p.6-2).

1. Turn the power on while pressing MODE. The Setup Menu page will appear.
2. Use the cursor buttons to move the cursor to Controller.
3. Use S1/DEC and S2/INC or the Value knob to select Controller.
If you wish to use the mouse, select "Mouse+CRT."
If you wish to use the mouse and an RC-100, select "RC100+CRT."
4. When you have finished making settings, press EXIT.
After startup, the Performance Play page will appear in the CRT display. The controller selection has now been rewritten. For this operation there is no need to save the System parameters.
5. If you are using an RC-100, be sure to press the reset button on the rear panel of the RC-100 when the Performance Play page appears.

Selecting the controller after start-up

1. Open the second page of the System Parameter display.
Press MODE.
Select F6:System.
Press the Value knob.
Select 1:System PRM.
Use the cursor button (down) to move the cursor to LCD Contrast, and press the cursor button (down) once again.
 2. Use S1/DEC and S2/INC to select Controller.
If you wish to use the mouse, select "Mouse+CRT."
If you wish to use the mouse and an RC-100, select "RC100+CRT."
 3. When you have finished making settings, press F3 Exec. CRT display and mouse/RC-100 operation has now been selected.
- * **If you are using an RC-100, be sure to press the reset button on the rear panel of the RC-100 when the Performance Play page appears.**
 - * **There are two types of System parameters. For details refer to Basic Operation p.8-5 and 8-7.**
 - * **For this operation there is no need to save the System parameters.**

If you make an incorrect selection

If you incorrectly select the control method, you will be unable to continue operation. Use the following procedure to reset the selection.

1. Turn off the S-760 power.
2. Use the procedure described in "Selecting the controller during start-up" to make the appropriate setting.

Basic operation

The screen display and the operating procedures are somewhat different depending on whether you are operating the S-760 from a CRT display or from the LCD display.

The CRT display screen

If the S-760 is started up with a controller selection of "Mouse+CRT" or "RC100+CRT," the CRT display will show the following screen. This is the basic Performance Play screen for S-760 System Software Ver.2.

- * Even if the Power Sampling Expansion (OP-760-1) has been installed, the CRT display will not show anything if the Controller setting is set to [Panel+LCD]. Either use the LCD, or change the Controller setting.

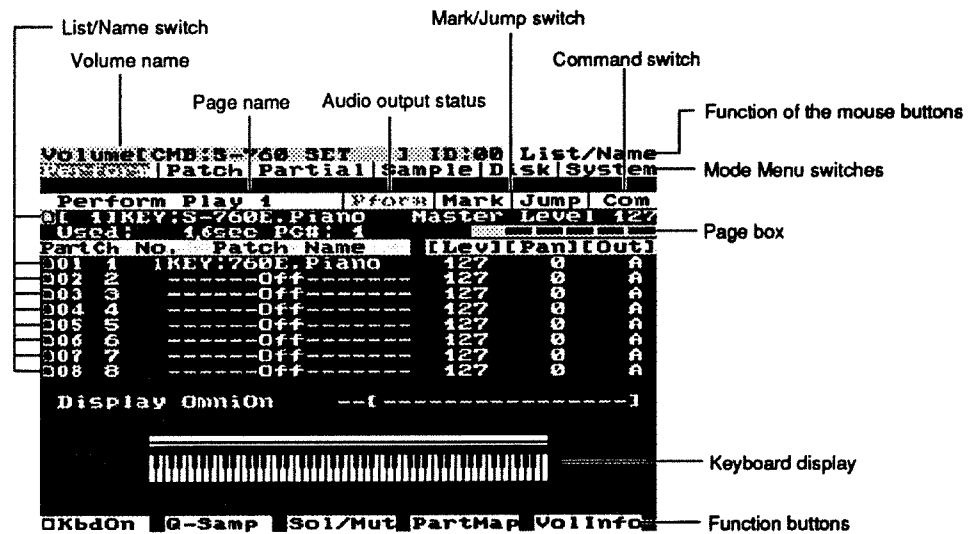

Note!

The illustrations of the display screen used by the explanations in this manual do not necessarily match the data (sound data names, etc.) that will be displayed with the factory settings.

Volume name

This always displays the name of the Volume in internal memory.

Mode Menu switches

These switches select the menu displays of the various modes. The mode of the currently shown screen is displayed in inverted red.

If a Disk mode or Sound Data edit display has been opened using the Command switch, the mode you were previously in will be indicated in inverted black.

The "inverted red" and "inverted black" indicators, together with the "Audio output status" indicator (explained below) are very important when editing sound data. For details, refer to "How to edit sounds" (Advanced Operation p.1-1). The explanation in that section is based on using the LCD display, so replace the words of the explanation as follows.

Meaning	LCD display	CRT display
Current mode	right-pointing triangle	inverted red display
Previous mode	plus	inverted black display
Audio output status	square	mode name

Audio output status

The audio output status is displayed as a mode name. When "Muted" appears, no sound will be output.

Mark/Jump switch

Use this switch to go directly to a desired page. The Mark display or Jump display will appear.

Command switch

The command menu for the currently selected mode will appear. Select the command page you wish to open.

List/Name switch

A list will open, allowing you to select the sound data you wish to edit. You can also change the name of sound data.

Page box

Some screens consist of two or more pages. The number of boxes indicates the number of pages, and the inverted box indicates the currently opened page.

Function buttons

The function of the function buttons is displayed in the bottom line of the screen. The display will depend on the function. Function buttons displayed as " --- " cannot be used.

1. Executing a command

The button will execute a command such as Load or Save. In this case the display consists only of characters.

2. Modifying a setting

The button will select a target in the display or change the edit mode. Each time you press the function button the setting will change, and the display indicates the current setting. In this case the display has a square mark as the first character.

* The function of the function buttons differs between the CRT display and the LCD display.

About the mouse

The mouse cursor

When you move the mouse across a level surface, the "+" symbol in the screen moves in the same direction. This "+" symbol is called the mouse cursor.

Moving the cursor

When you move the mouse cursor onto the characters of a parameter or command menu, that display will be inverted. This inverted display is called the cursor, and indicates the input location. In this manual, when we refer simply to "the cursor" we mean the inverted section of the screen, in distinction from "the mouse cursor."

In S-760 System Software Ver.2, nearly all operations can be performed simply by moving the mouse cursor to a parameter or command menu, and pressing a mouse button according to the mouse button functions displayed in the upper right of the screen. The following two basic operations are performed using the mouse.

Click

Moving the mouse cursor to a command menu etc. on the screen and pressing the mouse button is called "clicking."

For example, when this manual tells you to "click Com," it means to "move the mouse cursor to the Com display and press the left mouse button." Unless otherwise specified, press the left mouse button. The functions of the left and right mouse buttons are shown in the upper right of the display.

Drag

Moving the mouse while holding a mouse button is called "dragging."

In graphic displays, you will use this operation when editing envelopes, etc. Unless otherwise specified, hold down the left mouse button while you move the mouse.

Mouse operation

This section explains how to use the mouse in the CRT display. If you learn the following operations, you will be able to execute most operations simply by watching the screen.

Opening various mode displays

Click the desired Mode Menu switch. A menu for each mode will open, so click the name of the desired display. The currently selected display is indicated by a circular mark, and is displayed in red characters.

Some displays have two or more pages.

Click the page box in the upper right of the display to select the horizontally-arranged pages.

Opening the Mark display

Click the Mark switch to open the Mark display. For details on how to register display screens, refer to Basic Operation p. 7-8.

Opening the Jump display

Click the Jump switch to open the Jump display. Then click the name of the page to which you want to jump.

Opening the Command display

Click the Command switch to open the Command display. Then click the desired command.

*** If the Command switch is displayed in light blue characters, commands cannot be executed.**

Closing a display

To close a command menu etc., click the left or right mouse button. The indication of "Exit/Exit" in the upper right of the screen means that the left or right mouse button has the function of Exit.

Modifying parameter values

To modify a parameter value, move the mouse cursor to the value you wish to modify. Pressing the left mouse button will decrease the value, and pressing the right mouse button will increase the value. Each time you press a mouse button the value will change in individual steps, and if you continue holding the button the value will change more rapidly. The indication of "Dec/Inc" in the upper right of the screen means that the mouse buttons have the functions of Dec/Inc.

*** If while continuing to hold down a button you then press the other mouse button, the value will change even more rapidly.**

Messages

If executing a command would result in major changes to your data, or when performing especially important operations such as loading/saving data, a message will appear asking for confirmation. Click the appropriate message such as "Start", "Cancel", "YES", "NO", "Execute", etc. The upper right of the screen will indicate "Execute/---", meaning that the left mouse button has the function of Execute.

Scrolling a list

Some pages contain lists of sound data, such as the Disk mode displays or in the Command Select display. When there is a large amount of sound data, not all the sounds can be displayed at once. In such cases, move the mouse cursor to the sound data number. Pressing the right mouse button will scroll the list upward, and pressing the left mouse button will scroll the list downward. The upper right of the screen will indicate "Dec/Inc", meaning that the mouse buttons have the functions of "Dec/Inc".

Some pages, such as the Volume ID Select page, do not allow scrolling by number. In such cases, move the mouse cursor to the up/down switches (↓/↑). Pressing the right mouse button will scroll the list upward, and pressing the left mouse button will scroll the list downward.

RC-100 operation

If you have an RC-100 remote controller, you can use it together with a mouse for even more efficient operation. Mouse operations when connected to an RC-100 are the same as explained above. The RC-100 buttons will function as follows.

- * **The REC jack and START/STOP jack on the rear panel of the RC-100 cannot be used with the S-760.**

Roland
RC-100
REMOTE CONTROLLER

MOUSE

RESET

JUMP	F1	F2	F3	F4	F5	F6	MARK	HOME	
MODE COMMAND	S1	S2				7 STU	8 VWX	9 YZ/	
MENU	EXIT	▲				4 JKL	5 MNO	6 PQR	
		▼				1 ABC	2 DEF	3 GHI	
PREVIEW						0 +-*	ENTER	SPACE	
							DEC	INC	

VALUE

for S-760

MEMO

Chapter 4

Differences in function/ operation between the LCD display and CRT display

The usable functions and the operating procedures are somewhat different depending on whether you operate the S-760 using the LCD display or using the CRT display. This chapter explains these differences. In some cases you will be using the LCD display to operate the S-760 even though an OP-760-1 has been installed. "Functions added/modified in Ver.2" (Ver.2 p.1-1) does not discuss them, so please read this chapter carefully.

Functions usable only when a CRT display is connected

When Controller is set to [Mouse+CRT] or [RC100+CRT], several functions become available that were not available with a setting of [Panel+LCD].

Selecting sounds / Modifying sound names

To select sounds, move the mouse cursor to the List/Name Switch (Ver.2 p.3-4), and click the left mouse button. A sound select display will appear. Click the name of the sound you want to select.

* **When the cursor is located at a sound name, you can select sounds using either the left/right mouse buttons, S1/DEC or S2/INC, or the Value knob.**

When you click the right mouse button, an ASCII display will appear, allowing you to modify the sound name(Ver.2 p.4-4).

Keyboard display

This function allows you to check the currently sounding note numbers on the CRT display.

Display (Keyboard Display) [OmniOn], [Part 1]-[Part 32], [MIDI 1]-[MIDI 16]

When currently sounding notes are displayed on the keyboard, this setting specifies the MIDI channel or the Part for which playing status will be monitored. If you select OmniOn, the playing status of all MIDI channels will be monitored.

* **By pressing F1 you can turn off the keyboard display, allowing up to 16 Parts to be monitored on a single screen. Press F1 once again to return to the previous display.**

Part Map

This function allows you to check/modify the Patch parameters for each Part in the current Performance.

Parameter (Parameter)

This selects the contents of the Part Map display. The parameters that can be displayed and the range of their values are as follows.

Program Number	1 — 128
Patch Level	0 — 127
Patch Panning	L32 — 0 — R32
Output Assign	A — D,1 — 8,-P-
Patch Priority	Off,On
Octave Shift	-2 — 2
Coarse Tune	-48 — 48
Fine Tune	-50 — 50
Analog Feel	0 — 127
1Shot Mode	Off,On
Cutoff Offset	-63 — 63
Resonance Offset	-63 — 63
Attack Offset	-63 — 63
Release Offset	-63 — 63
Vel-Sens Offset	-63 — 63
SMT Ctrl Select	Off,bend,A.T,Mod,Ctrl
SMT Ctrl Sens	-63 — 63
Ctrl Select#	0 — 95
Bender Pitch Up	0 — 48
Bender Pitch Down	0 — 48
Bender TVF	-63 — 63
Bender TVA	-63 — 63
A.T Pitch	-48 — 48

A.T TVF	-63 — 63
A.T TVA	-63 — 63
A.T LFO Rate	-63 — 63
A.T LFO Pitch	-63 — 63
A.T LFO TVF	-63 — 63
A.T LFO TVA	-63 — 63
A.T LFO Pan	-63 — 63
Mod LFO Rate	-63 — 63
Mod LFO Pitch	-63 — 63
Mod LFO TVF	-63 — 63
Mod LFO TVA	-63 — 63
Mod LFO Pan	-63 — 63
Ctrl Pitch	-48 — 48
Ctrl TVF	-63 — 63
Ctrl TVA	-63 — 63
Ctrl LFO Rate	-63 — 63
Ctrl LFO Pitch	-63 — 63
Ctrl LFO TVF	-63 — 63
Ctrl LFO TVA	-63 — 63
Ctrl LFO Pan	-63 — 63

Performance Equalizer display

The Performance Equalizer display shows the equalizer parameters. These parameters can be controlled by the System parameter MIDI EQ Control (control change messages) (Advanced Operation p.3-100). The left side of the Performance Equalizer display shows the equalizer parameters and the right side shows the MIDI EQ controls.

Mouse operation in the TVF/TVA envelope displays

For more efficient editing, you can use the mouse to edit the Cutoff Frequency and Volume Level envelopes. Place the mouse cursor at a point of the envelope, and drag it. The lines connecting the points will stretch, and the time and level values of the points will change.

Mouse operation in the Wave Graph display

You can use the mouse to modify the locations of each wave data point, or to playback the wave data. For details refer to p.4-5.

Functions which use different data for LCD display or CRT display

Mark List

The display page structure differs between the LCD display and the CRT display. For this reason, there are two mark lists: one for the LCD and one for the CRT.
To register a display page in the mark list, refer to "Directly opening a display (Jump)" (Basic Operation p.7-8).

Functions which are operated differently for LCD display or CRT display

Some commands have been moved to a menu

When you are using a CRT display, the Listen Delete function (Advanced Operation p.5-5) and the Performance Utility functions (Advanced Operation p.5-6) are located not in Performance Command but in Performance Menu. Operating procedure is the same as when opening other displays in Performance mode.

Disk Load

This function loads sound data from the current drive into the S-760 internal memory. When you are using a CRT display, you must mark the sound. Unmarked sounds cannot be loaded.

- * Load the desired sound data as explained in "Disk Load" (Advanced Operation p.3-70).

Assigning names

In the CRT display when the cursor is located at the ASCII keyboard>L3

Move the supplementary cursor to the location where you wish to input the name, move the mouse cursor to the character you wish to input, and click the left mouse button (Type).

Moving the supplementary cursor

Click the left/right arrows located at the lower right of the ASCII keyboard.

Switching between lowercase/uppercase characters

While holding down the right mouse button, click the character you wish to input. When inputting uppercase characters, the SHIFT indicator will light.

Deleting a character

Move the supplementary cursor to the character you wish to delete, and click [DEL].
Or, move the supplementary cursor to the character following the one you wish to delete, and click [BS].

In the CRT display when the cursor is located at the name

Move the mouse cursor to the location where you wish to input the name, and click the left/right mouse buttons.

About the wave graphic display

In Sample mode, the following screens will show a wave graphic display. This allows you to graphically view the waveform of a sample as you edit the various points (parameters). In particular, the Insert, Mixing, and Combine screen allow you to simultaneously view the waveforms of two samples.

Loop & Smoothing display / Time Stretch display / Bit Convert display
 Truncate display / Cut & Splice display / Area Erase display
 Insert display / Mixing display / Combine display



The wave graphic displays in these screens can also be viewed under magnification. Click "W.Graph" and the wave graphic display will open. To return to the previous display, click F5 Param.

* When a wave graphic display is opened, the Mode Menu switches, the Mark/Jump switch, and the Command switch cannot be used. You must first click F5 Param to return to the previous display.

The various parts of the wave graphic display are as follows.

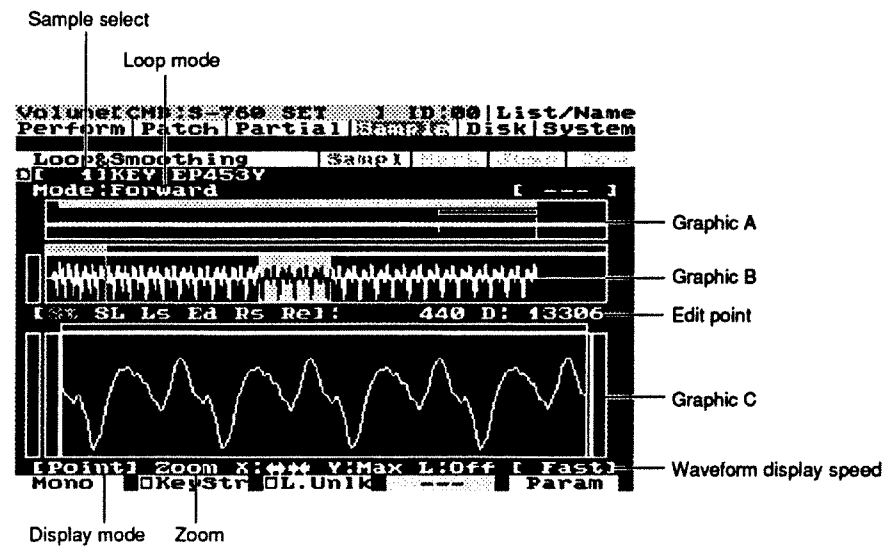

How to view the wave graphic

Graphic A

This area displays the location and range of each point (parameter) of the wave data. Here you can modify the location of each point. The contents of the wave graphic display will be different depending on the screen from which you opened it.

When opened from the Loop & Smoothing display

The upper part indicates the area in which the wave data will be read (Start point — Loop End point / Release Loop End point) and the Loop/Release Loop area. The loop area is indicated by a light blue bar. Loop areas that are rendered ineffective by the selected Loop mode (e.g., the Release loop when the Loop mode is OneShot/Forward, etc.) are indicated by a light blue solid line.

The lower part indicates the Loop Smoothing Length and the Release Loop Smoothing Length.

When opened from other displays

The graphic will show the area to which the editing command will apply, and the fade area before and after it. The area to be edited is indicated as a light blue bar. The fade areas are indicated as light blue boxes.

Moving the points in graphic A

The location of each point in graphic A can be moved by dragging it to left or right with the mouse.

Move the mouse cursor to the location of the desired point, and drag it to left or right while pressing the left mouse button.

The setting of other points or the Loop Length Lock setting will determine the range in which the point can be moved, and the loop area and length will be adjusted automatically.

Graphic B

The lower part displays the entire length of the waveform data, and allows you to make approximate settings for each point.

In this graphic you can playback samples, set the Current Point, and specify the range which will be displayed in graphic C.

*** While a sample is playing back, a moving red line will be displayed in graphic B. This line indicates the current location of playback, in a way similar to the playback head of a tape recorder. This red line is called "Current Point".**

Sample playback

To playback a sample, use the upper framed area or the vertical box located at the left side.

Place the mouse cursor in the upper framed area, and press and hold down the left mouse button to playback the sample.

If you press and hold down the left mouse button in the right part of the framed area, the sample will be played in the forward direction. If you press and hold down the left mouse button in the left part of the framed area, the sample will be played backward. At this time, the location in the framed area where you press the mouse button will determine the playback speed. The closer you are to the right or left edge of the framed area, the faster the sample will playback. If you continue pressing the mouse button and drag the mouse to left or right, the sample playback speed will change in realtime. At this time, pressing the right mouse button will halve the speed. In the upper right of the screen, the playback direction and playback speed are indicated by an arrow and a [%] display.

If you click the right mouse button inside the framed area, sample playback will be continued. When you release the right mouse button the sample will continue to be played back. At this time, if you drag the mouse while holding the left mouse button, the playback speed will change in realtime.

If you click the right mouse button once again, sample playback will be canceled.

By placing the mouse cursor in the vertical box located at the left side, and holding down the left mouse button, you can playback the sample as specified by the Key On Mode settings (Advanced Operation p.3-49).

Depending on where in the vertical box you press the left mouse button, the sample playback speed will change in four stages. From the top of the box, the playback speed will be [100%], [50%], [25%] and [12%]. If you click the right mouse button in the vertical box, sample playback will be continued. When you release the right mouse button sample playback will be continued.

Moving the current point and specifying the display area for graphic C

The lower framed area displays the waveform for the entire wave data.

If you click the left mouse button in this area, the current point will move to that location.

If you hold down the right mouse button in this area and drag to the right, the specified area will be displayed in greater detail in graphic C.

- * In the Loop & Smoothing display, the display area of graphic C will be set automatically and cannot be changed if the display mode is [Loop] or [RLoop].

Edit points

The display indicates the following points.

[St]:	Start point
[SL]:	Start & Loop Start point
[Ls]:	Loop Start point
[Ed]:	Loop End point
[Rs]:	Release Loop Start point
[Re]:	Release Loop End point
[From]:	the start point of each edit area
[To]:	the end point of each edit area

If you press the left mouse button on an edit point, the value of that point will be set to the current point. Use this method when you wish to set the current point to the desired location, and then assign the current point to be the value of an edit point.

Alternatively, you can press the right mouse button on an edit point to move the current point to the location of that point. The point on which you pressed the right mouse button will be displayed in red characters, and as a green line in graphic C. To the right of the point will be displayed the parameter value and data (D) of the point currently displayed in red characters. You can make fine adjustments to each value.

- * The valid points will differ depending on the screen and the display mode.

Display mode

This sets the display mode of graphic C.

Point: The waveform area specified in graphic B will be displayed. You can scroll the displayed area using the vertical boxes (scroll switches) located at the left and right of graphic C. Pressing the left mouse button will move left, and pressing the right button will move right.

Loop: The left side will display the waveform up to the Loop End point, and the right side will display the waveform from the Loop point. Use the scroll switches to move the various points. Pressing the left mouse button will move left, and pressing the right button will move right. If the Loop mode is Alt, the waveform up to the Loop End point / Loop point and the 'folded back' (backwards) waveform will be displayed.

R-Loop: The left side will display the waveform up to the Release Loop End point, and the right side will display the waveform from the Release Loop point. Use the scroll switches to move the various points.

Graphic C

This graphic displays the area of wave data selected in graphic B or the area specified by the display mode. In this graphic you can playback the selected area of the sample, and specify the current point. You can also set the various edit points.

*** If the wave graphic display was opened from the Loop & Smoothing display, the area displayed in graphic C will depend on the display mode (Ver.2 p.4-7).**

Sample playback

You can playback the sample in the same way as explained for graphic B. Place the mouse cursor in the vertical box located at the left side, and hold down the left mouse button to playback the sample from the current point or from the beginning of the area displayed in graph C. Depending on where in the vertical box you press the left mouse button, the sample playback speed will change in four stages. From the top of the box, the playback speed will be [100%], [50%], [25%] and [12%].

Moving the current point

The point selected for edited is indicated by a green line. The waveform of the wave data is displayed in the lower frame. If you click the left mouse button inside this frame, the current point will be moved to the location you specified. If you click the right mouse button, the editing point will be set to the location you specified.

Opening the graphic from the Loop & Smoothing display

If the display mode is [Loop] or [RLoop], it is not possible to playback the sample from graphic C.

If the display mode is [Loop], the left side will display the waveform up to the Loop End point, and the right side will display the waveform from the Loop point. If the display mode is [RLoop], the left side will display the waveform up to the Release Loop End point, and the right side will display the waveform from the Release Loop point. The location for editing is determined by the edit point, and you can use the scroll switches to move the various points.

Zoom

You can zoom in or zoom out on the waveform display of graphic C. For details refer to Advanced Operation p.3-67.

Waveform display speed

You can select the speed at which the waveform will be displayed in graphics B and C.

Norm: The waveform will be displayed in detail. Display speed will be slower.
Fast: The waveform will be displayed with the data thinned out. Display speed will be faster.

How to set the waveform points (parameters)

Basic procedure

Here's an outline of the basic procedure.

1. Select a Sample.
2. Playback the Sample in graphic B, and find the approximate location of the point you wish to set.
3. Use graphic C to see a detailed display of the waveform in the vicinity of that location.
4. Find the precise location for the point.
5. Specify the location for the point.
6. Repeat steps 1-5 for each point you wish to set (e.g., Loop Start point, End point, etc.).

Select a sample

1. Move the cursor to the List/Name switch (Ver.2 p.3-4) and click the left mouse button. The sample select display will appear. Click the sample you wish to select.
You can also select a sample by moving the cursor to Select Sample and clicking the left or right mouse button.
- * For the Insert / Mixing / Combine displays, you can select 1 destination sample and 2 source samples (Advanced Operation p.3-65).

Finding the approximate location

2. Make settings for Loop Mode, Original Key, sample display speed, etc.
3. Watch the waveform display in graphic B, and move the Current Point to the approximate area of the point you want to set.
4. Use the mouse to playback the sample to check the Current Point location.

Zoom in the graphic

5. Use the right mouse button to select an area (in graphic B) of the waveform around the Current Point, so that it will be displayed in graphic C.
6. In the same way as in graphic B, playback the sample and determine the precise location of the desired point. If you zoom in the X-axis or Y-axis of the waveform display, it will be easier to find the best spot. If the waveform display has been zoomed in, the current point may fall outside the displayed area. If so, use the scroll switches located at the left and right to move the area displayed in graphic C.
7. When you have determined the precise spot for the point, click on the vertical box located at the left to playback the sample and check the point. If the location of the point is correct, proceed to the next step. If not, try step 6 once again.

Set the location of the edit point

8. When you have set the Current Point to the desired location, click the left mouse button on the edit point you wish to set. The selected edit point will be set to the value of the Current Point.
- * If you mistakenly click the right mouse button on the edit point you wish to set, the Current Point will be moved to the value of the edit point, and you will have to go through the whole procedure again. Be sure to click the left mouse button.
- * You can check the status of the newly specified point in graphic A.

Repeat the above procedure to make settings for each of the edit points.

MEMO



Chapter 5

Sound data compatibility between Ver.1 and Ver.2

Sound data compatibility between Ver.1 and Ver.2

Compared with S-760 Ver.1, the parameters added/modified in Ver.2 are as follows. "Loaded value" refers to the parameter value when S-760 Ver.1 sound data is loaded into Ver.2. Other parameters are the same as Ver.1.

- * Parameters marked by an asterisk "*" are also found on the S-760 Ver. 1, but the range of settings has been extended.

Sound	Parameter	Loaded value
Performance	Part Solo (Parts 1-32)	Off
	Part Mute (Parts 1-32)	Off
	* Pan Receive Switch (Ch.1-16)	(see note)
Patch	One Shot Mode	Off
	Aftertouch LFO Pan Depth	0
	Modulation LFO Pan Depth	0
	Control Change LFO Pan Depth	0
Partial	* Sample Pan	the S-760 Ver.1 value
	LFO Pan Modulation Depth	0

(Note) The S-760 Ver.1 had the same parameter, but the range of settings has been expanded. When Ver.1 sound data is loaded into Ver.2, a Ver.1 setting of [o] will be loaded into Ver.2 as [D]. A Ver.1 setting of [-] will be loaded as [-].

- * If sound data created in Ver.2 is loaded into an S-760 that was started up with Ver.1, the "Pan Receive Switch" and "Sample Pan" settings will be the same as when SP-700 sound data is loaded into an S-760 that was started up with Ver.1. Refer to "Compared to the SP-700" (Advanced Operation p.2-3). Parameters added in Ver.2 are ignored by Ver.1.



Chapter 6

Appendix

List of parameters added/modified in Ver.2

System parameters

Group	Parameter	Display	Values	Page
System Parameter	Continuous Pan	Continuous Pan	Off, On	System PRM
	Analog Input Monitor	Analog Input Monitor	Off, 1 — 127	
Mark Set	Mark Set List (LCD:Up to 20 CRT:Up to 20)	[01] — [20]	Page Name	Mark
Name History	Name History List (Up to 20)	Name	Name	ASCII Keyboard

Performance parameters

Parameter	Display	Values	Initial Values	Page
Part Solo	S	Off, On	Off	Perform Play
Part Mute	M	Off, On	Off	
Pan Reception	Pan	-, C, D	C	Perform MIDI Filter

Patch parameters

Parameter	Display	Values	Initial Values	Page
1 Shot Mode	1Shot Mode	Off, On	Off	Patch Common
Aftertouch LFO Pan Depth	A.T, LFO-PAN Depth	-63 — 63	0	Patch Control
Modulation LFO Pan Depth	Mod, LFO-PAN Depth	-63 — 63	0	
Control Change LFO Pan Depth	Ctrl, LFO-PAN Depth	-63 — 63	0	

Partial parameters

Parameter	Display	Values	Initial Values	Page
Sample Pan	Pan	L32 — 0 — R32, Rnd, KF+, KF-, LF+, LF-, Alt	0	Prt SMT
LFO Pan Modulation Depth	PAN Depth	-63 — 63	0	Prt LFO

Cleaning the mouse

If the ball becomes dirty, remove the bottom cover as shown below, and use a soft cloth to wipe the ball and the inside of the mouse. (Do not attempt to disassemble any part of the mouse except as described below.)

1. Press on areas A and A' of the bottom cover, and rotate it counterclockwise so that 'Δ' is aligned with 'O'.
2. Turn the mouse over, remove the bottom cover and the ball, and wipe them off. After wiping them clean, turn the mouse over and replace the ball.
3. Replace the bottom cover so that 'Δ' is aligned with 'O'. Press on areas A and A' of the bottom cover, and rotate it clockwise so that 'Δ' is aligned with 'C'.

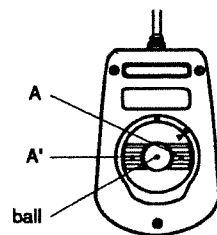

Troubleshooting

This section lists some possible problems that may occur when using the S-760 and OP-760-1 and gives appropriate measures to be taken. Refer to "TROUBLESHOOTING" (Advanced Operation p.7-8) together with this section.

The S-760 LCD screen does not appear

In the System Parameter display page 2, is the Controller setting set to a value other than [Panel+LCD] (Ver.2 p.3-2)?

During startup, the Controller setting can be verified in the LCD or the CRT display.

Cannot operate the S-760 using the mouse or RC-100

In the System Parameter display page 2, is the Controller setting set to a value other than [Mouse+CRT] or [RC100+CRT] (Ver.2 p.3-2)?

If so, the mouse or RC-100 cannot be used.

* **Before you use the RC-100, be sure to press the reset button on its rear panel.**

Is the rear panel EXT CTRL connector correctly connected?

Refer to "Connecting the mouse/RC-100" (Ver.2 p.2-4) and check connections.

Is the mouse ball dirty?

If the mouse ball becomes dirty, the mouse will not move smoothly. Refer to "Cleaning the mouse" (Ver.2 p.6-3) and clean the ball.

Was a sound being sampled, Smoothing or Truncate being executed, a disk drive being accessed, memory being processed, MIDI being received, or other data processing in progress?

The mouse cursor will not move while data is being processed, but this is not a malfunction.

The buttons or mouse stopped working after you changed the controller setting

You made incorrect controller settings. Refer to "If you make an incorrect selection" (Ver.2 p.3-2).

The buttons or mouse stopped working during operation

If pressing the buttons causes no change in the display, the system program may have crashed. Turn the power off, and then on again. In this case, all unsaved data you had been editing will be lost.

Specifications

OP-760-1 Power Sampling Expansion

Connectors

Digital I/O (COAXIAL)

Inputs :1

Outputs :2

Display output

Digital RGB :1

Video out :1

S-video out :1

External control connector :1

Accessories

Owner's manual :1

S-760 user leaflet :1

System disk (Ver.2) :1

Mouse (MU-1) :1

*** In the interest of product development, the specifications and/or appearance of this unit are subject to change without prior notice.**



This product complies with the requirements of European Directive 89/336/EEC.

For Europe

Information

When you need repair service, call your local Roland Service Station or the authorized Roland distributor in your country as shown below.

ARGENTINA

Instrumentos Musicales S.A.
Florida 638
(1005) Buenos Aires
ARGENTINA
TEL: (01) 394 4029

BRAZIL

Roland Brasil Ltda.
R. Coronel Octaviano da Silveira
203 05522-010
Sao Paulo BRAZIL
TEL: (011) 843 9377

CANADA

Roland Canada Music Ltd.
(Head Office)
5480 Parkwood Way Richmond
B. C., V6V 2M4 CANADA
TEL: (0604) 270 6626

Roland Canada Music Ltd.
(Toronto Office)
Unit 2, 109 Woodbine Downs
Blvd, Etobicoke, ON
M9W 6Y1 CANADA
TEL: (0416) 213 9707

MEXICO

Casa Veerkamp, s.a. de c.v.
Av. Toluca No. 323 Col. Olivar de
los Padres 01780 Mexico D.F.
MEXICO
TEL: (525) 668 04 80

**La Casa Wagner de
Guadalajara s.a. de c.v.**
Av. Corona No. 202 S.J.
Guadalajara, Jalisco Mexico
C.P.44100 MEXICO
TEL: (03) 613 1414

PANAMA

Productos Superiores, S.A.
Apartado 655 - Panama 1
REP. DE PANAMA
TEL: 26 3322

U. S. A.

Roland Corporation U.S.
7200 Dominion Circle
Los Angeles, CA. 90040-3696,
U. S. A.
TEL: (0213) 685 5141

VENEZUELA

Musiland Digital C.A.
Av. Francisco de Miranda,
Centro Parque de Cristal, Nivel
C2 Local 20 Caracas
VENEZUELA
TEL: (02) 285 9218

AUSTRALIA

**Roland Corporation
Australia Pty. Ltd.**
38 Campbell Avenue
Dee Why West. NSW 2099
AUSTRALIA
TEL: (02) 982 8266

NEW ZEALAND

Roland Corporation (NZ) Ltd.
97 Mt. Eden Road, Mt. Eden,
Auckland 3, NEW ZEALAND
TEL: (09) 3098 715

HONG KONG

Tom Lee Music Co., Ltd.
Service Division
22-32 Pun Shan Street, Tsuen
Wan, New Territories,
HONG KONG
TEL: 2415 0911

INDONESIA

PT Galestra Inti
Kompleks Perkantoran
Duta Merlin Blok E No.6-7
Jl. Gajah Mada No.3-5,
Jakarta 10130,
INDONESIA
TEL: (021) 6335416

KOREA

**Cosmos Corporation
Service Station**
261 2nd Floor Nak-Won Arcade
Jong-Ro ku, Seoul, KOREA
TEL: (02) 742 8844

MALAYSIA

Bentley Music SDN BHD
No.142, Jalan Bukit Bintang 55100
Kuala Lumpur, MALAYSIA
TEL: (03) 2443333

PHILIPPINES

G.A. Yupangco & Co. Inc.
339 Gil J. Puyat Avenue
Makati, Metro Manila 1200,
PHILIPPINES
TEL: (02) 899 9801

SINGAPORE

Swee Lee Company
BLOCK 231, Bain Street #03-23
Bras Basah Complex,
SINGAPORE 0718
TEL: 3367986

CRISTOFORI MUSIC PTE LTD

335, Joo Chiat Road SINGAPORE
1542
TEL: 3450435

TAIWAN

**Siruba Enterprise (Taiwan)
Co., LTD.**
Room. 5, 9fl. No. 112 Chung Shan
N. Road Sec.2 Taipei, TAIWAN,
R.O.C.
TEL: (02) 561 3339

THAILAND

Theera Music Co., Ltd.
330 Verg Nakorn Kasem, Soi 2,
Bangkok 10100, THAILAND
TEL: (02) 2248821

BAHRAIN

Moon Stores
Bad Al Bahrain Road,
P.O.Box 20077
State of BAHRAIN
TEL: 211 005

IRAN

TARADIS
Mir Emad Ave. No. 15, 10th street
P. O. Box 15875/4171 Teheran,
IRAN
TEL: (021) 875 6524

ISRAEL

**Halilit P. Greenspoon &
Sons Ltd.**
8 Retzif Ha'aliya Hashnya St.
Tel-Aviv-Yafo ISRAEL
TEL: (03) 6823666

JORDAN

AMMAN Trading Agency
Prince Mohammed St. P. O. Box
825 Amman 11118 JORDAN
TEL: (06) 641200

KUWAIT

Easa Husain Al-Yousifi
P.O. Box 126 Safat 13002
KUWAIT
TEL: 5719499

LEBANON

A. Chahine & Fils
P.O. Box 16-5857 Gergi Zeidan St.
Chahine Building, Achrafieh
Beirut, LEBANON
TEL: (01) 335799

OMAN

**OHI Electronics & Trading
Co. LLC**
P. O. Box 889 Muscat
Sultanate of OMAN
TEL: 706 010

QATAR

Badie Studio & Stores
P.O.Box 62,
DOHA QATAR
TEL: 423554

SAUDI ARABIA

SAF Music Center
AL-Khobar 31952, P. O. Box 1366
SAUDIARABIA
TEL: (03) 898 3311

**Abdul Latif S. Al-Ghamdi
Trading Establishment**
Middle East Commercial Center
Al-Khobar Dharan Highway
W/hamood st.
P. O. Box 3631 Al-Khobar
31952 SAUDIARABIA
TEL: (03) 898 2332

SYRIA

**Technical Light & Sound
Center**
Khaled Ebn Al Walid St.
P.O.Box 13520
Damascus - SYRIA
TEL: (011) 2235 384

TURKEY

Barkat Sanayi ve Ticaret
Siraselvier Cad. Guney Ishani No.
86/6 Taksim, Istanbul TURKEY
TEL: (0212) 2499324

U.A.E

**Zak Electronics & Musical
Instruments Co.**
Zabeel Road, Al Sherooq Bldg.,
No. 14, Grand Floor DUBAI
U.A.E.
P.O. Box 8050DUBAI, U.A.E
TEL: (04) 360715

EGYPT

Al Fanny Trading Office
9, Ebn Hagar Ai Askalany Street,
Ard El Golf, Heliopolis, Cairo,
11341 EGYPT
TEL: (02) 4171828
(02) 4185531

MAURITIUS

Philanne Music Center
4th, Floor Noll, Happy World
House Sir William Newton Street
Port Luis MAURITIUS
TEL: 242 2986

REUNION

FO - YAM Marcel
25 Rue Jules MermanZL
Chaudron - BP79 97491
Ste Clotilde REUNION
TEL: 28 29 16

SOUTH AFRICA

**That Other Music Shop
(PTY) Ltd.**
11 Melle Street (Cnr Melle and
Juta Street)
Braamfontein 2001
Republic of SOUTH AFRICA
TEL: (011) 403 4105

Paul Bothner (PTY) Ltd.
17 Werdmuller Centre Claremont
7700
Republic of SOUTH AFRICA
TEL: (021) 64 4030

AUSTRIA

E. Dematte & Co.
Neu-Rum Siemens-Strasse 4
A-6040 Innsbruck P.O.Box 83
AUSTRIA
TEL: (0512) 26 44 260

BELGIUM/HOLLAND/ LUXEMBOURG

Roland Benelux N. V.
Houtstraat 1 B-2260 Oevel-
Westerio BELGIUM
TEL: (014) 575811

BELORUSSIA

TUSHE
UL. Mogilovskaja 4/4/145
220001 MINSK
TEL: (0172) 252-059

CYPRUS

Radex Sound Equipment Ltd.
17 Diagorou St., P.O.Box 2046,
Nicosia CYPRUS
TEL: (02) 453 426
(02) 466 423

DENMARK

Roland Scandinavia A/S
Langebrogade 6 Post Box 1937
DK-1023 Copenhagen K.
DENMARK
TEL: 32 95 3111

FRANCE

Guillard Musiques Roland
ZAC de Rosarge Les Echets 01700
MIRIBEL FRANCE
TEL: 7226 5060

**Guillard Musiques Roland
(Paris Office)**
1923 rue Léon Geoffroy 94400
VITRY-SUR-SEINE FRANCE
TEL: (1) 4680 86 62

FINLAND

**Roland Scandinavia As,
Filial Finland**
Lauttasaarentie 54 B
Fin-00201 Helsinki, FINLAND
P. O. Box No. 109
TEL: (0) 682 4020

GERMANY

**Roland Elektronische
Musikinstrumente
Handelsgesellschaft mbH.**
Oststrasse 96, 22844 Norderstedt,
GERMANY
TEL: (040) 52 60090

GREECE

V. Dimitriadis & Co. Ltd.
20, Alexandros St. & Bouboulinas
54 St. 106 82 Athens, GREECE
TEL: (01) 8232415

HUNGARY

Intermusica Ltd.
Warehouse Area 'DEPO' Pl.83
H-2046 Torokbalint, HUNGARY
TEL: (23) 338 041

IRELAND

**The Dublin Service Centre
Audio Maintenance Limited**
11 Brunswick Place Dublin 2
Republic of IRELAND
TEL: (01) 677322

ITALY

Roland Italy S. p. A.
Viale delle Industrie, 8
20020 Arese Milano, ITALY
TEL: (02) 93581311

NORWAY

**Roland Scandinavia Avd.
Kontor Norge**
Lilleakerveien 2 Postboks 95
Lilleaker N-0216 Oslo
NORWAY
TEL: 273 0074

POLAND

P. P. H. Brzostowicz Marian
UL. Blokowa 32, 03624 Warszawa
POLAND
TEL: (022) 679 44 19

PORTUGAL

**Caius - Tecnologias Audio e
Musica, Lda.**
Rue de Catarina 131
4000 Porto, PORTUGAL
TEL: (02) 38 4456

RUSSIA

PETROSHOP Ltd.
11 Sayanskaya Street Moscow
11531, RUSSIA
TEL: 095 901 0892

SPAIN

**Roland Electronics
de España, S. A.**
Calle Bolivia 239 08020 Barcelona,
SPAIN
TEL: (93) 308 1000

SWEDEN

Roland Scandinavia A/S
Danvik Center 28 A, 2 tr.
S-131 30 Nacka SWEDEN
TEL: (08) 702 0020

SWITZERLAND

**Roland (Switzerland) AG
Musitronic AG**
Gerberstrasse 5, CH-4410 Liestal,
SWITZERLAND
TEL: (061) 921 1615

UKRAINE

TIC-TAC
Mira Str. 19/108
P.O.Box 180
295400 Munkachevo, UKRAINE
TEL: (03131) 414-40

UNITED KINGDOM

**Roland (U.K.) Ltd., Swansea
Office**
Atlantic Close, Swansea
Enterprise Park SWANSEA
West Glamorgan SA7 9FJ,
UNITED KINGDOM
TEL: (01792) 702701

 Roland®

00125878

UPC

00125878



:099:

Roland