

**EDIROL**

# Hi-SPEED USB Audio Capture

**10 IN/10 OUT 24 bit 192 kHz**

# UA-101

## OWNER'S MANUAL

Before using this unit, carefully read the sections entitled: "USING THE UNIT SAFELY" and "IMPORTANT NOTES" (p. 3–p. 6). These sections provide important information concerning the proper operation of the unit. Additionally, in order to feel assured that you have gained a good grasp of every feature provided by your new unit, OWNER'S MANUAL should be read in its entirety. The manual should be saved and kept on hand as a convenient reference.

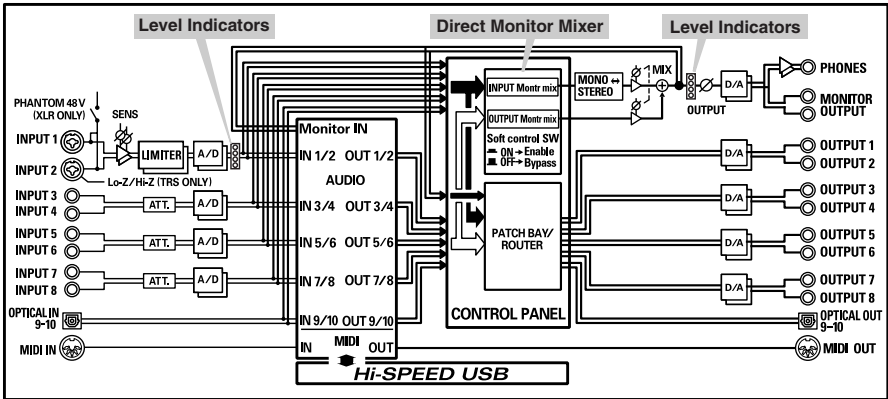

Copyright © 2005 ROLAND CORPORATION

All rights reserved. No part of this publication may be reproduced in any form without the written permission of ROLAND CORPORATION.

For the U.K.

**IMPORTANT:** THE WIRES IN THIS MAINS LEAD ARE COLOURED IN ACCORDANCE WITH THE FOLLOWING CODE.

BLUE: NEUTRAL  
BROWN: LIVE

As the colours of the wires in the mains lead of this apparatus may not correspond with the coloured markings identifying the terminals in your plug, proceed as follows:

The wire which is coloured BLUE must be connected to the terminal which is marked with the letter N or coloured BLACK.  
The wire which is coloured BROWN must be connected to the terminal which is marked with the letter L or coloured RED.  
Under no circumstances must either of the above wires be connected to the earth terminal of a three pin plug.

For EU Countries



This product complies with the requirements of European Directive 89/336/EEC.

For the USA

## FEDERAL COMMUNICATIONS COMMISSION RADIO FREQUENCY INTERFERENCE STATEMENT

This equipment has been tested and found to comply with the limits for a Class B digital device, pursuant to Part 15 of the FCC Rules. These limits are designed to provide reasonable protection against harmful interference in a residential installation. This equipment generates, uses, and can radiate radio frequency energy and, if not installed and used in accordance with the instructions, may cause harmful interference to radio communications. However, there is no guarantee that interference will not occur in a particular installation. If this equipment does cause harmful interference to radio or television reception, which can be determined by turning the equipment off and on, the user is encouraged to try to correct the interference by one or more of the following measures:

- Reorient or relocate the receiving antenna.
- Increase the separation between the equipment and receiver.
- Connect the equipment into an outlet on a circuit different from that to which the receiver is connected.
- Consult the dealer or an experienced radio/TV technician for help.

This device complies with Part 15 of the FCC Rules. Operation is subject to the following two conditions:

- (1) This device may not cause harmful interference, and
- (2) This device must accept any interference received, including interference that may cause undesired operation.

Unauthorized changes or modification to this system can void the users authority to operate this equipment.  
This equipment requires shielded interface cables in order to meet FCC class B Limit.

For Canada

## NOTICE

This Class B digital apparatus meets all requirements of the Canadian Interference-Causing Equipment Regulations.

## AVIS

Cet appareil numérique de la classe B respecte toutes les exigences du Règlement sur le matériel brouilleur du Canada.

For the USA



## DECLARATION OF CONFORMITY Compliance Information Statement

Model Name : UA-101  
Type of Equipment : USB Audio Interface  
Responsible Party : Roland Corporation U.S.  
Address : 5100 S. Eastern Avenue Los Angeles, CA 90040-2938  
Telephone : (323) 890 3700







# USING THE UNIT SAFELY

## INSTRUCTIONS FOR THE PREVENTION OF FIRE, ELECTRIC SHOCK, OR INJURY TO PERSONS

About  WARNING and  CAUTION Notices







 <b>WARNING</b>	Used for instructions intended to alert the user to the risk of death or severe injury should the unit be used improperly.
 <b>CAUTION</b>	Used for instructions intended to alert the user to the risk of injury or material damage should the unit be used improperly. * Material damage refers to damage or other adverse effects caused with respect to the home and all its furnishings, as well to domestic animals or pets.

About the Symbols





	The  symbol alerts the user to important instructions or warnings. The specific meaning of the symbol is determined by the design contained within the triangle. In the case of the symbol at left, it is used for general cautions, warnings, or alerts to danger.
	The  symbol alerts the user to items that must never be carried out (are forbidden). The specific thing that must not be done is indicated by the design contained within the circle. In the case of the symbol at left, it means that the unit must never be disassembled.
	The  symbol alerts the user to things that must be carried out. The specific thing that must be done is indicated by the design contained within the circle. In the case of the symbol at left, it means that the power-cord plug must be unplugged from the outlet.

### ALWAYS OBSERVE THE FOLLOWING

#### **WARNING**

- Before using this unit, make sure to read the instructions below, and the Owner's Manual. 
- Do not open (or modify in any way) the unit or its AC adaptor. 
- Do not attempt to repair the unit, or replace parts within it (except when this manual provides specific instructions directing you to do so). Refer all servicing to your retailer, the nearest Roland Service Center, or an authorized Roland distributor, as listed on the "Information" page. 
- Never use or store the unit in places that are:
  - Subject to temperature extremes (e.g., direct sunlight in an enclosed vehicle, near a heating duct, on top of heat-generating equipment); or are
  - Damp (e.g., baths, washrooms, on wet floors); or are
  - Humid; or are
  - Exposed to rain; or are
  - Dusty; or are
  - Subject to high levels of vibration. 
- Make sure you always have the unit placed so it is level and sure to remain stable. Never place it on stands that could wobble, or on inclined surfaces. 
- Be sure to use only the AC adaptor supplied with the unit. Also, make sure the line voltage at the installation matches the input voltage specified on the AC adaptor's body. Other AC adaptors may use a different polarity, or be designed for a different voltage, so their use could result in damage, malfunction, or electric shock. 

#### **WARNING**

- Use only the attached power-supply cord. Also, the supplied power cord must not be used with any other device. 
- Do not excessively twist or bend the power cord, nor place heavy objects on it. Doing so can damage the cord, producing severed elements and short circuits. Damaged cords are fire and shock hazards! 
- This unit, either alone or in combination with an amplifier and headphones or speakers, may be capable of producing sound levels that could cause permanent hearing loss. Do not operate for a long period of time at a high volume level, or at a level that is uncomfortable. If you experience any hearing loss or ringing in the ears, you should immediately stop using the unit, and consult an audiologist. 
- Do not allow any objects (e.g., flammable material, coins, pins); or liquids of any kind (water, soft drinks, etc.) to penetrate the unit. 
- Immediately turn the power off, remove the AC adaptor from the outlet, and request servicing by your retailer, the nearest Roland Service Center, or an authorized Roland distributor, as listed on the "Information" page when:
  - The AC adaptor, the power-supply cord, or the plug has been damaged; or
  - If smoke or unusual odor occurs
  - Objects have fallen into, or liquid has been spilled onto the unit; or
  - The unit has been exposed to rain (or otherwise has become wet); or
  - The unit does not appear to operate normally or exhibits a marked change in performance. 

## **WARNING**

- In households with small children, an adult should provide supervision until the child is capable of following all the rules essential for the safe operation of the unit. 

---

- Protect the unit from strong impact. (Do not drop it!) 

---

- Do not force the unit's power-supply cord to share an outlet with an unreasonable number of other devices. Be especially careful when using extension cords—the total power used by all devices you have connected to the extension cord's outlet must never exceed the power rating (watts/amperes) for the extension cord. Excessive loads can cause the insulation on the cord to heat up and eventually melt through. 

---

- Before using the unit in a foreign country, consult with your retailer, the nearest Roland Service Center, or an authorized Roland distributor, as listed on the "Information" page. 

---

- **DO NOT** play a CD-ROM disc on a conventional audio CD player. The resulting sound may be of a level that could cause permanent hearing loss. Damage to speakers or other system components may result. 

## **CAUTION**

- The unit and the AC adaptor should be located so their location or position does not interfere with their proper ventilation. 

---

- Always grasp only the plug on the AC adaptor cord when plugging into, or unplugging from, an outlet or this unit. 

---

- At regular intervals, you should unplug the AC adaptor and clean it by using a dry cloth to wipe all dust and other accumulations away from its prongs. Also, disconnect the power plug from the power outlet whenever the unit is to remain unused for an extended period of time. Any accumulation of dust between the power plug and the power outlet can result in poor insulation and lead to fire. 

---

- Try to prevent cords and cables from becoming entangled. Also, all cords and cables should be placed so they are out of the reach of children. 

---

- Never climb on top of, nor place heavy objects on the unit. 

---

- Never handle the AC adaptor or its plugs with wet hands when plugging into, or unplugging from, an outlet or this unit. 

---

- Before moving the unit, disconnect the AC adaptor and all cords coming from external devices. 

---

- Before cleaning the unit, turn off the power and unplug the AC adaptor from the outlet. 

---

- Whenever you suspect the possibility of lightning in your area, disconnect the AC adaptor from the outlet. 

---

- Should you remove the grounding terminal screw, keep them in a safe place out of children's reach, so there is no chance of them being swallowed accidentally. 

---

- Always turn the phantom power off when connecting any device other than condenser microphones that require phantom power. You risk causing damage if you mistakenly supply phantom power to dynamic microphones, audio playback devices, or other devices that don't require such power. Be sure to check the specifications of any microphone you intend to use by referring to the manual that came with it. 

(This instrument's phantom power: DC 48V, 20mA Max)

# IMPORTANT NOTES

In addition to the items listed under “USING THE UNIT SAFELY” on page 3, please read and observe the following:

## Power Supply

- Do not connect this unit to same electrical outlet that is being used by an electrical appliance that is controlled by an inverter (such as a refrigerator, washing machine, microwave oven, or air conditioner), or that contains a motor. Depending on the way in which the electrical appliance is used, power supply noise may cause this unit to malfunction or may produce audible noise. If it is not practical to use a separate electrical outlet, connect a power supply noise filter between this unit and the electrical outlet.
- The AC adaptor will begin to generate heat after long hours of consecutive use. This is normal, and is not a cause for concern.
- Before connecting this unit to other devices, turn off the power to all units. This will help prevent malfunctions and/or damage to speakers or other devices.

## Placement

- Using the unit near power amplifiers (or other equipment containing large power transformers) may induce hum. To alleviate the problem, change the orientation of this unit; or move it farther away from the source of interference.
- This device may interfere with radio and television reception. Do not use this device in the vicinity of such receivers.
- Noise may be produced if wireless communications devices, such as cell phones, are operated in the vicinity of this unit. Such noise could occur when receiving or initiating a call, or while conversing. Should you experience such problems, you should relocate such wireless devices so they are at a greater distance from this unit, or switch them off.

- Do not expose the unit to direct sunlight, place it near devices that radiate heat, leave it inside an enclosed vehicle, or otherwise subject it to temperature extremes. Excessive heat can deform or discolor the unit.
- When moved from one location to another where the temperature and/or humidity is very different, water droplets (condensation) may form inside the unit. Damage or malfunction may result if you attempt to use the unit in this condition. Therefore, before using the unit, you must allow it to stand for several hours, until the condensation has completely evaporated.

## Maintenance

- For everyday cleaning wipe the unit with a soft, dry cloth or one that has been slightly dampened with water. To remove stubborn dirt, use a cloth impregnated with a mild, non-abrasive detergent. Afterwards, be sure to wipe the unit thoroughly with a soft, dry cloth.
- Never use benzine, thinners, alcohol or solvents of any kind, to avoid the possibility of discoloration and/or deformation.

## Repairs and Data

- Please be aware that all data contained in the unit’s memory may be lost when the unit is sent for repairs. Important data should always be written down on paper. During repairs, due care is taken to avoid the loss of data. However, in certain cases (such as when circuitry related to memory itself is out of order), we regret that it may not be possible to restore the data, and Roland assumes no liability concerning such loss of data.

## Additional Precautions

- Please be aware that the contents of memory can be irretrievably lost as a result of a malfunction, or the improper operation of the unit. To protect yourself against the risk of losing important data, we recommend that you periodically write down important data you have stored in the unit's memory on paper.
- Unfortunately, it may be impossible to restore the contents of data that was stored in the unit's memory once it has been lost. Roland Corporation assumes no liability concerning such loss of data.
- Use a reasonable amount of care when using the unit's buttons, sliders, or other controls; and when using its jacks and connectors. Rough handling can lead to malfunctions.
- When connecting / disconnecting all cables, grasp the connector itself—never pull on the cable. This way you will avoid causing shorts, or damage to the cable's internal elements.
- To avoid disturbing your neighbors, try to keep the unit's volume at reasonable levels. You may prefer to use headphones, so you do not need to be concerned about those around you (especially when it is late at night).
- When you need to transport the unit, package it in the box (including padding) that it came in, if possible. Otherwise, you will need to use equivalent packaging materials.
- Use a cable from Roland to make the connection. If using some other make of connection cable, please note the following precautions.

- Some connection cables contain resistors. Do not use cables that incorporate resistors for connecting to this unit. The use of such cables can cause the sound level to be extremely low, or impossible to hear. For information on cable specifications, contact the manufacturer of the cable.

## Handling CD-ROMs

- Avoid touching or scratching the shiny underside (encoded surface) of the disc. Damaged or dirty CD-ROM discs may not be read properly. Keep your discs clean using a commercially available CD cleaner.

## Copyright

- When exchanging audio signals through a digital connection with an external instrument, this unit can perform recording without being subject to the restrictions of the Serial Copy Management System (SCMS). This is because the unit is intended solely for musical production, and is designed not to be subject to restrictions as long as it is used to record works (such as your own compositions) that do not infringe on the copyrights of others. (SCMS is a feature that prohibits second-generation and later copying through a digital connection. It is built into MD recorders and other consumer digital-audio equipment as a copyright-protection feature.)
- Do not use this unit for purposes that could infringe on a copyright held by a third party. We assume no responsibility whatsoever with regard to any infringements of third-party copyrights arising through your use of this unit.

\* Microsoft and Windows are registered trademarks of Microsoft Corporation.

\* The screen shots in this document are used in compliance with the guidelines of the Microsoft Corporation.

\* Windows<sup>®</sup> is known officially as: "Microsoft<sup>®</sup> Windows<sup>®</sup> operating system."

\* Apple and Macintosh are registered trademarks of Apple Computer, Inc.

\* Mac OS is a trademark of Apple Computer, Inc.

\* All product names mentioned in this document are trademarks or registered trademarks of their respective owners.

# Contents

<b>Contents of the package .....</b>	<b>8</b>
<b>Front and rear panel.....</b>	<b>9</b>
Front panel.....	9
Rear panel .....	13
<b>Installing the driver .....</b>	<b>16</b>
Giving priority to Background Services .....	21
Driver settings .....	22
<b>Basic connections and settings .....</b>	<b>27</b>
Basic connections .....	27
Recording a mic or guitar .....	28
Recording a digital signal .....	30
Connecting various equipment .....	31
5.1 channel monitoring .....	32
<b>Software settings.....</b>	<b>33</b>
SONAR 4.....	33
Cubase SX .....	36
<b>Various settings .....</b>	<b>37</b>
Internal blocks of the UA-101 .....	37
UA-101 Control Panel .....	38
Adjusting the audio latency .....	41
Using Separated ports.....	42
Minimize the ASIO buffer size .....	43
Using ASIO Direct Monitor.....	44
<b>System settings.....</b>	<b>45</b>
Restoring the factory settings (Factory Reset) .....	45
<b>Troubleshooting.....</b>	<b>46</b>
Driver-related problems (Windows).....	46
Can't record or play back audio or MIDI.....	48
No sound.....	48
Noise or pops are heard when recording/playing on your computer.....	52
Noise or distortion occurs when the UA-101 is not connected to your computer .....	56
The sound is too weak.....	56
Others .....	58
Deleting the driver.....	59
<b>Main specifications .....</b>	<b>60</b>
<b>Index.....</b>	<b>62</b>

# Contents of the package

## ■ UA-101

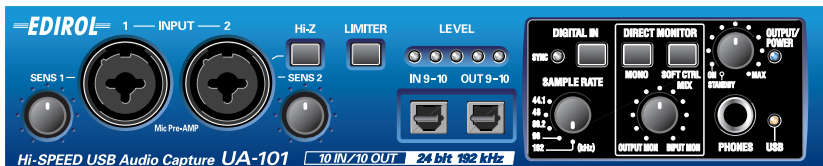

## ■ AC adaptor

This is the dedicated AC adaptor for the UA-101. Use only the supplied AC adaptor.

## ■ USB cables

Use one of these cables to connect the UA-101 to the USB connector of your computer.

\* *Use only the USB cables. If the supplied USB cable becomes damaged or lost and you need a replacement, please contact the nearest Roland Service Center, or an authorized Roland distributor, as listed on the "Information" page.*

## ■ Owner's manual

This is the manual you are reading. Please keep it at hand for reference.

## ■ CD-ROM

This contains Windows drivers for the UA-101 and demo songs.

\* *Avoid touching or scratching the shiny underside (encoded surface) of the disc. Damaged or dirty CD-ROM discs may not be read properly. Keep your discs clean using a commercially available CD cleaner.*

## ⚠ CAUTION

Do not play back the CD-ROM in a conventional audio CD player. Doing so may produce high-volume sound that can damage your hearing and/or speakers.





# Front and rear panel

## Front panel

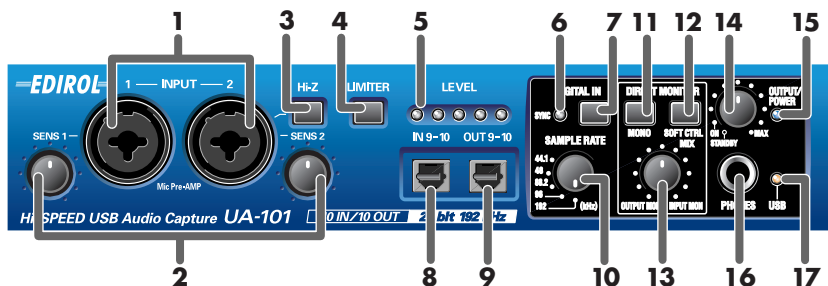

### 1. Combo input jacks

These are analog audio signal input jacks with mic preamps. Since they can accommodate either XLR type or phone type plugs, you can use the type of connector most suitable for your equipment. You may connect either balanced or unbalanced devices. The gain setting will differ depending on whether you use the XLR type or the phone type connection.

**XLR type:** -50– -10 dBu

**Phone type:** -36– +4 dBu

Use the XLR type connection if you're connecting a mic, and the phone type connection if you're connecting other equipment.

The XLR type connection can provide 48 V phantom power, allowing you to connect condenser mics that require a phantom power supply. In this case, turn on **phantom power switch (20)** on the rear panel.

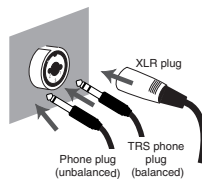

\* This instrument is equipped with balanced (XLR/TRS) type input jacks. Wiring diagrams for these jacks are shown on the right. Make connections after first checking the wiring diagrams of other equipment you intend to connect.

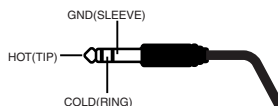

### 2. Input sensitivity knobs

These knobs adjust the input level of the signals received by the front panel **combo input jacks (1)**.

### 3. Input impedance select switch

Use this switch to select either high impedance (Hi-Z) or low impedance (Lo-Z) as appropriate for the device that's connected to the phone type input jack for **INPUT 2**. Select the high impedance (Hi-Z) setting if you've connected a guitar or bass, and select the low impedance (Lo-Z) setting if you've connected any other type of device.

\* The **INPUT 1 combo input jack** is fixed at low impedance (Lo-Z).

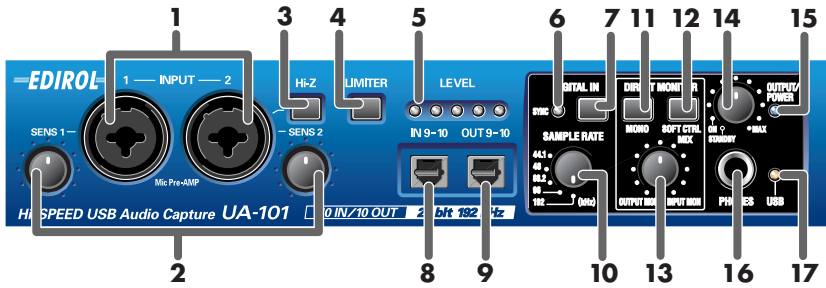

## 4. Limiter switch

This turns the UA-101's hardware limiter on/off.

Even if a high-volume audio signal is suddenly received at the **combo input jacks (1)**, this limiter will apply mild compression to prevent clipping noise from occurring before the AD converter.

\* *Clipping noise will occur if the input exceeds the capacity of the limiter.*

## 5. Input/output level indicators

These LEDs will light according to the level of the input signals at the **combo input jacks (1)** and the monitor output signals (immediately before the monitor volume). (Refer to the block diagram → front cover)

When signals are being input from the **combo input jacks (1)**, these LEDs function as input level indicators. If there is no input signal for a time, the LEDs will switch to functioning as monitor output indicators.

When functioning as input level indicators	The LEDs will light red at a level immediately before distortion occurs (-6 dB). Use the <b>input sensitivity knobs (2)</b> to adjust the input level so that the red LEDs do not light.
When functioning as monitor output level indicators	The LEDs will light red when the sound being output to the monitor output jacks reaches a level immediately before distortion (0 dB). If the LEDs light red, lower the monitor output volume in the <b>UA-101 Control Panel</b> (p. 38).

## 6. Sync indicator

When the **digital input switch (7)** is on, this indicates the state of synchronization with the digital device connected to the **digital input connector (8)**.

Lit	Synchronized correctly.
Blinking	Not synchronized correctly. Make sure that the digital device is correctly connected to the digital input connector. Also make sure that the sample rate of the connected digital device matches the setting of the UA-101's <b>sample rate select switch (10)</b> .

## 7. Digital input switch

Turn this on (⏏ pressed inward) if you're recording from the digital input. This lets you synchronize the UA-101 with an external digital device connected to the **digital input connector (8)**. (External synchronization mode)

## 8. Digital input connector (optical)

Use this when you need to input a digital audio signal from a CD/MD/DAT or similar device.

A digital signal input via the **digital input connector** is identified as audio ports **EDIROL UA-101 9-10** when you're recording it into your computer.

Turn the **digital input switch (7)** on if you want to record a digital signal. The sample rate of the input signal must match the setting of the **sample rate select switch (18)**.

## 9. Digital output connector (optical)

Use this when you need to output a digital audio signal to a MD/DAT or similar digital audio device. Signals output from EDIROL UA-101 9-10, which are the audio output ports of your computer, are output from the UA-101's **digital out connector**.

## 10. Sample rate select switch

Use this to specify the sample rate at which you want to record and play back audio data. If you change the setting of this switch, you must exit all software, switch off the UA-101, then turn it back on again.

You must set this to match the sample rate of the software you're using. If you're using external synchronization mode (digital input switch turned on), the sample rate of your external device must also match this setting.

### [Limitations when using the 192 kHz setting]

- The digital input connector and digital output connector cannot be used.
- Input jacks 7/8 and output jacks 7/8 cannot be used.

## 11. STEREO/MONO select switch (Direct Monitor section)

This selects whether the input signal will be monitored in stereo (STEREO) or in monaural (MONO). If you want to use monaural, turn this switch on (  pressed inward).

For example, if you've connected a guitar only to INPUT 2, you would use the monaural (  pressed inward) setting. Even if this is set to **monaural (MONO)**, the audio signal sent via USB to your computer will be stereo.

## 12. Direct Monitor Soft Control switch (Direct Monitor Mixer section)

Turn this on (  pressed inward) if you want to control the direct monitor mixer (block diagram → front cover) using ASIO 2.0 compliant software or UA-101 Control Panel. When this switch is on, the monitor volume, pan, and on/off settings of each input jack and each output from the computer can be controlled by your software.

(refer to "UA-101 Control Panel" (p. 38))

When this switch is off, all settings of the Direct Monitor Mixer will be ignored (i.e., bypassed), allowing you to monitor the audio inputs at all input jacks and the outputs from your computer just as they are. This provides a convenient way to temporarily ignore the software settings when you need to do things such as check the connections.

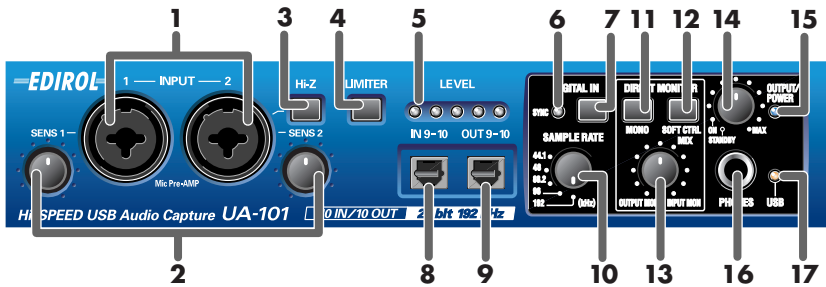

### 13. Direct monitor volume (direct monitor section)

This adjusts the monitor volume.

As you turn this toward the left (toward OUTPUT MONITOR), the level of the sound being received via the input jacks will decrease. As you turn this toward the right (toward INPUT MONITOR), the level of the sound being output from your computer will decrease. When this knob is in the center position, the level of the sound being output from your computer and the level of the sound being input via the input jacks will both be at 100%.

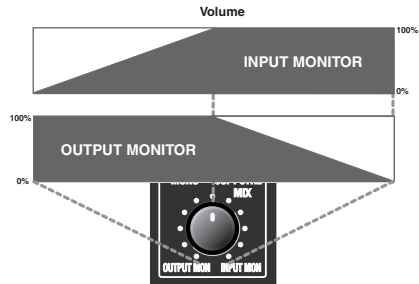

### 14. Monitor volume/Power switch

This adjusts the volume that is output from the **headphone jack (16)** and the **monitor output jacks (27)**.

This also switches the power between on (ON) and standby (STANDBY) modes.

### 15. Power indicator

This will light when the power is on.

### 16. Headphone jack

The sound received at the input jacks and the sound being output by your computer will be mixed and output from this jack. Use the **direct monitor volume knob (13)** to adjust the balance between input and output.

Sound will still be output from the rear panel **monitor output jacks (27)** even if headphones are connected.

### 17. USB indicator

This will light when you connect the UA-101 to your computer via a USB cable.

<b>Lit red</b>	The UA-101 is correctly recognized by your computer in Hi-Speed USB mode (p. 14)
<b>Lit green</b>	The UA-101 is correctly recognized by your computer in Full-Speed USB mode (p. 14)

\* If the USB indicator is blinking, the UA-101 has not been recognized correctly.

## Rear panel

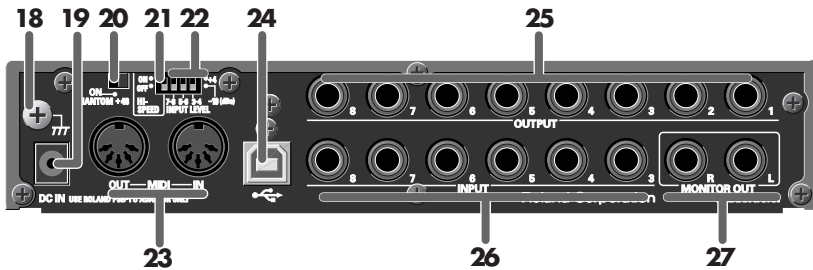

### 18. Grounding terminal

Depending on the circumstances of a particular setup, you may experience a discomforting sensation, or perceive that the surface feels gritty to the touch when you touch this device, microphones connected to it, or the metal portions of other objects, such as guitars. This is due to an infinitesimal electrical charge, which is absolutely harmless. However, if you are concerned about this, connect the ground terminal (see figure) with an external ground. When the unit is grounded, a slight hum may occur, depending on the particulars of your installation. If you are unsure of the connection method, contact the nearest Roland Service Center, or an authorized Roland distributor, as listed on the “Information” page.

#### Unsuitable places for connection

- Water pipes (may result in shock or electrocution)
- Gas pipes (may result in fire or explosion)
- Telephone-line ground or lightning rod (may be dangerous in the event of lightning)

### 19. AC adaptor jack

Connect the included AC adaptor to this jack.

\* *Do not use anything other than the included AC adaptor; doing so will cause malfunctions.*

### 20. Phantom power switch

This is an on/off switch for the phantom power supplied to the XLR connectors of the **combo input jacks (1)** on the front panel.

\* *You must leave this switch in the Off setting (toward the right) unless condenser mics requiring a phantom power supply are connected to the XLR type jacks. Malfunctions will occur if phantom power is supplied to dynamic mics or audio playback devices. For details on the requirements of your mic, refer to the owner’s manual for the mic you’re using.  
(The UA-101’s phantom power supply is DC 48V, maximum of 20 mA.)*

## 21. Hi-Speed USB mode switch

Use this to specify whether you're using the UA-101 in Hi-Speed USB mode (USB 2.0, 480 Mbps) or in Full-Speed USB mode (USB 1.1, 12 Mbps).

\* When you change the setting of the Hi-Speed USB mode switch, you'll need to cycle the power to the UA-101 to put the new setting into effect.

### ● Hi-Speed USB mode (USB2.0, 480 Mbps)

Turn the Hi-Speed USB mode switch ON if you've connected the UA-101 to a USB 2.0 compliant USB connector.

You'll be able to use the UA-101's full range of functionality; 10 INs (input) and 10 OUTs (output).

\* If the UA-101 is correctly recognized by your computer in Hi-Speed USB mode, the USB indicator will be lit red. If it is blinking, the UA-101 has not been correctly recognized, either because your computer does support USB 2.0, or for some other reason.

\* Hi-Speed USB mode can be used only with Windows XP.



### ● Full-Speed USB mode (USB1.1, 12 Mbps)

Turn the Hi-Speed USB mode switch OFF if you've connected the UA-101 to a USB 1.1 compliant USB connector. You'll be able to record and play back using 2 INs (input) and 2 OUTs (output).

\* If the UA-101 is correctly recognized by your computer in Full-Speed USB mode, the USB indicator will be lit green. If it is blinking, the UA-101 has not been correctly recognized.

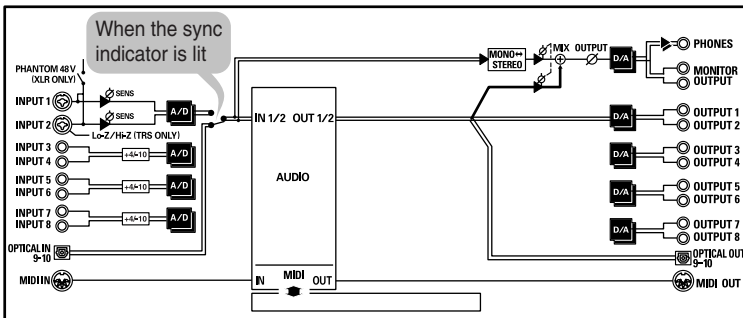

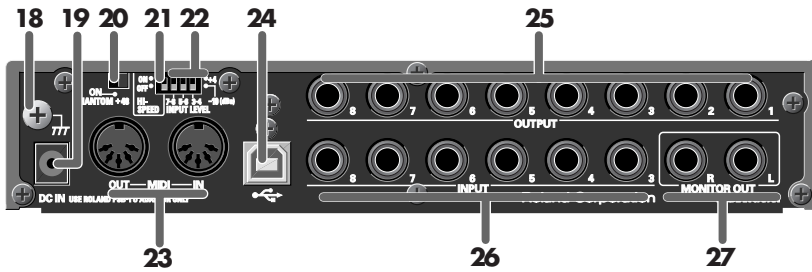

### [Limitations in Full-Speed USB mode (USB 1.1, 12 Mbps)]

- Only sample rates of 44.1 kHz and 48 kHz can be used. If the sample rate select switch is set to any position other than 44.1 kHz or 48 kHz, the **USB indicator (17)** will blink, and the UA-101 will not operate.



## 22. Input level select switches

These select the input gain of **input jacks 3–8 (26)**.

	Nominal input level	Maximum input level
	+4dBu	+16dBu
	-10dBu	+9dBu

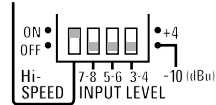

## 23. MIDI IN/OUT connectors

You can connect the MIDI connectors of your MIDI devices here to transmit and receive MIDI messages.

## 24. USB connector

Use a USB cable to connect this to your computer.  
You must use the included USB cable.

## 25. Output jacks 1–8 (nominal output level: +4 dBu)

These jacks output analog audio signals. They support balanced output.

## 26. Input jacks 3–8

Use these jacks to input audio signals from your mixer, audio device, or MIDI tone generator. They support balanced input.

## 27. Monitor output jacks

The sound received via the various input jacks and the sound output by the various audio ports of your computer are mixed and output from these monitor output jacks.

You can use UA-101 Control Panel to adjust the input level for each input jack and the output level of each audio port.

For details, refer to “UA-101 Control Panel” (p. 38).

# Installing the driver

**In order to connect the UA-101 to your computer and use it, you will need the correct driver.**

This section explains how to install the driver you'll need when using the UA-101 in Hi-Speed USB mode on the Windows XP operating system.

If you're using the UA-101 in Full-Speed USB mode, you must use the driver located in the **USB1** folder of the included CD-ROM.

For details on installation, refer to `Readme_E.htm` in the respective folder.

If you're using an operating system other than Windows XP, use the appropriate driver from the USB1 folder of the CD-ROM. Before you install the driver, be sure to read the `Readme_E.htm` file located in each folder.

- Windows XP/2000  
The **USB1 \ XP2K** folder of the CD-ROM
- Windows Me/98  
The **USB1 \ Me98** folder of the CD-ROM
- Mac OS  
The **USB1** folder of the CD-ROM

\* *Use the appropriate driver for your operating system and computer.*

**1** Start up Windows with the UA-101 disconnected. Log onto Windows using a user name that has administrative privileges (such as Administrator).

**2** Open the **System Properties** dialog box.

- 1.** From the Windows **start** menu, choose **Control Panel**.
- 2.** In "Pick a category," click **Performance and Maintenance**.
- 3.** In "or Pick a Control Panel icon," click the **System** icon.



A driver is a piece of software that passes data between the UA-101 and an application program running on your computer when the UA-101 is connected to your computer via a USB cable. The driver sends data from your application software to the UA-101, and sends data from the UA-101 to your application software.



Depending on your setup, the **System** icon may appear directly in the **Control Panel** (Classic view). If so, double-click the System icon.



- 3 Click the **Hardware** tab, then click **[Driver Signing]**.

The **Driver Signing Options** dialog box will open.

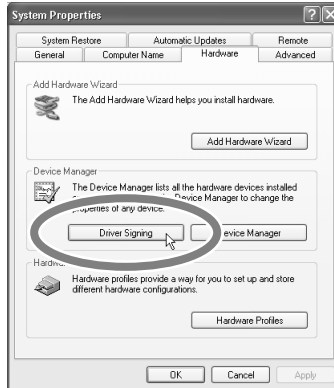

- 4 In the **Driver Signing Options** dialog box, make sure that **“Ignore”** is selected.

If **“Ignore”** is selected, simply click **[OK]**. If this is not set to **“Ignore,”** make a note of the current setting (**“Warn”** or **“Block”**), change the setting to **“Ignore,”** then click **[OK]**.

- 5 Click **[OK]** to close the **System Properties** dialog box.

- 6 Exit all currently running software (applications).

Also close any currently open windows. If you are using antivirus or similar software, you must exit all of these programs as well.

- 7 Prepare the CD-ROM.

Insert the CD-ROM into your computer’s CD-ROM drive.

- 8 From the Windows **start** menu, choose **Run...**

The **Run** dialog box will appear.



If you’ve changed the **“Driver Signing Options,”** return the setting to its original state after you’ve finished installing the driver.



If the message **“Windows can perform the same action each time you insert a disk or connect a device with this kind of file”** appears, **[Cancel]**.

## Installing the driver

- 9 In the Open field of the dialog box, type the following and click **[OK]**.

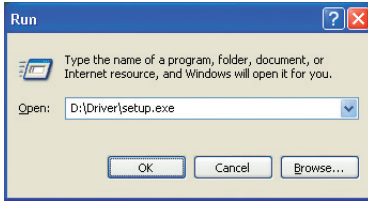

**(Drive name):** \Driver\setup.exe

\* The drive name is "D:" in the example shown here, but may be different on your system. Use the drive name for your CD-ROM drive.

- 10 The **Driver Setup** dialog box will appear.  
Click **[Next]**.

- 11 To begin the installation, click **[Next]** once again.  
Installation will begin.

### MEMO

If you need to check the drive name, choose **start → My Computer**. In the window that appears, note the drive name of the CD-ROM drive into which you inserted the CD-ROM in **step 7**.

The (D:) or (E:) that is indicated for that CD-ROM drive is the drive name.

If the "Driver Signing Options" setting is other than "Ignore" a dialog box like the following will appear.

### If a dialog box with an "!" mark appears

1. Click **[Continue Anyway]**.
2. Installation will begin.

### If a dialog box with an "X" symbol appears...

1. Click **[OK]**.
2. When the "**Found New Hardware Wizard**" appears, click **[Finish]**.
3. Return to **step 1** (p. 16), and reinstall the driver from the beginning.

- 12 The "**Setup is now ready to install the drivers**" dialog box will appear.  
Now you are ready to install the driver.

- 13 On the rear panel of the UA-101, turn the **Hi-Speed USB mode switch ON**.

- 14** Use a USB cable to connect the UA-101 to your computer.
1. With the power switch in the standby position, connect the AC adaptor to the UA-101.
  2. Connect the power cord of the AC adaptor to an AC outlet.
  3. Use a USB cable to connect the UA-101 to your computer.

- 15** Turn on the UA-101's power switch.

A message of **"Found New Hardware"** will appear near the task bar. Please wait.

- 16** If the message **"Connect to Windows Update to search for software?"** appears, choose **"No,"** then click **[Next]**.

- 17** Make sure that **"EDIROL UA-101"** is indicated. Then, choose **"Search for the best driver in these locations"** and click **[Next]**.



Once the connections have been completed, turn on power to your various devices in the order specified. By turning on devices in the wrong order, you risk causing malfunction and/or damage to speakers and other devices.



Turn down the volume of any connected monitor speakers or external amps before you turn on the power. Even with the volume all the way down, you may still hear some sound when the power is switched on, but this is normal, and does not indicate a malfunction.

If the "Driver Signing Options" setting is other than "Ignore," a dialog box like the following will appear.

### If a dialog box with an "!" mark appears

1. Click **[Continue Anyway]**.
2. Installation will begin.

- 18** The **Completing the Found New Hardware Wizard** dialog box will appear.

Click **[Finish]**.

A message of **"Found New Hardware"** will appear near the task bar. Please wait.

- 19** In the **Driver Setup** dialog box, click **[Close]**.

This completes driver installation.

If the Change System Settings dialog box appears, click **[Yes]**. Windows will restart automatically.

If you changed the “Driver Signing Options” setting (step 4 on p. 17), restore the original settings after Windows has restarted.

1. Log onto Windows as the user who installed the driver.
2. From the Windows **start** menu, choose **Control Panel**.
3. In “**Pick a category,**” click **Performance and Maintenance**.
4. In “**or Pick a Control Panel icon,**” click the **System** icon. The **System Properties** dialog box will appear.  
*\* Depending on your system, the **System** icon may appear directly in the **Control Panel** (Classic view). If so, double-click the **System** icon.*
5. Click the **Hardware** tab, then click **[Driver Signing]**. The **Driver Signing Options** dialog box will appear.
6. In the **Driver Signing Options** dialog box, restore the original setting (“Warn” or “Block”) and click **[OK]**.
7. Click **[OK]**. The System Properties dialog box will close.

Next, in order to ensure that audio and MIDI processing occurs smoothly, you need to make settings so that Background Services is given priority.  
(→ “**Giving priority to Background Services**” (p. 21))

# Giving priority to Background Services

If you don't make this setting, you may experience problems such as clicks or pops in the sound. To ensure that audio and MIDI data is handled smoothly, proceed as follows to make this setting.

- 1 Open the **System Properties** dialog box.
  1. From the Windows **start** menu, choose **Control Panel**.
  2. In “**Pick a category**,” click “**Performance and Maintenance**”.
  3. In “**or Pick a Control Panel icon**,” click the **System** icon.
- 2 Click the **Advanced** tab.
- 3 In the right side of the **Performance** area, click [**Settings**]. The **Performance Options** dialog box will open.
- 4 Click the **Advanced** tab.
- 5 In the **Processor Scheduling** area, choose “**Background services**,” and click [**OK**].
- 6 In the **System Properties** dialog box, click [**OK**]. The **System Properties** dialog box will close.

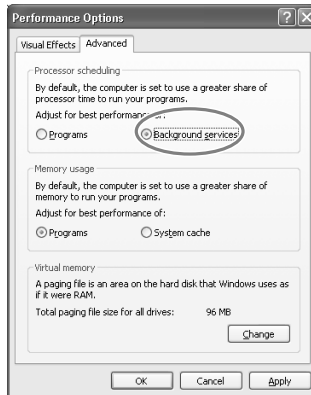

Next, you'll make audio device and MIDI device settings.  
 (→ “**Driver settings**” (p. 22))



Depending on your setup, the **System** icon may appear directly in the **Control Panel** (Classic view). If so, double-click the **System** icon.

# Driver settings

## About input and output devices

In order for you to take full advantage of your software, you must select the correct device. The UA-101 supports WDM and ASIO audio devices.

### Audio devices

	SEPARATED ports disabled (off)	SEPARATED ports enabled (on)	Number of ports usable
Audio output device (WDM)	EDIROL UA-101	EDIROL UA-101	10 Out
			2 Out 2 Out 2 Out
Audio input device (WDM)	EDIROL UA-101	EDIROL UA-101	12 In
		<b>UA-101 1-2 SEPARATED</b> : <b>UA-101 9-10 SEPARATED</b> <b>UA-101 Mon SEPARATED</b> You can record the UA-101's monitor output without modification. (Refer to the block diagram → front cover)	2 In 2 In 2 In 2 In
ASIO device	EDIROL UA-101		12 In 10 Out

\* For more about turning Separated ports on/off, refer to **“Using Separated ports”** (p. 42).

### MIDI devices

MIDI OUT	<b>EDIROL UA-101</b> When you specify EDIROL UA-101 as the output port in your sequencer or other software, the messages will be transmitted from the UA-101's MIDI OUT connector.
MIDI IN	<b>EDIROL UA-101</b> When you specify EDIROL UA-101 as the input port in your sequencer or other software, the messages will be received from the UA-101's MIDI IN connector.

\* For details on making settings in your software, refer to the owner's manual for your software. You should also read **“Software settings”** (p. 33).

\* If you're unable to choose the UA-101 device in the device settings of your software, it is possible that the UA-101 driver has not been installed correctly. Please reinstall the driver.

**WDM**

Use this driver if you're using the UA-101 with the software listed below.

You'll be able to use 12 inputs and 10 outputs.

- Software that is compatible with the WDM driver mode, such as SONAR
- Software that is compatible with DirectSound
- Playing back WMA Professional format 5.1 files in Windows Media Player  
In "**Advanced Audio Properties**," choose "**5.1 surround sound speakers**" as the "**Speaker setup**" setting.
- Conventional software such as Media Player.  
For details on settings, refer to "**Input/output device settings**" (p. 24)

\* *If you want to use input/output jacks 3–10 in software such as Windows Media Player that does not support WDM or ASIO, you'll need to make settings in UA-101 Control Panel. For details, refer to "**Using Separated ports**" (p. 42).*

**ASIO**

Use this driver if you're using the UA-101 with ASIO compatible software such as Cubase.

Choose "EDIROL UA-101" in the ASIO settings of your software.

You'll be able to use 12 inputs and 10 outputs.

- \* *To prevent audio loops or duplicate monitoring, turn software monitoring off, or use the ASIO Direct Monitor function of your software.*
- \* *When using the UA-101 with ASIO, we recommend that you not set your software to use the Microsoft GS Wavetable SW Synth. This will lighten the processing load.*

# Input/output device settings

If you're using the UA-101 with the Media Player included with Windows, make input/output device settings as follows.

The method of making device settings may differ for your software. For details, refer to the owner's manual for your software.

**1** Open the **Sounds and Audio Devices Properties** dialog box.

1. From the Windows **start** menu, choose **Control Panel**.
2. In "Pick a category," click **Sound, Speech, and Audio Devices**.
3. In "or Pick a Control Panel icon," click the **Sounds and Audio Devices** icon.

**2** Click the **Audio** tab.

**3** In the "Sound playback, Sound recording, and MIDI music playback," click each **Default device** box and from the list that appears, choose the following devices.

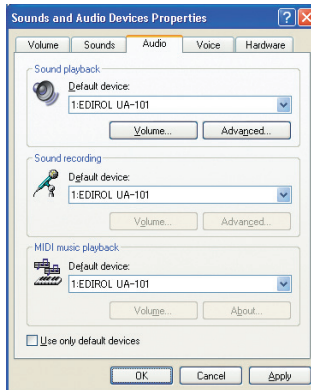

<b>Sound playback</b>	EDIROL UA-101
<b>Sound recording</b>	EDIROL UA-101
<b>MIDI music playback</b>	EDIROL UA-101

**4** Click **[OK]** to close the **Sounds and Audio Devices Properties** dialog box.

This completes audio and MIDI input/output settings.



Depending on your setup, the **System** icon may appear directly in the **Control Panel** (Classic view). If so, double-click the **System** icon.



If you are using sequencer software, you will need to make audio and MIDI device settings from within your software. For details, refer to the owner's manual for the software you are using.



## Verifying that you hear sound

When you've made connections and settings correctly, play back the sample data to verify that you hear sound. Here we'll use standard Windows functionality to play back the sample data provided on the included CD-ROM. Refer to "**Basic connections**" (p. 27) and connect your headphones or monitor speakers appropriately.

- 1 Insert the CD-ROM into the CD-ROM drive of your computer.
- 2 From the **SampleSong** folder of the CD-ROM, drag **TTears(.mp3)** onto your desktop.
- 3 Set the UA-101's **sample rate select switch** to **48 kHz**.  
After you've changed the sample rate, you'll need to switch off the UA-101, then turn it on again.
- 4 Right-click the **TTears(.mp3)** file you copied, and choose **Play** from the menu that appears.  
Playback will begin.

If the sample data plays correctly, the UA-101 is correctly connected to your computer, and the driver has also been installed correctly.

### NOTE

Use of the song data supplied with this product for any purpose other than private, personal enjoyment without the permission of the copyright holder is prohibited by law. Additionally, this data must not be copied, nor used in a secondary copyrighted work without the permission of the copyright holder.

### NOTE

The contents of the menu that appears will depend on your system.

### MEMO

If the volume is low or inaudible, try turning the UA-101's **direct monitor volume knob** (p. 12) toward the left of center.

### MEMO

Also turn off the direct monitor soft control switch.

## About the demo songs

The SampleSong folder on the included CD-ROM contains the following demo songs. Enjoy the songs in the format that's appropriate for your system. Copy the songs onto your computer's hard disk before playing them.

\* *The demo songs were created at 48 kHz. Set the UA-101's sample rate switch to 48 kHz. If you change the setting of the sample rate switch, you'll need to switch off the UA-101, then turn it on again.*

### for SONAR folder

Contains the demo songs as SONAR project files (.cwb).

### for Cubase folder

Contains the demo songs as Cubase VST song files (.all) and as Cubase SX project files (.cpr).

If you're using the Cubase SX demo version, the songs will not play correctly because certain functionality (such as effects) is not available.

### Software settings

Before you start up your software, use a USB cable to connect the UA-101 to your computer, and power up the UA-101.

If your software allows you to make MIDI and audio input/output settings, choose **EDIROL UA-101**

For details, refer to the owner's manual for the software you're using. Also refer to "**Software settings**" (p. 33).

If you're using your software with "software monitoring" turned on, turn off the UA-101's hardware monitoring (direct monitor) to avoid an audio feedback loop or double monitoring.



For the most recent information, refer to <http://www.edirol.net/>

# Basic connections and settings

This chapter explains basic connections and data flow for the UA-101. You should also refer to the block diagram printed on the front cover as you read this chapter.

- \* To prevent malfunction and/or damage to speakers or other equipment, you must turn down the volume and turn off the power on all your equipment before you connect anything to the UA-101.
- \* When connection cables with resistors are used, the volume level of equipment connected to the inputs (Input jacks) may be low. If this happens, use connection cables that do not contain resistors, such as those from the Roland PCS series.

## Basic connections

Use a USB cable to connect the UA-101 to your computer.

Both MIDI data and audio data are transferred over the USB cable.

When you connect headphones or monitor speakers as shown in the diagram, you'll be able to monitor the playback from your software, or the sound of instruments or audio devices connected to the UA-101.

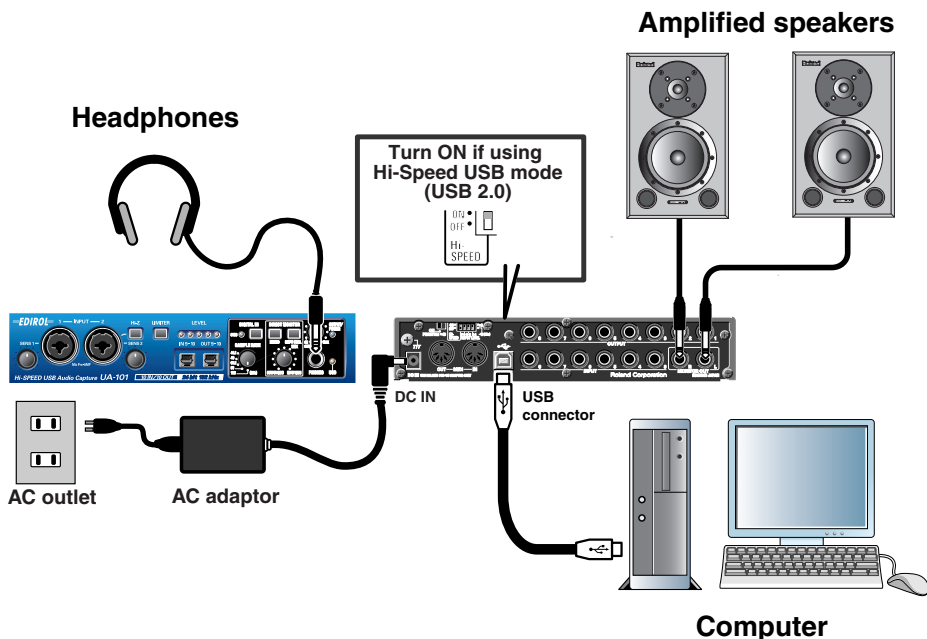

# Recording a mic or guitar

When you record on your sequencer by singing or playing your guitar along with audio data that's played back by your computer, only your vocal or guitar performance will be recorded on the computer.

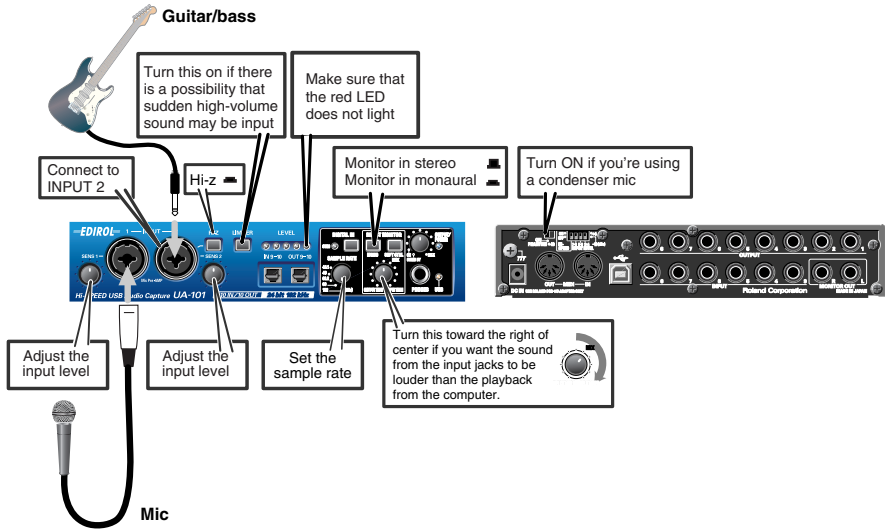

## Connections

The sound from the mic connected to INPUT 1 will be recorded into your computer on the left (L) channel. If you connect it to INPUT 2, the sound will be recorded on the right (R) channel. If you're using a guitar, connect it to INPUT 2.

Don't connect anything to input jacks you're not using.

Howling could be produced depending on the location of microphones relative to speakers. This can be remedied by:

1. Changing the orientation of the microphone(s).
2. Relocating microphone(s) at a greater distance from speakers.
3. Lowering volume levels.

## Input sensitivity knob

Use the input sensitivity knob to adjust the input level. In order to record at the best possible audio quality, adjust the input sensitivity knob until it is as high as you can get it without causing the input/output level indicator to light in red.

## Input impedance select switch

If a mic is connected to INPUT 2	Off
If a guitar is connected to INPUT 2	On

## Limiter switch

If you turn on the limiter switch, the input level will automatically be adjusted if a sudden loud sound is applied to the combo input jack. This makes it less likely that clipping noise will occur.

## Sample rate select switch

Set this to the same sample rate that you've selected in your recording software. After you've changed the sample rate setting of the UA-101, you must cycle the power to the UA-101 in order for the setting to take effect.

## STEREO/MONO select switch (Direct Monitor section)

Use this to select to monitor the input signal in stereo or in monaural.

## Direct Monitor Soft Control switch

Turn this on if you want to control input monitoring from ASIO 2.0 compliant software or from **UA-101 Control Panel** (p. 38).

## Direct monitor volume

This adjusts the balance between the monitor volume and the volume of the audio playback from the computer.

Using the Direct Monitor volume control to adjust the volume will not affect the recording level.

## Phantom power switch

If you're using condenser mics, turn on the phantom power switch.

*\* If you've connected a device that does not require phantom power, you must turn the phantom power switch off to avoid damaging your device.*

# Recording a digital signal

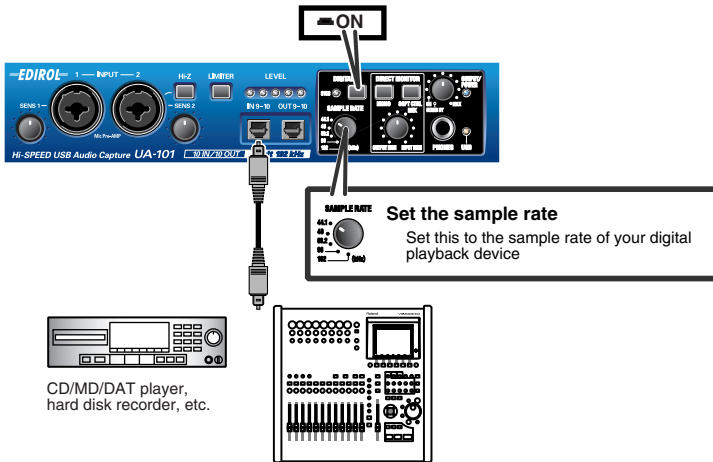

## Connections

Connect your digital audio device to the digital input connector.

## Sample rate select switch

Set this to match the sample rate you've selected on your digital audio playback device and in your recording software.

After you've changed the sample rate setting of the UA-101, you must cycle the power to the UA-101 in order for the setting to take effect.



You can't record digital signal if you've selected 192 kHz.

## Digital input switch

Turn this on so that the UA-101 will synchronize to the digital signal being input to the digital input connector.

If the UA-101 is synchronized to the incoming signal, the SYNC indicator will light green. If the indicator is blinking green, synchronization has not been achieved. Please make sure that the sample rate of the connected digital device matches the setting of the UA-101's sample rate select switch.

## Direct monitor volume

This adjusts the monitor volume.

Using the Direct Monitor volume control to adjust the volume will not affect the recording level.

# Connecting various equipment

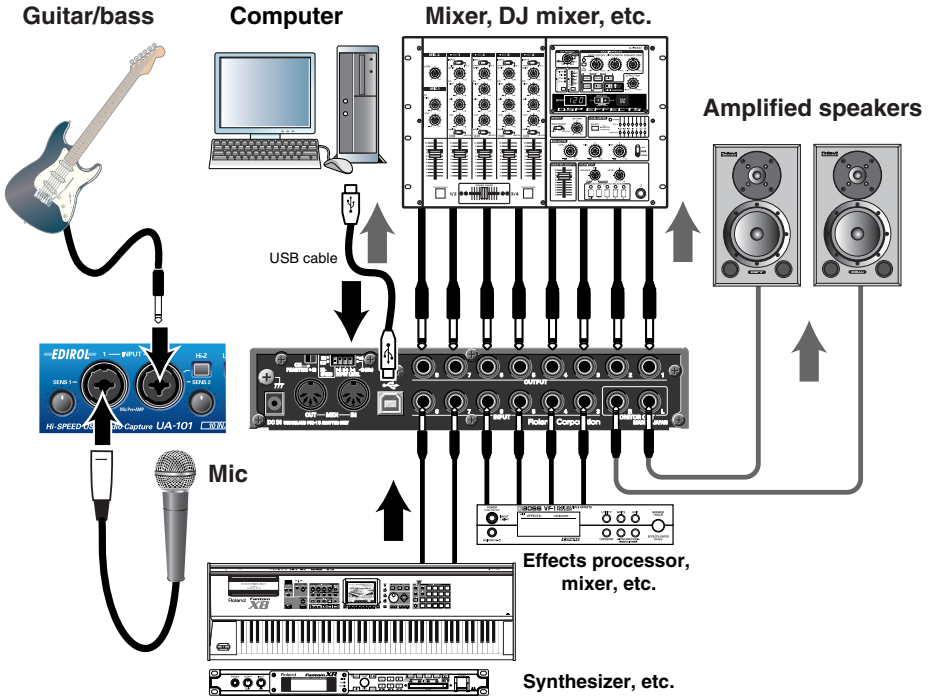

## Connections

Connect output jacks 1–8 to your external mixer, etc.

Connect the outputs of your external mixer, synthesizer, etc. to input jacks 3–8.

## Direct monitor volume

This adjusts the monitor volume.

Using the Direct Monitor volume control to adjust the volume will not affect the recording level.

## 5.1 channel monitoring

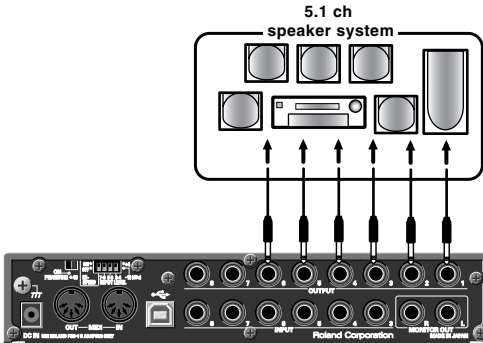

### Connections

Connect phone-type audio cables to the output jacks.

### Patching within the UA-101

Use UA-101 Control Panel to patch the connections as follows.

For details on UA-101 Control Panel, refer to “**UA-101 Control Panel**” (p. 38).

In the PATCH BAY area of UA-101 Control Panel, set OUTPUT 1-2 to WAVE OUT 1-2, OUTPUT 3-4 to WAVE OUT 3-4, and OUTPUT 5-6 to WAVE OUT 5-6.

### Settings in Windows

1. From Windows **Control Panel**, open **Sounds and Audio Devices Properties** dialog box. (→“**Input/output device settings**” (p. 24))
2. Click the **Audio** tab.  
In the **Sound playback** area, click the **Default device** field and choose **EDIROL UA-101** from the list that appears.
3. In the **Sound playback** area, click [**Advanced**].
4. Click the **Speakers** tab.  
In the **Speaker setup** field, choose **5.1 surround sound speakers**.
5. Click [**OK**] to close the **Advanced Audio Properties** dialog box.
6. Click [**OK**] to close the **Sounds and Audio Devices Properties** dialog box.

\* *In your software, choose a setting such as “6 speaker mode” or “5.1 ch surround mode.”*



# Software settings

You will need to make audio and MIDI device settings for the software you're using. Here are some examples for typical software applications.

## SONAR 4

In this example we are using SONAR 4 Producer Edition.



You must make the following settings if you have switched the UA-101's sample rate or have changed the buffer size in the UA-101 Driver settings dialog box.

1. Power up the UA-101, and then start up SONAR.
2. From SONAR's **Options** menu, choose **Audio** to open the **Audio Options** dialog box.
3. Click the **Advanced** tab.  
In the **Playback and Recording** area, verify that **Driver Mode** is set to **WDM/KS**.  
*\* If you change this setting, click [OK] and restart SONAR.  
Restart SONAR, and from the **Options** menu, choose **Audio** to open the **Audio Options** dialog box.*

4. In the **General** tab, set **Audio Driver Bit Depth** to **24**.

Set the **Sampling Rate** to the same setting as the UA-101's sample rate select switch.  
If you change this setting, click **[OK]** and exit SONAR.

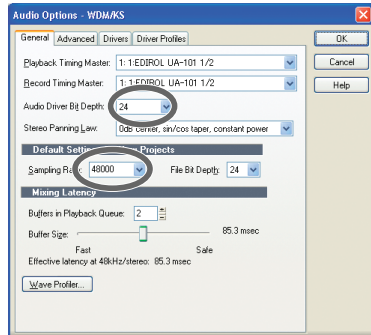

- \* If the **Audio Driver Error** dialog box appears, click **[Use Anyway]**. If you click **[Disable]**, the setting will be discarded.*

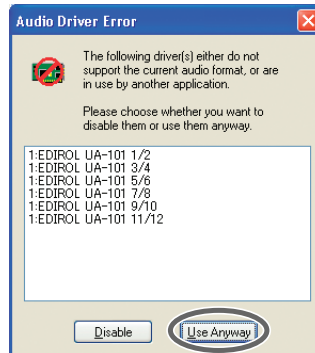

## Software settings

- Restart SONAR, and from SONAR's **Options** menu, choose **Audio** to open the **Audio Options** dialog box.
- In the **General** tab, click **Wave Profiler**.  
When **Wave Profiler** is finished, click **[Close]**.
- Click the **Drivers** tab.

In the lists of **Input Drivers** and **Output Drivers**, click the following devices to highlight them (white characters on blue background), and un-highlight all other devices. Click **[OK]**.

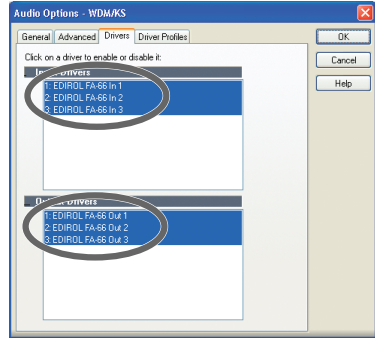

Input devices	Output devices
EDIROL UA-101 1/2	EDIROL UA-101 1/2
EDIROL UA-101 3/4	EDIROL UA-101 3/4
EDIROL UA-101 5/6	EDIROL UA-101 5/6
EDIROL UA-101 7/8	EDIROL UA-101 7/8
EDIROL UA-101 9/10	EDIROL UA-101 9/10
EDIROL UA-101 11/12	–

- Restart SONAR, and from SONAR's **Options** menu, choose **Audio** to open the **Audio Options** dialog box.
- In the **General** tab, make sure that **Playback Timing Master** is set to **EDIROL UA-101 1/2**, and **Record Timing Master** is set to **EDIROL UA-101 1/2**.

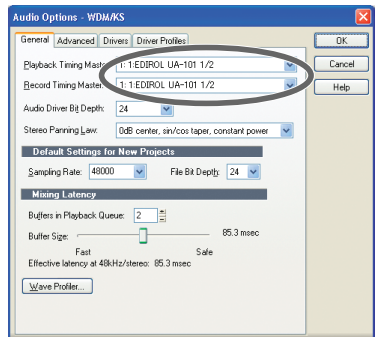

**10.** Click the **Driver Profiles** tab.

Select **EDIROL UA-101 (6 in, 5 out)** as the setting for “**Show Profile for,**” and then select “**32 bit PCM, left-justified**” as the setting for “**Stream > 16 bit data as.**”

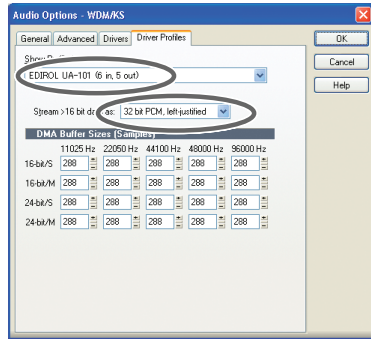

**11.** Click [**OK**] to close the **Audio Options** dialog box.

**12.** From SONAR’s **Options** menu, choose **MIDI Devices** to open the **MIDI Devices** dialog box.

**13.** In the **MIDI Devices** dialog box, choose the UA-101 in the **Inputs** area and the **Outputs** area.

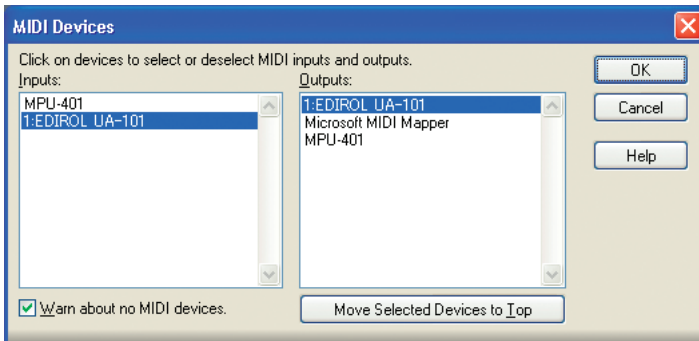

**14.** Restart SONAR.

**15.** Open the **Audio Options** dialog box once again as described in step 2. Verify that the audio device settings are correct.

# Cubase SX

In this example we are using the Windows version of Cubase SX3.

1. Power up the UA-101, and then start up Cubase.
2. From the **Devices** menu, choose **Device Setup** to open the **Device Setup** dialog box.
3. In the **Devices** list at the left side of the dialog box, choose **VST Audiobay**.
4. From the drop-down list for **ASIO Driver**, choose **EDIROL UA-101**.
5. Click **[OK]** to close the **Device Setup** dialog box.

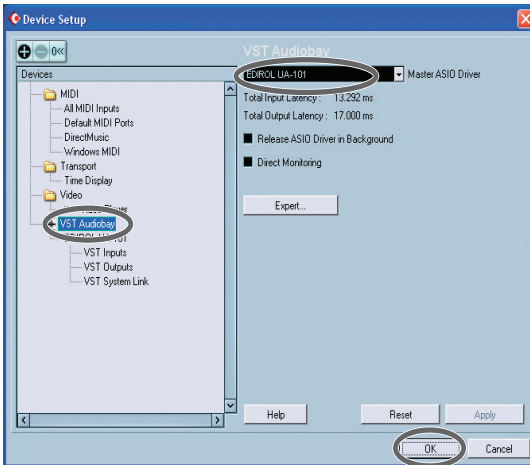

If you experience clicks or pops in the sound, click **[Expert]** to open the **VST Engine Expert Settings** dialog box. Setting the **Audio Priority** to **“Very High”** may reduce clicks and pops.

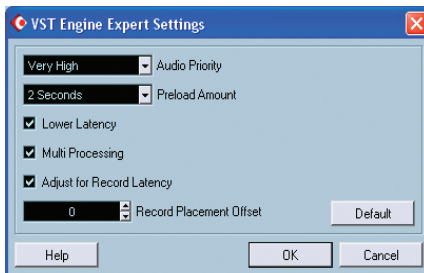

If you’re using Cubase SX, and the UA-101’s sample rate setting differs from the setting of your Cubase SX project, a message such as **“Unable to set the sample rate”** will appear, or you may be unable to record or play back correctly. In this case, open **“Project settings,”** verify that the sample rate settings match, and then click **[OK]**.



# Various settings

Various settings of the UA-101 can be made from your computer.

You will use UA-101 Control Panel to make these settings.

UA-101 Control Panel lets you adjust the monitor mixer's on/off, volume, mute, and pan settings. You can also adjust the patching, and make the settings described in “**Adjusting the audio latency**” (p. 41) and “**Using ASIO Direct Monitor**” (p. 44).

## Internal blocks of the UA-101

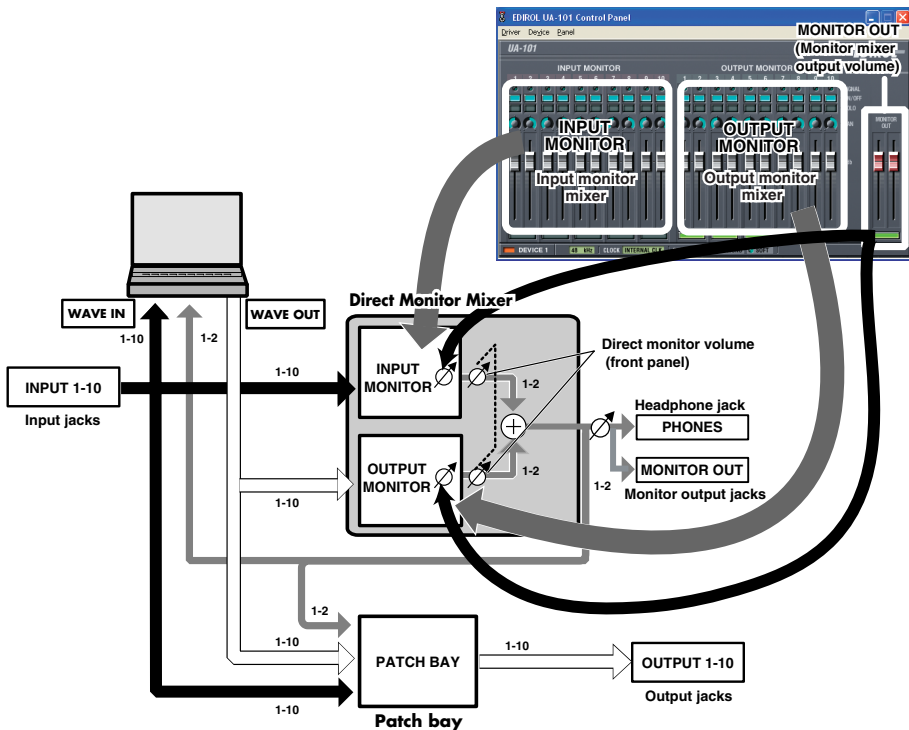

# UA-101 Control Panel

When you install the UA-101 driver, the UA-101 Control Panel software is also installed. This section provides an overview of how to use UA-101 Control Panel. For a more detailed explanation, refer to the Readme\_E.htm file in the Driver folder of the CD-ROM.

## Startup

1. From the Windows **Start** menu, choose **Control Panel**.
2. Click “**Switch to Classic view**” to choose the Classic view.  
Depending on your system, the Classic view may already be selected. If so, proceed to the next step.
3. In the **Control Panel**, double-click the **EDIROL UA-101** icon.  
**UA-101 Control Panel** will appear.



4. Turn the UA-101's **Direct Monitor Soft Control switch** on.

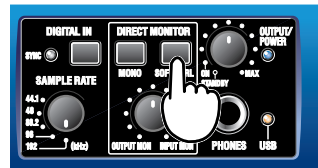

When this switch is off, all settings of the Direct Monitor Mixer will be ignored (i.e., bypassed), allowing you to monitor the audio inputs at all input jacks and the outputs from your computer just as they are. This provides a convenient way to temporarily ignore the software settings when you need to do things such as check the connections.

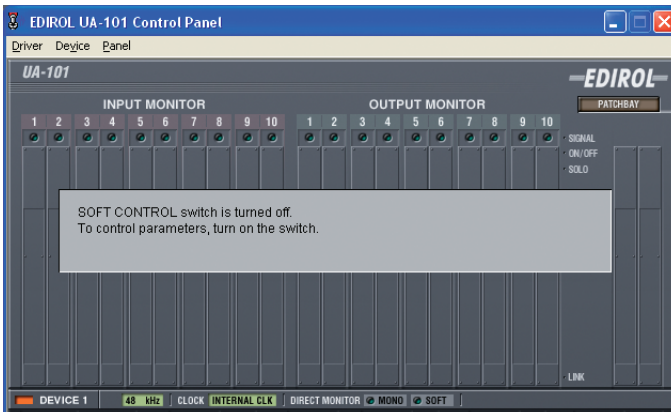

The above is displayed if you start up UA-101 Control Panel when the direct monitor soft control switch is off.

# Screen items and what they do

## Main window

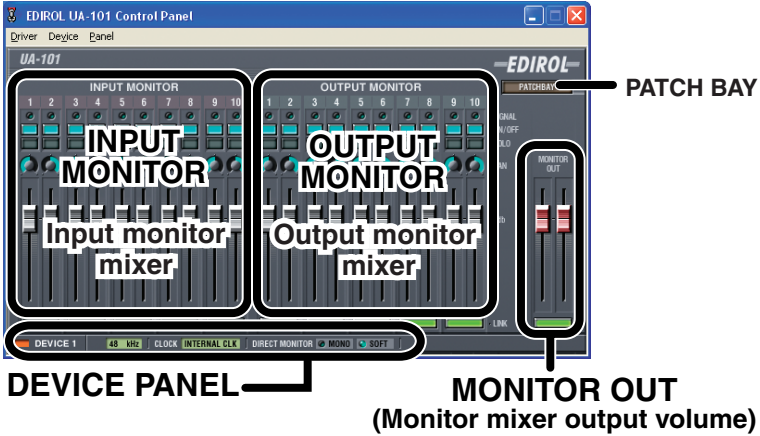

Each block of the UA-101 itself can be directly controlled from UA-101 Control Panel.

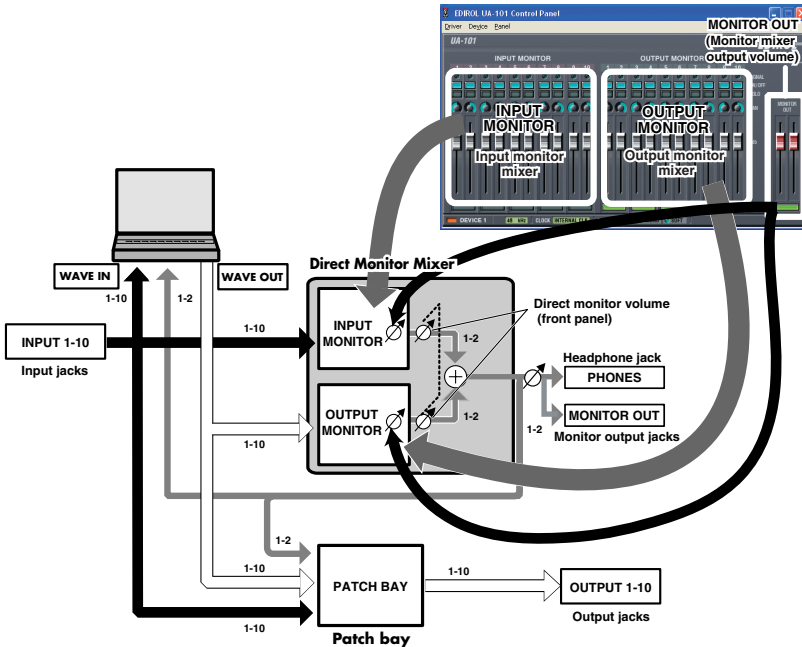

### PATCH BAY

When you click the PATCH BAY button, a dialog box for making Patch Bay settings will appear. If the settings have been modified from the default state, the PATCH BAY button will be lit.

Here you can select the signal that is sent to each of the UA-101's output jacks. The five stereo channels of audio data sent from the computer, the audio data input via the UA-101's input jacks 1–10, and MONITOR OUT can all be sent to the UA-101 output jacks you specify.

### INPUT MONITOR

Here you can control the monitor level and balance of the audio data that is received via the UA-101's input jacks 1–10.

\* *These settings are ignored if the front panel Direct Monitor Soft Control switch is turned off.*

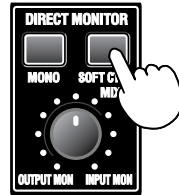

### OUTPUT MONITOR

Here you can control the balance of the five stereo channels of audio data that are sent from the computer to your headphones or monitoring system.

\* *These settings are ignored if the front panel Direct Monitor Soft Control switch is turned off.*

<b>SIGNAL</b>	This will light when a signal is being input to the corresponding channel.
<b>ON/OFF</b>	Switches monitoring on/off.
<b>SOLO</b>	Switches solo on/off.
<b>PAN</b>	Drag the knob to left or right to adjust the panning.
<b>VOLUME</b>	Drag the slider up or down to adjust the volume.
<b>LINK</b>	Selects whether Monitor on/off, Solo, and Volume settings will be linked for stereo pairs.

### DEVICE PANEL

This displays the state of the various panel switches of the device.

## Recalling and storing memories

Up to five sets of settings can be stored within the UA-101 itself.

These stored memories can be recalled or stored using UA-101 Control Panel.

For the procedure, refer to `Readme_E.htm` on the included CD-ROM.



# Adjusting the audio latency

You can adjust the audio latency by changing the driver settings. To adjust the latency, adjust the **Audio Input/Output Buffer Size** in the **Driver Settings** dialog box.

Latency is the time from when your software plays back audio data until you actually hear the sound from an audio device such as the UA-101.

1. In UA-101 Control Panel, choose **Driver Settings** from the **Driver** menu.  
Adjust the **Audio Input/Output Buffer Size**.

2. Set the “**Audio Input/Output Buffer Size**” to the far left (Min.).  
Click **[OK]** to close the **Driver Settings** dialog box.

3. Restart the software that’s using the UA-101.  
If your software provides an audio device test function, execute that test function.

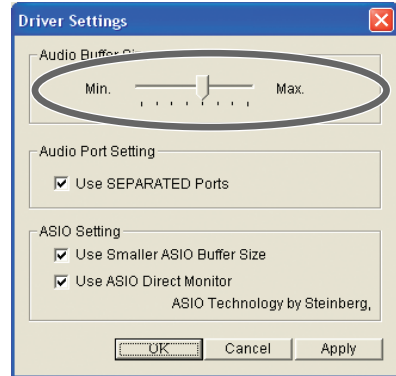

4. Play back audio data from your software.  
If you hear clicks or pops, repeat this procedure, gradually increasing the buffer size in step 2 until you no longer hear clicks or pops.

\* *The audio settings of your software may also provide an adjustment for buffer size or latency. For details, refer to the owner’s manual for your software.*

# Using Separated ports

In software that does not support WDM or ASIO, such as Windows Media Player, you won't be able to freely select jacks other than input/output jacks 1 and 2 as input/output destinations.

If you want to select the UA-101's input jacks 3–10 or output jacks 3–10 as input/output destinations in your software, you'll need to enable (turn on) Separated Ports so that these jacks will be available to select.

For the corresponding ports, refer to **“About input and output devices”** (p. 22).

*\* If you're using software that supports multiple ports, such as SONAR, you don't need to enable Separated Ports.*

1. In UA-101 Control Panel, choose Driver Settings from the Driver menu. The **Driver Settings** dialog box will open.

2. Select the **“Use SEPARATED Ports”** check box. Separated Ports will be enabled.

3. Click **[OK]** to close the **Driver Settings** dialog box. Now you'll be able to select the following ports from your software.

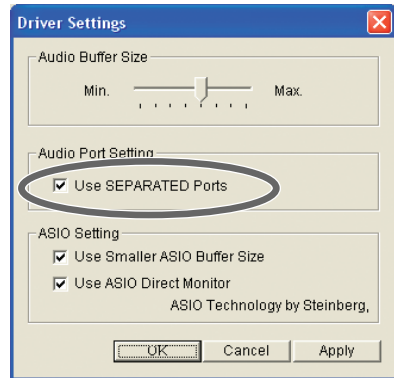

SEPARATED ports	UA-101 input jacks	UA-101 output jacks
UA-101 1-2 SEPARATED	Input jacks 1–2	Output jacks 1–2
UA-101 3-4 SEPARATED	Input jacks 3–4	Output jacks 3–4
UA-101 5-6 SEPARATED	Input jacks 5–6	Output jacks 5–6
UA-101 7-8 SEPARATED	Input jacks 7–8	Output jacks 7–8
UA-101 9-10 SEPARATED	Input jacks 9–10	Output jacks 9–10
UA-101 MON SEPARATED	The signal that is sent from the monitor output jacks of the UA-101 itself can be recorded without modification. (Refer to the block diagram → front cover)	

## Minimize the ASIO buffer size

If you're using the UA-101 with ASIO-compatible software, you can minimize the buffer size. If you experience clicks or pops in the sound, uncheck this check box.

\* After adjusting the audio input/output buffer size (p. 41), check the “**Use Smaller ASIO Buffer Size**” setting, and make sure that you do not experience clicks or pops before you continue.

1. In UA-101 Control Panel, choose **Driver Settings** from the **Driver** menu. The **Driver Settings** dialog box will open.
2. Select the “**Use Smaller the ASIO Buffer Size**” check box.
3. Click **[OK]** to close the **Driver Settings** dialog box.

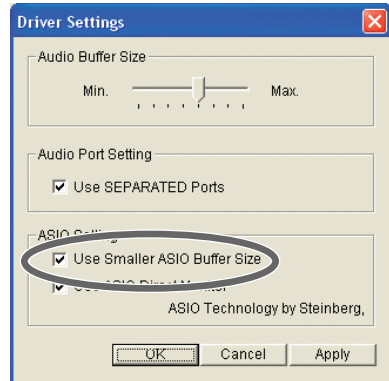

# Using ASIO Direct Monitor

If you're using the UA-101 with ASIO 2.0 compatible software, you can let your software control the on/off status of the UA-101's Input Monitor function.

1. In UA-101 Control Panel, choose **Driver Settings** from the **Driver** menu. The **Driver Settings** dialog box will open.
2. Select the “**Use ASIO Direct Monitor**” check box.
3. Click **[OK]** to close the **Driver Settings** dialog box.



- \* Your software may also have an ASIO Direct Monitor setting as one of the items in its audio settings. For details, refer to the owner's manual for your software.
- \* When you use ASIO Direct Monitor, the monitor function may switch on/off at unexpected times depending on your recording procedure or on the settings in your software. If so, clear the check box in step 2 to disable ASIO Direct Monitor.

# System settings

## Restoring the factory settings (Factory Reset)

This operation will restore the following items set from UA-101 Control Panel to their factory-set state.

- Direct monitor mixer (p. 39)
- Patch bay (p. 40)
- Memory (p. 40)

1 Disconnect the USB cable from the UA-101.

2 Turn the **power switch** all the way toward the left to the **STANDBY** position.

3 Press the **digital input switch**, **STEREO/MONO select switch**, and **direct monitor soft control switch** to turn them all on ( | pressed inward).

4 Set the **sample rate switch** to 192 kHz.

5 Turn the **power switch** toward the right to turn on the power. The **sync indicator** will light, then immediately go out.

6 Within three seconds, turn the **sample rate select switch** to 96 kHz. Then, immediately turn it back to 192 kHz.

\* You must perform these operations no longer than three seconds apart from each other.

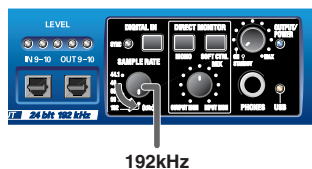
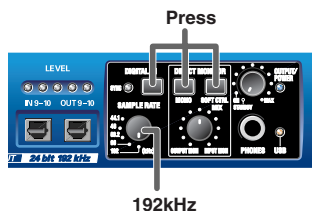

7 The **input/output level indicators** will blink, and the UA-101 will be reset to its factory-set state. Turn the UA-101 off, then on again.

# Troubleshooting

If you experience problems, read this chapter first/ It contains tips for solving most problems.

## Driver-related problems (Windows)

### Can't install the driver correctly

#### **Is the Hi-Speed USB mode select switch set correctly?**

Set the Hi-Speed USB mode select switch appropriately for the USB mode you're using.

#### **You attempted to install as described in "Installing the driver," but did not succeed.**

Install the UA-101 driver once again as described in "Installing the driver" (p. 16). Also check the Device Manager to see whether "Other device," "Unknown device," "?," "!", or "x" is shown for any device. If you see such a device, delete it.

#### **Does the Device Manager show "Other device," "Unknown device," or any device marked with "?," "!", or "x"?**

If driver installation did not end successfully, the installed driver may remain in an incomplete state.

Install the UA-101 driver once again as described in "Installing the driver" (p. 16).

#### **Is the UA-101 connected correctly?**

Make sure that you have used a USB cable to correctly connect the UA-101 to the USB connector of your computer.

#### **Is the UA-101 powered up?**

Make sure that the UA-101's power is on. Make sure that the POWER switch is on.

#### **Could other applications or resident software (such as an anti-virus program) be running?**

Installation may not occur correctly if other programs are running. Be sure to close all other programs before installing.

#### **Are you attempting to install from a networked CD-ROM drive?**

You cannot install from a networked CD-ROM drive.

#### **Could the CD-ROM or the lens of your CD-ROM drive be dirty?**

If the CD-ROM or the lens of your CD-ROM drive are dirty, the installer may not work correctly. Use a commercially available CD cleaner or lens cleaner to clean the CD-ROM and/or lens.

**Are the power conservation settings of your computer turned off?**

If power conservation settings are turned on for your computer, disable these settings. (For details on how to disable them, refer to the owner’s manual of your computer.)

**Is there enough free space on your hard disk?**

Delete unneeded files to increase the amount of free space.  
After deleting the file(s), empty the recycling bin.

**Is the USB connector enabled on your computer?**

Refer to the owner’s manual for your computer, and verify that the USB connector of your computer is enabled. The driver cannot be installed unless the USB connector is enabled.

**Does your computer meet the USB specification?**

Operation may be unstable if you are using a computer that does not electrically meet the USB specification. If so, you may be able to solve the problem by connecting a USB repeater hub that has its own power supply.

**Can’t install/uninstall the driver**

**Did you log onto Windows as a user with administrative privileges?**

In order to install/uninstall/reinstall the UA-101 driver in Windows, you must log onto Windows as a user with administrative privileges, such as Administrator.

**Did you make the “Driver Signing Options” setting?**

You must set “Driver Signing Options” in order to install/reinstall the driver.  
(p. 17)

**Windows displays an “Installing Hardware,” “Did not find digital signature” dialog box.**

**Did you make the “Driver Signing Options” setting?**

You must set “Driver Signing Options” in order to install/reinstall the driver.  
(p. 17)

**Computer is sluggish**

**Have you updated Windows XP?**

If you have not updated Windows XP, the CPU may be heavily burdened when you record or play back audio, and your system will not operate correctly. Before you begin using the UA-101, please perform either of the following actions. For details on updating, refer to the enclosed pamphlet.

- Update to Windows XP SP2 (recommended)
- Install the update module in Windows XP SP1

# Can't record or play back audio or MIDI

## No sound

### **Are the volume controls of the UA-101 set appropriately?**

Adjust the monitor volume knob and direct monitor volume of the UA-101's front panel.

### **Is your audio playback system (e.g., stereo) connected correctly?**

Make sure that the UA-101's output jacks are correctly connected using audio cables to the input jacks of your audio playback system.

**Refer to:** "Basic connections and settings" (p. 27)

### **In UA-101 Control Panel, could the Output Monitor output setting be turned off?**

The audio output will be muted if the Output Monitor output setting is turned off in UA-101 Control Panel or if the slider is all the way down. Turn on the monitor setting in UA-101 Control Panel.

**Refer to:** "UA-101 Control Panel" (p. 38)

### **Is the patch bay set correctly?**

Depending on the patch bay settings, playback from the computer may not be routed properly to the output jacks.

Check the patch bay settings in UA-101 Control Panel.

**Refer to:** "UA-101 Control Panel" (p. 38)

### **Did you connect/disconnect the USB cable or cycle the power to the UA-101 while your software was running?**

You must close all software that uses the UA-101 before powering off the UA-101. If you start up your computer with the UA-101 connected, operation may become unstable for some computers.

In this case, connect the UA-101 after starting up your computer.

### **Could your computer have entered Standby (Suspend) or Sleep mode?**

After your computer wakes up, close all software that had been using the UA-101, and then cycle the power to the UA-101.

### **Have you specified the audio and MIDI data output destination in the operating system?**

Depending on the software you are using, you may need to specify the UA-101 as the audio data output destination for your computer.

**Refer to:** "Driver settings" (p. 22)



**Is the driver installed correctly?**

If you're using Windows, you'll need to install a driver in order to play back audio/MIDI data via the UA-101.

**Refer to:** "Installing the driver" (p. 16)

**Are you running numerous software programs?**

An error message may appear if numerous software programs are running simultaneously. If this occurs, close the software you are not using.

In Windows, a program is still running if it remains in the taskbar even after you close its window; close any unneeded software shown in the taskbar.

**Is the UA-101's sample rate set to a rate other than 192 kHz?**

If the UA-101's sample rate select switch is set to 192 kHz, the digital output connector and the digital input connector are not available.

**Are your input/output devices connected correctly?**

In order to play back audio/MIDI using the UA-101, you must make the appropriate input/output device settings. For details on making these settings, refer to "Driver settings" (p. 22).

If you are using the 192 kHz sample rate on Windows XP, the UA-101 may not appear in the Sounds tab of the Sounds and Audio Devices Properties dialog box. If so, please update your system to Windows XP Service Pack 1.

**Could the UA-101 have been connected when you started up the computer?**

Start up the computer with the UA-101 disconnected, and then connect the UA-101. Depending on the type of computer you are using, starting up the computer when the UA-101 is already connected may cause operation to be unstable. In this case, start up your computer and then connect the UA-101.

**Does the USB connector of your computer support USB 2.0 (Hi-Speed)?**

If your computer has correctly recognized the UA-101 in Hi-Speed USB mode, the USB indicator will light red. If this indicator is lit green, the UA-101 has been recognized in Full-Speed USB mode.

If the indicator is blinking, the UA-101 has not been recognized correctly.

<p><b>When blinking red Hi-Speed USB mode</b></p>	<p>It is possible that the USB connector of your computer does not support USB 2.0. Please refer to the owner's manual for your computer for details about its USB connectors.</p>
<p><b>When blinking green Full-Speed USB mode</b></p>	<p>In Full-Speed USB mode, only sample rates of 44.1 kHz and 48 kHz are supported. It may be that the sample rate select switch is set to a rate other than 44.1/48 kHz.</p>

**Refer to:** "USB indicator" (p. 12)  
"Hi-Speed USB mode switch" (p. 14)

### A device connected to the input jacks can't be heard through headphones

#### **Are the input sensitivity knobs and direct monitor volume knob set appropriately?**

Turn the knobs toward the right to adjust the volume.

#### **Is the monitor volume knob raised appropriately?**

Turn the knob toward the right to adjust the volume.

### Recording produces a silent file

#### **Did you specify the correct audio data input source within the operating system?**

Depending on the software you are using, you may need to specify the UA-101 as the audio data input source for your computer.

**Refer to:** “Driver settings” (p. 22)

### Can't record from a digital connection

#### **When capturing audio data from a CD or MD into your computer, is the digital input switch “on”?**

Turn on the digital input switch.

#### **Does the sample rate of your software match the sample rate of the digital audio device connected to the digital in connector?**

Set the sample rate to the same setting.

If you switch the UA-101's sample rate, you must turn the power of the UA-101 off, then on again to get the setting to take effect.

#### **Is the UA-101's digital input switch set correctly?**

The sync indicator will blink if the UA-101 is not correctly synchronized with the digital signal being received at the digital input connector. Make sure that the sample rate is set correctly. Also make sure that your digital device is correctly connected to the digital input connector, and that a digital signal is being input.

### Can't record/play 24-bit audio data

#### **Does your software support 24-bit audio data?**

You will need to use software that supports 24-bit audio data.

#### **Is your software set to record/play 24-bit audio data?**

Set your software to 24-bit.

## **Can't record/play MIDI**

### **Have you made the correct settings for the MIDI device you're using?**

In order to record/play MIDI via the UA-101, you must install the UA-101 driver correctly.

In addition, you must also make settings in your software to specify the MIDI device you want to use.

**Refer to:** “Installing the driver” (p. 16)  
“Driver settings” (p. 22)

# Noise or pops are heard when recording/ playing on your computer

Noise is heard during audio playback

Pops/clicks occur during audio playback

Noise is heard in the recorded sound

**In Windows, did you make the setting described in “Giving priority to background services”?**

In order to ensure that audio/MIDI processing occurs smoothly, make the setting described in “Giving priority to background services.”

Refer to: “Giving priority to Background Services” (p. 21)

**In Macintosh, check the Energy Saver settings.  
(Full-Speed Mode / USB1.1 12Mbps)**

In the Mac OS System Setup, set Energy Saver as follows.

Click the **Sleep** tab.

Set “Put the computer to sleep when it is inactive for:” to **Never**.

Set “Put the display to sleep when the computer is inactive for:” to **Never**.

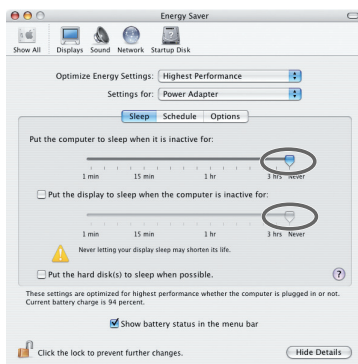

Click the **Options** tab.

If there is a **Processor Performance** setting, set it to **Highest**.

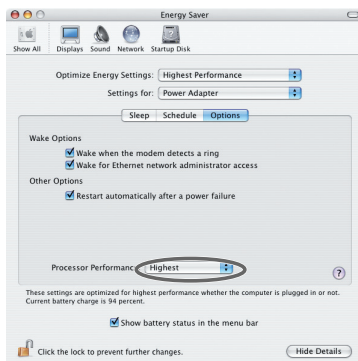

**In Windows, Power Management settings in the Control Panel may cause clicks or pops to occur in the audio playback.**

The power management properties that appear when you double-click Power Management will differ depending on your computer system. The explanation that follows is for a typical situation, but you should refer to the owner’s manual for your computer to verify these settings.

Some computers may not have the following items.

- 1.** In the Windows **Control Panel**, double-click the **System** icon. The **System Properties** dialog box will appear.
- 2.** Click the **Hardware** tab.
- 3.** Click **Device Manager** to see the list of devices.
- 4.** From the list, choose **Advanced Power Management Support**, and click **Properties**.  
The **Advanced Power Management Support Properties** dialog box will appear.
- 5.** Click the **Settings** tab, and in **Troubleshooting**, check the “**Don’t Poll Power Supply Status**” check box. Then click **[OK]**.
- 6.** In the **System Properties** dialog box, click **[OK]**.
- 7.** Restart Windows.

**Could two or more computers be connected to the UA-101 or to your mixer or audio devices?**

Try connecting the UA-101 to only one computer. Check whether the noise disappears when the UA-101 is connected to only one computer. Connecting numerous audio devices to a computer may produce noise in some situations. If this occurs, connect only the UA-101 to your computer.

**Are you using a USB device in addition to the UA-101?**

Try switching off USB audio devices other than the UA-101.  
If you have connected the UA-101 to an external USB hard disk, please connect the UA-101 directly to an USB connector on the computer itself.

**In Windows, you may be able to solve the problem by adjusting the buffer size in the UA-101 Driver Settings dialog box.**

Adjust the buffer size as described in “**Adjusting the audio latency**” (p. 41).

\* *After changing the buffer size, you must restart any software that uses the UA-101.*

If your software has an audio device test function, execute the test function.

### **Are numerous software programs running?**

Playback may be interrupted if numerous software programs are running at the same time, or when you start up another software program. Close any unneeded software, and try again. If this does not solve the problem, try restarting your computer.

### **Clicks or pops may occur in the sound if a LAN is operating.**

Try disabling the LAN in the Device Manager. If this eliminates the clicks or pops, you may be able to solve the problem by updating your LAN driver or BIOS.

### **Is the sample rate setting in your software the same as the UA-101's sample rate select switch setting?**

Set your software and the UA-101 to the same sample rate.

If you switch the UA-101's sample rate, you must turn the power of the UA-101 off, then on again to get the setting to take effect.

### **Try adding memory.**

Adding memory will improve the processing capability of your computer. For details on how to add memory, refer to the owner's manual of your computer.

### **Is the UA-101 connected to a USB hub?**

Try connecting the UA-101 directly to the USB connector of your computer itself.

### **Noise may be entering via the line inputs or mic inputs.**

If a MIDI sound module with a USB connector is connected via USB to the same computer as the UA-101, and the output of the MIDI sound module is connected to the input jacks of the UA-101, noise from the computer may be heard via the MIDI sound module from the UA-101. In this case, you can either connect the MIDI sound module and UA-101 in parallel via a self-powered hub, or connect the MIDI sound module in series or via a MIDI interface.

### **Are you using the included USB cable?**

You must use the included USB cable when using the UA-101. Some commercially available USB cables do not meet the requirements of the USB standard, and this may prevent the UA-101 from operating correctly.

---

**Playback/recording stops midway, and subsequent playback/recording is not possible**

**While you were using the UA-101, could your computer have performed a task with a heavy processing load, such as accessing a CD-ROM drive or network?**

If a heavy processing load occurs while the UA-101 is being used, it may not work correctly. In this case, stop playback/recording, and then start playback/recording once again. If you are still unable to play/record correctly, close all software that had been using the UA-101, and re-connect the UA-101.

**Digitally recorded sound has distortion, the wrong pitch, or contains noise**

**Is the sample rate setting in your software the same as the sample rate of the digital device connected to the digital input connector?**

Set your software and the UA-101 to the same sample rate.

If you switch the UA-101's sample rate, you must turn the power of the UA-101 off, then on again to get the setting to take effect.

**Playback sound from your computer is distorted**

**Are the input/output level indicators lit red?**

Use UA-101 Control Panel to lower the monitor level.

# Noise or distortion occurs when the UA-101 is not connected to your computer

## The sound is too weak

### Noise is heard in the sound

#### Has a mic or guitar been left connected?

If a mic or guitar is connected to the UA-101, disconnect the mic or guitar and turn the input sensitivity knob all the way toward the left (lowering the input level).

#### Have you connected the grounding terminal?

Connecting the chassis of your computer or the grounding terminal of your computer's AC power cord to an electrical ground may solve the problem. Also, make sure that a device that produces a strong magnetic field, such as a television or microwave oven, is not located nearby.

#### Could numerous audio devices be connected?

Noise may occur if numerous audio devices are connected. Do not connect audio devices you are not using.

### Sound of a device connected to the input jacks is distorted

### Insufficient volume from a device connected to the audio input/output jacks

#### Is the input level set appropriately?

If you're inputting audio through input jacks 3–8, use the input level select switches (p. 15) located on the rear panel of the UA-101 to adjust the input level.

#### Is the peak/limiter indicator lit red?

If you're inputting audio through the combo input jacks, use the UA-101's input sensitivity knobs to reduce the input level.

If you're inputting audio through the INPUT 2 combo input jack, check the setting of the input impedance select switch.

#### Is the direct monitor volume set appropriately?

Adjust the volume as described in Direct Monitor Volume (p. 12).



**A substantial amount of noise is present in the guitar sound****Does the noise decrease when you turn down the volume of your guitar?**

If the noise decreases when you turn down the volume of your guitar, the guitar pickup may be affected by noise from your computer or display. Try locating the guitar as far away from the computer as possible.

**Insufficient volume from your guitar****Are you using the correct jack?**

Connect your guitar to the INPUT 2 combo input jack.

**Is the input impedance select switch set correctly?**

Set the input impedance select switch to Hi-Z.

**Insufficient volume from a mic****Is the input level appropriate?**

Turn the input sensitivity knob toward the right to adjust the input volume.

# Others

## Can't start the Cubase

### **Are you using the UA-101 for the first time with Cubase?**

The first time you use the UA-101 with Cubase, turn on the power with the UA-101's sample rate select switch at the 44.1 kHz position.

If this switch is not set to 44.1 kHz, it may be impossible to start Cubase.

## Deleting the driver

- 1.** With the UA-101 disconnected, start up Windows.  
You must disconnect all USB cables except those for a USB keyboard and USB mouse (if used).
- 2.** From the Windows **start** menu, open the **Control Panel**.
- 3.** Click “**Switch to Classic view**” to choose the Classic view.  
If the Classic view is already selected, proceed to the next step.
- 4.** Double-click the **EDIROL UA-101** icon.
- 5.** From the Driver menu of **EDIROL UA-101 Control Panel**, choose Uninstall.
- 6.** Follow the instructions in the dialog box to uninstall the driver.

If you are unable to delete the driver as described above, you can use Uninstal.exe (found in the Driver folder of the CD-ROM) to delete the driver.  
For details, refer to Readme.htm in the Driver folder of the CD-ROM.

# Main specifications

## ● Number of Audio Record/Playback Channels

<44.1/48/88.2/96 kHz>

Record: 10 channels

Playback: 10 channels

(Full duplex)

<192 kHz>

Record: 6 channels

Playback: 6 channels

(Full duplex)

\* Depending on the computer you are using, you may be unable to obtain sufficient performance.

## ● Signal Processing

PC interface:24 bits

AD/DA Conversion:24 bits (linear)

## ● Sampling Frequency

Digital output:44.1/48/88.2/96 kHz

Digital input:44.1/48/88.2/96 kHz

AD/DA Conversion:44.1/48/88.2/96/192 kHz

## ● Frequency Response

96.0 kHz: 20 Hz to 40 kHz (+1/-1 dB)

88.2 kHz: 20 Hz to 40 kHz (+1/-1 dB)

48.0 kHz: 20 Hz to 22 kHz (+1/-1 dB)

44.1 kHz: 20 Hz to 20 kHz (+1/-1 dB)

## ● Nominal Input Level

Input Jack 1-2 (XLR type):-50 to -10 dBu

Input Jack 1-2 (1/4 inch TRS phone type):-35 to +4 dBu

Input Jack 3-8: -10 dBu to +4 dBu (balanced)

## ● Nominal Output Level

Output Jack 1-8: +4 dBu (balanced)

## ● Residual Noise Level (Typical)

(input terminated with 1 k ohms, MAIN VOLUME: 0 dB, INPUT SENS: +4 dBu,

DIRECT MONITOR VOLUME: OUT1/2 position, IHF-A typ., Balanced)

Output Jack 1-2: -97 dBu

## ● S/N RATIO (Typical)

OUTPUT: 107 dB (typ.)

INPUT: 101 dB (typ.)

**● Interface**

USB (Hi-Speed, Full-Speed)  
Digital input/output  
Optical type (conforms to IEC60958)  
MIDI IN/OUT

**● Connectors****<Front Panel>**

Input Jack 1–2 (XLR type / 1/4 inch TRS phone type)  
XLR type (balanced / phantom power +48 V)  
1/4 inch TRS phone type (balanced)

Digital Input Connector (Optical type)  
Digital Output Connector (Optical type)

Headphones Jack (Stereo 1/4 inch phone type)

**<Rear Panel>**

Input Jack 3–8 (1/4 inch TRS phone type (balanced))  
Output Jack 1–8 (1/4 inch TRS phone type (balanced))  
Monitor Output Jack (L, R) (1/4 inch TRS phone type (balanced))  
MIDI Connectors (In, Out)  
USB Connector

**● Power Supply**

DC 9 V (AC adaptor)

**● Current Draw**

1 A

**● Dimensions**

218.0 (W) x 159.1 (D) x 45.1 (H) mm  
8-5/8 (W) x 6-5/16 (D) x 1-13/16 (H) inches

**● Weight**

1.15 kg / 1 oz

**● Accessories**

Owner's Manual  
CD-ROM  
AC Adaptor  
USB cable

(0 dBu = 0.775 V rms)

*\* In the interest of product improvement, the specifications and/or appearance of this unit are subject to change without prior notice.*

# Index

## Numerics

5.1 ch ..... 32

## A

AC adaptor jack ..... 13

ASIO ..... 22–23

ASIO Buffer Size ..... 43

ASIO Direct Monitor ..... 44

Audio input device ..... 22

audio latency ..... 41

Audio output device ..... 22

## C

Combo input jacks ..... 9

Cubase ..... 25, 36

## D

DEVICE PANEL ..... 40

Digital input connector ..... 11

Digital input switch ..... 10, 30

Digital output connector ..... 11

Direct Monitor Mixer section ..... 11

Direct Monitor section ..... 11, 29

Direct Monitor Soft Control switch ..... 11, 29

Direct monitor volume ..... 12, 29–31

Driver Signing Options ..... 17

## E

EDIROL UA-101 ..... 22, 24

## F

Factory Reset ..... 45

Full-Speed USB mode ..... 14

## G

Grounding terminal ..... 13

## H

Headphone jack ..... 12

Hi-Speed USB mode ..... 14

Hi-Speed USB mode switch ..... 14

## I

Input impedance select switch ..... 9, 29

Input jacks ..... 15

Input level select switches ..... 15

INPUT MONITOR ..... 40

Input sensitivity knob ..... 9, 28

Input/output level indicators ..... 10

## L

Limiter switch ..... 10, 29

## M

MIDI ..... 22

MIDI IN ..... 22

MIDI IN/OUT connectors ..... 15

MIDI music playback ..... 24

MIDI OUT ..... 22

Monitor output jacks ..... 15

Monitor volume ..... 12

## O

optical ..... 11

Output jacks ..... 15

OUTPUT MONITOR ..... 40

## P

PATCH BAY ..... 40

Phantom power switch ..... 13, 29

Power indicator ..... 12

Power switch ..... 12

## S

Sample rate select switch ..... 11, 29–30

SEPARATED ports ..... 22, 42

SONAR ..... 25, 33

Sound playback ..... 24

Sound recording ..... 24

STEREO/MONO select switch ..... 11, 29

Sync indicator ..... 10

## U

UA-101 Control Panel ..... 38

USB cables ..... 8

USB connector ..... 15

USB indicator ..... 12

USB1.1 ..... 14

USB2.0 ..... 14

## W

WDM ..... 22–23



# Information

When you need repair service, call your nearest EDIROL/Roland Service Center or authorized EDIROL/Roland distributor in your country as shown below.

## EDIROL

### EUROPE

**EDIROL (Europe) Ltd.**  
Studio 3/4 114 Fower Road  
London W4 5PY U.K.  
TEL: +44 (0)20 8747 5949  
FAX: +44 (0)20 8747 5948  
http://www.edirol.com/europe

**Deutschland**  
TEL: 0700 33 47 65 20  
**France**  
TEL: 0810 000 371  
**Italia**  
TEL: 02 93778329

## Roland

### NORTH AMERICA

#### CANADA

**Roland Canada Music Ltd.**  
(Head Office)  
5480 Parkwood Way Richmond  
B. C., V6V 2M4 CANADA  
TEL: (604) 270 6626

**Roland Canada Music Ltd.**  
(Toronto Office)  
170 Admiral Boulevard  
Mississauga On L5T 2N6  
CANADA  
TEL: (905) 362 9707

**U. S. A.**  
**Roland Corporation U.S.**  
5100 S. Eastern Avenue  
Los Angeles, CA 90040-2938,  
U. S. A.  
TEL: (323) 890 3700

### AFRICA

#### EGYPT

**Al Fany Trading Office**  
91 Hagar Al Askalanj Street  
ARD El Golf, Heliopolis,  
Cairo 11341, EGYPT  
TEL: 202-417-1828

#### REUNION

**Maison FO - YAM Marcel**  
25 Rue Jules Hermann,  
Chaudron - BP79 971  
St. Clothilde Cedex,  
REUNION ISLAND  
TEL: (0262) 218-429

#### SOUTH AFRICA

**Paul Bothner(PTY)Ltd.**  
Royal Cape Park, Unit 24  
Londonderry Road, Ottery 7800  
Cape Town, SOUTH AFRICA  
TEL: (021) 799 4900

### ASIA

#### CHINA

**Roland Shanghai Electronics Co.Ltd.**  
5F, No.1500 Pingliang Road  
Shanghai 200990, CHINA  
TEL: (021) 5580-0800

**Roland Shanghai Electronics Co.Ltd.**  
(BEIJING OFFICE)  
10F, No.18-3 Section Anhuaili  
Chaoyang District Beijing  
100011 CHINA  
TEL: (010) 6426-5050

**Roland Shanghai Electronics Co.Ltd.**  
(GUANGZHOU OFFICE)  
2/F, No.30 Si You Nan Er Jie  
Yi Xiang, Wu Yang Xin Cheng,  
Guangzhou 510600, CHINA  
TEL: (020) 8736-0428

### HONG KONG

**Panasonic Music Ltd.**  
8th Floor, Railway Plaza, 39,  
Chatham Road South, T.S.T.,  
Kowloon, HONG KONG  
TEL: 2333 1863

### INDIA

**Rivera Digitec (India) Pvt. Ltd.**  
409, Nirman Kendra  
Mahalaksmi Flats Compound,  
Off. Dr. Edwin Moses Road,  
Mumbai-400011, INDIA  
TEL: (022) 2493 9051

### INDONESIA

**PT Citra IntRama**  
Jl. Cidong Timur No. 151-150  
Jakarta Pusat  
INDONESIA  
TEL: (021) 6324170

### KOREA

**Comos Corporation**  
1461-9, Seocho-Dong,  
Seocho Ku, Seoul, KOREA  
TEL: (02) 3486-8855

### MALAYSIA/ SINGAPORE

**Roland Asia Pacific Sdn. Bhd.**  
45-1, Block C2, Jalan PJU 1/39,  
Dataran Prima, 47301 Petaling  
Jaya, Selangor, MALAYSIA  
TEL: (03) 7805-3263

### PHILIPPINES

**G.A. Yupangco & Co. Inc.**  
1399 GIL Puyat Avenue  
Makati, Metro Manila 1200,  
PHILIPPINES  
TEL: (02) 899 9801

### TAIWAN

**ROLAND TAIWAN**  
**ENTERPRISE CO. LTD.**  
Room 5, 9F, No. 112 Chung  
Shan N.Road Sec. 2, Taipei,  
TAIWAN, R.O.C.  
TEL: (02) 2561 3339

### THAILAND

**Theraa Music Co., Ltd.**  
330 Soi Veeng Nakornkasem,  
New Road, Sumpantawongse,  
Bangkok 10100, THAILAND  
TEL: (02) 224-8821

### VIETNAM

**SAIGON MUSIC**  
**DISTRIBUTOR**  
**(TAN DINH MUSHC)**  
138 Tran Quang Khai Street  
Dist. 1, Ho Chi Minh City  
VIETNAM  
TEL: (08) 848-4068

### AUSTRALIA/ NEW ZEALAND

#### AUSTRALIA/ NEW ZEALAND

**Roland Corporation**  
**Australia Pty., Ltd.**  
38 Campbell Avenue  
Dove Way West, NSW 2099  
AUSTRALIA  
For Australia  
TEL: (02) 9982 8266  
For New Zealand  
TEL: (09) 3098 715

### CENTRAL/LATIN AMERICA

#### ARGENTINA

**Musicales Micales S.A.**  
Av. Santa Fe 2055  
(1123) Buenos Aires  
ARGENTINA  
TEL: (011) 4508-2700

### BARBADOS

**A&E Music Supplies LTD**  
12 Webster Industrial Park  
Wildey, St.Michael, Barbados  
TEL: (246)430-1100

### BRAZIL

**Roland Brasil Ltda.**  
Rua San Jose, 780 Sala B  
Parque Industrial San Jose  
Cotia - Sao Paulo - SP, BRAZIL  
TEL: (011) 4615 5666

### CHILE

**Comercial Fancy II S.A.**  
Rut: 96.919.420-1  
Nataaniel Cox #739, 4th Floor  
Santiago - Centro, CHILE  
TEL: (02) 688-9540

### COLOMBIA

**Centro Musical Ltda.**  
Cra 43 B No 25 A 41 Bododega 9  
Medellin, Colombia  
TEL: (57)43812529

### CURACAO

**Zeelandia Music Center Inc.**  
Orionweg 30  
Curacao, Netherland Antilles  
TEL: (059)592866

### DOMINICAN REPUBLIC

**Instrumentos Fernando Ginaldez**  
Calle Proyecto Central No.3  
Ens. La Esperilla  
Santo Domingo,  
Dominican Republic  
TEL: (0809) 683 0305

### ECUADOR

**Maw Musica**  
Rumichaca 822 y Zaruma  
Guayaquil - Ecuador  
TEL: (593)41203264

### GUATEMALA

**CA Instrumental**  
Calleada Roosevelt 34-01,zona 11  
Ciudad de Guatemala  
Guatemala  
TEL: (502) 599-2888

### HONDURAS

**Almancen Pajao AZUL S.A. de CV.**  
BO.Faz Barahona  
3 Ave.11 Calle 5-0  
San Pedro Sula, Honduras  
TEL: (504) 553-2029

### MARTINIQUE

**Musique & Son**  
Z.Les Mangle  
97232 La Lamanin  
Martinique F.W.I.  
TEL: 596 596 428660

### GIGAMUSIC SARKL

10 Rue De La Fudge  
97200 Fort De France  
Martinique F.W.I.  
TEL: 596 596 715222

### MEXICO

**Casa Veerkamp, s.a. de cv.**  
Av. Toluca No. 323, Cal. Olivar  
de los Padres 01780 Mexico  
D.F. MEXICO  
TEL: (55) 5668-6699

### NICARAGUA

**Bansabac Instrumentos**  
**Musicales Nicaragua**  
Almamina D'Este Calle Principal  
de la Farmacia Sta.Avenida  
1 Cuadra al Lago,#503  
Managua, Nicaragua  
TEL: (505)277-2557

### PERU

**Asudinet**  
**Distribuciones Musicales SAC**  
Juan Fanning 530  
Miraflores  
Lima - Peru  
TEL: (51) 4461388

### TRINIDAD

**AMR Ltd**  
Ground Floor  
Maritime Plaza  
Barataria Trinidad W.I.  
TEL: (868)628 6385

### URUGUAY

**Tudo Musica S.A.**  
Francisco Acuna de Figueroa 1771  
C.P.: 11.800  
Montevideo, URUGUAY  
TEL: (02) 924-2335

### VENEZUELA

**Instrumentos musicales**  
**Allegro.C.A.**  
Av.las industrias ed/Guitar  
import  
#7 zona Industrial de Turumo  
Caracas, Venezuela  
TEL: (212) 244-1122

### EUROPE

#### AUSTRIA

**Roland Elektronische**  
**Musikinstrumente HmbH.**  
Austrian Office  
Eduard-Bodem-Gasse 8,  
A-6020 Innsbruck, AUSTRIA  
TEL: (0512) 26 44 260

#### BELGIUM/FRANCE/ HOLLAND/ SWITZERLAND

**ROLAND CENTRAL EUROPE N.V.**  
Houtstraat 3, B-2260, Oevel  
(Westerlo) BELGIUM  
TEL: (014) 575811

#### CZECH REP.

**K.AUDIO**  
Kardasovska 626,  
CZ-198 00 Praha 9,  
CZECH REP.  
TEL: (2) 666 10529

#### DENMARK

**Roland Scandinavia A/S**  
Nordhavnsvej 7, Postbox 880,  
DK-2100 Copenhagen  
DENMARK  
TEL: 3916 6200

#### FINLAND

**Roland Scandinavia As, Filial**  
Finland  
Elamintie 5  
FIN-01510 Vantaa, FINLAND  
TEL: (09) 68 24 020

#### GERMANY

**Roland Elektronische**  
**Musikinstrumente HmbH.**  
Oststrasse 96, 22844  
Nordstedt, GERMANY  
TEL: (040) 52 60090

#### GREECE

**STOLLAS S.A.**  
**Music Sound Light**  
155, New National Road  
Patras 26442, GREECE  
TEL: 2610 435400

#### HUNGARY

**Roland East Europe Ltd.**  
Warehouse Area "DEFO" P183  
H-2046 Tokoralmint,  
HUNGARY  
TEL: (23) 511011

### IRELAND

**Roland Ireland**  
G2 Calmout Park, Calmout  
Avenue, Dublin 12  
Republic of IRELAND  
TEL: (01) 4294444

### ITALY

**Roland Italy S. P. A.**  
Viale delle Industrie 8,  
20020 Arese, Milano, ITALY  
TEL: (02) 957-78300

### NORWAY

**Roland Scandinavia Avd.**  
Kontor Norge  
Liljekarveien 2 Postboks 95  
Liljekarveien N-0216 Oslo  
NORWAY  
TEL: 22732 0074

### POLAND

**MX MUSIC SP.Z.O.O.**  
UL. Gibraltarska 4  
PL-03664 Warszawa POLAND  
TEL: (022) 679 44 19

### PORTUGAL

**Roland Iberia, S.L.**  
Portugal office  
Cais das Pedras, 8/9-1 Dto  
4050-045, Porto, PORTUGAL  
TEL: 22 608 00 60

### ROMANIA

**FBS LINES**  
Piata Libertatii 1,  
53550 Ghorgheni,  
ROMANIA  
TEL: (266) 364 609

### RUSSIA

**MuTeK**  
Dorozhnaya ul.3,korp.6  
117 545 Moscow, RUSSIA  
TEL: (095) 981-4967

### SPAIN

**Roland Iberia, S.L.**  
Paseo Garcia Faria, 33-35  
08005 Barcelona SPAIN  
TEL: 93 493 91 00

### SWEDEN

**Roland Scandinavia A/S**  
**SWEDISH SALES OFFICE**  
Danviks Center 28, 21 e  
S-131 30 Nacka SWEDEN  
TEL: (08) 702 00 20

### SWITZERLAND

**Roland (Switzerland) AG**  
Landstrasse 5, Postfach,  
CH-4452 Hingen,  
SWITZERLAND  
TEL: (061) 927-8383

### UKRAINE

**TIC-TAC**  
Mira Str. 19/108  
P.O. Box 180  
265400 Mukachevo,  
UKRAINE  
TEL: (03131) 414-40

### UNITED KINGDOM

**Roland (U.K.) Ltd.**  
Atlantic Close, Swansea  
Enterprise Park, SWANSEA  
SA7 9EJ,  
UNITED KINGDOM  
TEL: (01792) 702701

### MIDDLE EAST

#### BAHRAIN

**Moon Stores**  
No.16, Bab Al Bahrain Avenue,  
P.O.Box 247, Manama 304,  
State of BAHRAIN  
TEL: 17 211 005

### CYPRUS

**Roland Equipment Ltd.**  
17, Diagoras Street, Nicosia,  
CYPRUS  
TEL: (022) 66-9426

### IRAN

**MOCO INC.**  
No.41 Nike St., Dr.Shariyati Ave.,  
Roshan Cerah Miradasteh,  
Tehran, Iran  
TEL: (021) 285-4169

### ISRAEL

**Haditit F. Greenspoon & Sons**  
8 Retzi Ha'alyia Hashnya St.  
Liliseker N-0216 Oslo  
TEL: (03) 6823666

### JORDAN

**MUSIC HOUSE CO. LTD.**  
**FREDDY FOR MUSIC**  
P. O. Box 92846  
Amman 11192 JORDAN  
TEL: (06) 5692696

### KUWAIT

**EASA HUSAIN AL-YOUSIFI**  
**& SONS CO.**  
Abdullah Salem Street,  
1/2 Safa, KUWAIT  
TEL: 243-6399

### LEBANON

**Chahine S.A.L.**  
Gerge Zaidan St., Chahine  
Bldg., Achrafieh, P.O.Box 16-  
5857  
Beirut, LEBANON  
TEL: (01) 20-1441

### OMAN

**TALENTZ CENTRE L.L.C.**  
Malatan House No.1  
Al Noor Street, Rawi  
SULTANATE OF OMAN  
TEL: 2478 3443

### QATAR

**Badi Studio & Stores**  
P.O. Box 62,  
Doha, QATAR  
TEL: 423554

### SAUDI ARABIA

**adwailah Universal**  
**Electronics APJ**  
Corniche Road, Aldossary  
Bldg., 1st Floor, Al-Khobar,  
SAUDI ARABIA  
P.O.Box 2154, Al-Khobar 31952  
SAUDI ARABIA  
TEL: (03) 898 2081

### SYRIA

**Technical Light & Sound**  
**Center**  
Rawda, Abdul Qader Jazairi St.  
Bldg. No. 21, P.O.BOX 13520,  
Damascus, SYRIA  
TEL: (011) 223-8384

### TURKEY

**ZUHAL DUS TICARET A.S.**  
Galip Dede Cad. No.37  
Bevayga - Istanbul / TURKEY  
TEL: (012) 249 85 10

### U.A.E.

**Zak Electronics & Musical**  
**Instruments Co. L.L.C.**  
Zabeel Road, Al Sheroq Bldg.,  
No. 14, Grand Floor, Dubai,  
U.A.E.  
TEL: (04) 3360715

As of December 10, 2005 (EDIROL-I)



03899390

'06-2-2N