

V-Hi-Hat **VH-12**

Owner's Manual

The VH-12 V-Hi-Hat is to be used in combination with the Roland TD-20 or TD-12 Percussion Sound Module.

When using the VH-12, you will need to make the settings for the sound module. Refer to p. 8

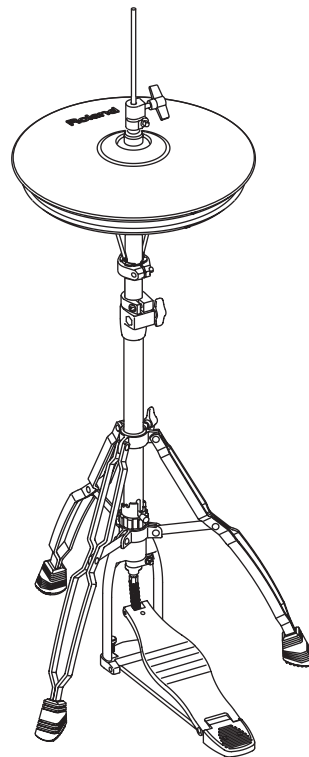



* **Hi-hat stand is not included.**



For details on compatible stands, refer to p. 10.

Before using this unit, carefully read the sections entitled: "USING THE UNIT SAFELY" and "IMPORTANT NOTES" (p. 2; p. 3). These sections provide important information concerning the proper operation of the unit. Additionally, in order to feel assured that you have gained a good grasp of every feature provided by your new unit, Owner's manual should be read in its entirety. The manual should be saved and kept on hand as a convenient reference.







USING THE UNIT SAFELY

INSTRUCTIONS FOR THE PREVENTION OF FIRE, ELECTRIC SHOCK, OR INJURY TO PERSONS

About  WARNING and  CAUTION Notices









 WARNING	Used for instructions intended to alert the user to the risk of death or severe injury should the unit be used improperly.
 CAUTION	Used for instructions intended to alert the user to the risk of injury or material damage should the unit be used improperly. * Material damage refers to damage or other adverse effects caused with respect to the home and all its furnishings, as well to domestic animals or pets.

About the Symbols



	The  symbol alerts the user to important instructions or warnings. The specific meaning of the symbol is determined by the design contained within the triangle. In the case of the symbol at left, it is used for general cautions, warnings, or alerts to danger.
	The  symbol alerts the user to items that must never be carried out (are forbidden). The specific thing that must not be done is indicated by the design contained within the circle. In the case of the symbol at left, it means that the unit must never be disassembled.
	The  symbol alerts the user to things that must be carried out. The specific thing that must be done is indicated by the design contained within the circle. In the case of the symbol at left, it means that the power-cord plug must be unplugged from the outlet.

ALWAYS OBSERVE THE FOLLOWING





WARNING

- Before using this unit, make sure to read the instructions below, and the Owner's Manual. 
- Do not open or perform any internal modifications on the unit. 
- Do not attempt to repair the unit, or replace parts within it (except when this manual provides specific instructions directing you to do so). Refer all servicing to your retailer, the nearest Roland Service Center, or an authorized Roland distributor, as listed on the "Information" page. 
- Never use or store the unit in places that are:
 - Subject to temperature extremes (e.g., direct sunlight in an enclosed vehicle, near a heating duct, on top of heat-generating equipment); or are 
 - Damp (e.g., baths, washrooms, on wet floors); or are 
 - Humid; or are
 - Exposed to rain; or are
 - Dusty; or are
 - Subject to high levels of vibration.
- Make sure you always have the unit placed so it is level and sure to remain stable. Never place it on stands that could wobble, or on inclined surfaces. 
- Do not allow any objects (e.g., flammable material, coins, pins); or liquids of any kind (water, soft drinks, etc.) to penetrate the unit. 

WARNING

- In households with small children, an adult should provide supervision until the child is capable of following all the rules essential for the safe operation of the unit. 
- Protect the unit from strong impact. (Do not drop it!) 

CAUTION

- Try to prevent cords and cables from becoming entangled. Also, all cords and cables should be placed so they are out of the reach of children. 
- Never climb on top of, nor place heavy objects on the unit. 
- Install the unit only on the hi-hat stand which satisfies the specifications described on p. 10. Remove the specified screws during the installation. 
- Should you remove clutch/clamp bolts, make sure to put them in a safe place out of children's reach, so there is no chance of them being swallowed accidentally. 
- Be careful not to allow your fingers or hands to be caught between the top and bottom hi-hat. 

IMPORTANT NOTES

In addition to the items listed under “USING THE UNIT SAFELY” on page 2, please read and observe the following:

Placement

- Do not expose the unit to direct sunlight, place it near devices that radiate heat, leave it inside an enclosed vehicle, or otherwise subject it to temperature extremes. Excessive heat can deform or discolor the unit.
- When moved from one location to another where the temperature and/or humidity is very different, water droplets (condensation) may form inside the unit. Damage or malfunction may result if you attempt to use the unit in this condition. Therefore, before using the unit, you must allow it to stand for several hours, until the condensation has completely evaporated.
- Do not allow rubber, vinyl, or similar materials to remain on the unit for long periods of time. Such objects can discolor or otherwise harmfully affect the finish.

Maintenance

- For everyday cleaning wipe the unit with a soft, dry cloth or one that has been slightly dampened with water. To remove stubborn dirt, use a cloth impregnated with a mild, non-abrasive detergent. Afterwards, be sure to wipe the unit thoroughly with a soft, dry cloth.
- Never use benzine, thinners, alcohol or solvents of any kind, to avoid the possibility of discoloration and/or deformation.

Additional Precautions

- Use a reasonable amount of care when using the unit’s buttons, sliders, or other controls; and when using its jacks and connectors. Rough handling can lead to malfunctions.
- When connecting / disconnecting all cables, grasp the connector itself—never pull on the cable. This way you will avoid causing shorts, or damage to the cable’s internal elements.
- To avoid disturbing your neighbors, try to keep the unit’s volume at reasonable levels. You may prefer to use headphones, so you do not need to be concerned about those around you (especially when it is late at night).

- This instrument is designed to minimize the extraneous sounds produced when it’s played. However, since sound vibrations can be transmitted through floors and walls to a greater degree than expected, take care not to allow these sounds to become a nuisance to neighbors, especially when performing at night and when using headphones.
- When you need to transport the unit, package it in the box (including padding) that it came in, if possible. Otherwise, you will need to use equivalent packaging materials.
- The hi-hat stand is supported by means of a tripod. When installing the hi-hat, make sure the legs of the tripod are opened wide enough to keep the equipment from falling over.
- The hi-hat’s rubber surface may turn white, but this has no effect on the hi-hat’s function.
- The section indicated by the arrows in the figure below contains high-precision sensors. Take care not to subject this to excessive shock, and do not allow any foreign objects to enter the gap.

Top Hi-Hat

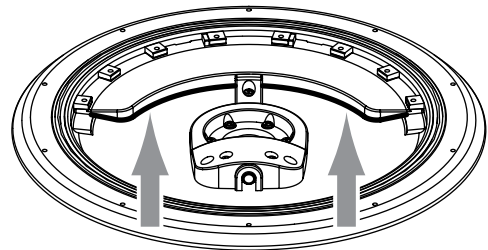

Bottom Hi-Hat

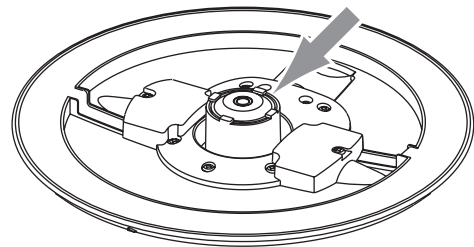

Getting Started

Features

Similar Touch and Feel as with an Acoustic Hi-Hat

The superior design has taken into account not only the shape of the hi-hat, but also the bounce of the stick, and even the movement caused by playing, making it possible to play with the same feel as an acoustic hi-hat.

Smooth Transition Between Closed and Open Tones

When you strike the pad while gradually opening the pedal, the tone smoothly opens in response to how much the pedal is opened.

Pressure Sensitive

You can alter the closed tone by continuing to press harder on the pedal after it is closed (p. 10).

Allows Foot Splashes

You can play foot splashes by pressing the pedal and then instantly opening it.

Quick-Open Tone Changes

Get realistic tonal changes by hitting the closed hi-hat and immediately opening it.

Natural-Feeling Action

The top hi-hat weight, gap between the top and bottom cymbals, and hi-hat stand tension gives the pedal action an extremely natural feel.

Dual Trigger Capability

Sensors in both the top and edge portion make it possible to get different sounds by striking the bow (upper surface) and the edge (p. 10).

They're Quiet!

Rubber is used on the striking surface for a damping effect.

Compatible with Commercially Available Hi-Hat Stands (p. 10)

Package Contents

Top Hi-Hat



Bottom Hi-Hat

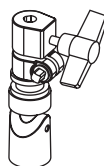
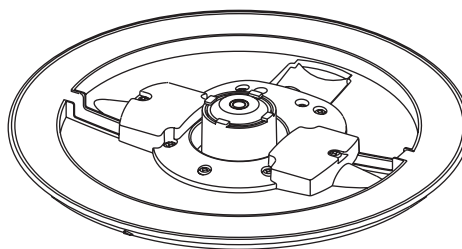

Special VH-12 Clutch

* The clutch included with the hi-hat stand will not be used.



Clamp

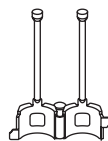

Holder (3 types)



Link Cable



Cable Tie



Tuning Key

Mounting on the Hi-Hat Stand

(1) Assembling the Top Hi-Hat

* Due to the different shape, the clutch included with the hi-hat stand cannot be used with the VH-12. Be sure to use the special VH-12 clutch.

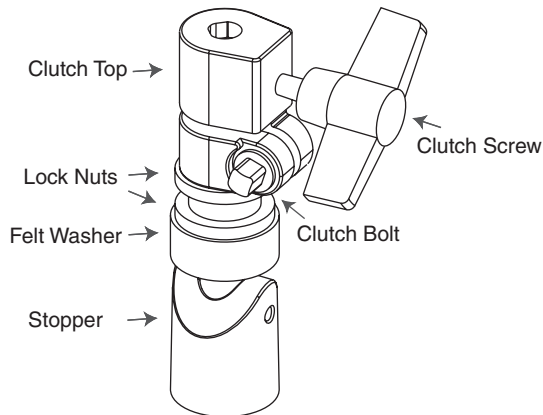

1. Use the tuning key included with the VH-12 to loosen the clutch bolt, then simultaneously turn and remove the clutch top.

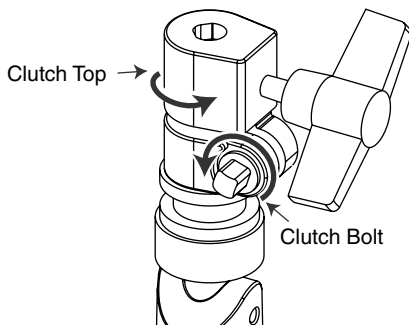

2. Remove the two lock nuts and the felt washer.
3. Pass the screw pipe of the stopper through from the underside of the top hi-hat.

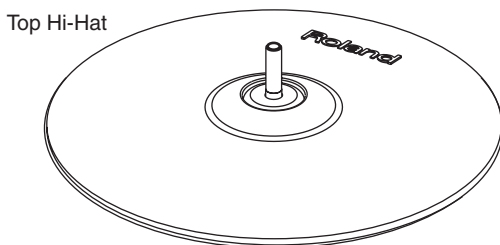

* Orient the stopper so that it matches the groove in the top hi-hat.

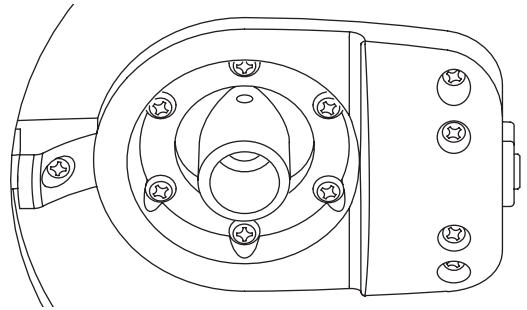

4. Attach the felt washer, the two lock nuts, and the clutch top, in that order, above the top hi-hat.
5. Confirm that the upper end of the screw pipe of the stopper can be seen through the slit of the clutch top, as shown in the figure.

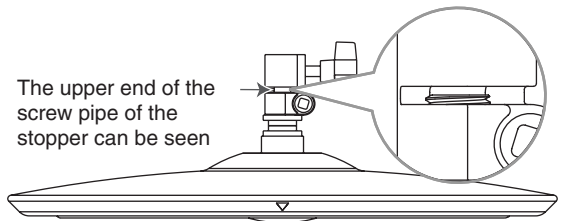

6. Orient the clutch screw so it's in a convenient location, then tighten the clutch bolt with the tuning key.
7. Securely tighten down the felt washer and two lock nuts.

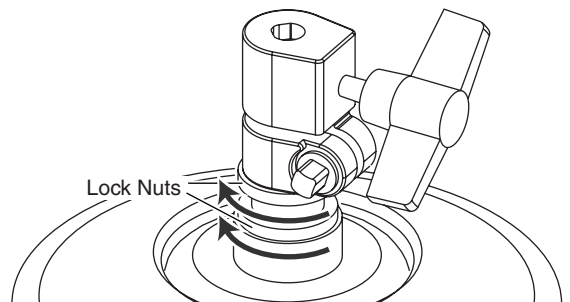

* Looseness or play in the clutch may prevent the hi-hat from operating properly.

(2) Assembling the Bottom Hi-Hat

1. Remove the clutch included with the hi-hat stand from the cymbal rod.

- * The clutch included with the hi-hat stand will not be used.
- * It is not necessary to remove the felt (or rubber) pad on the hi-hat stand used for supporting the bottom cymbal.

2. Confirm that the cymbal rod is firmly secured.

For instructions on tightening the cymbal rod, refer to the owner's manual for your cymbal stand.

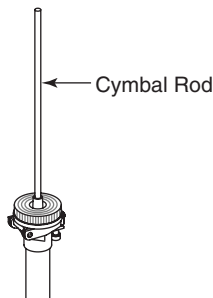

- * Looseness or play in the cymbal rod can make the top hi-hat unstable, causing it to shake or turn, and prevent proper functioning.

3. Place the bottom hi-hat on the hi-hat stand with the cymbal rod passing through the bottom hi-hat hole.

At this point, position the "▲" mark so it's facing the performer.

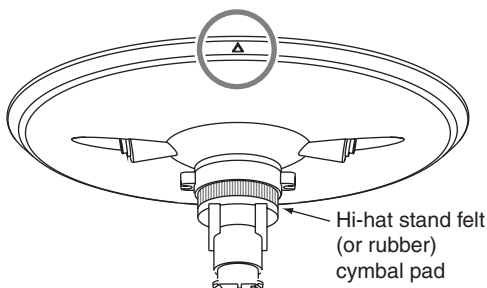

At this point, position the LINK jack so it's on the far side of the unit, facing away from the performer.

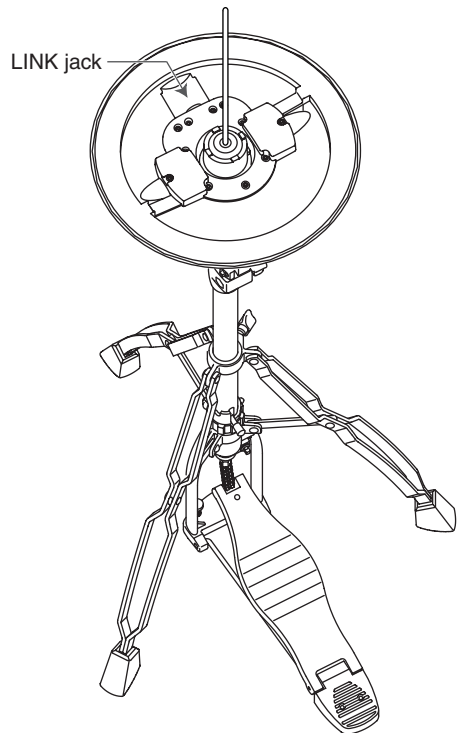

4. Select the holder that matches the diameter of the pipe at the top of the hi-hat stand.

There are three holders to match different pipe diameters.

L: 25.4 mm (1")

M: 22.2 mm (7/8")

S: 19.1 mm (3/4")

5. Remove the clamp bolt, then fit the holder and the clamp so they are nested together.

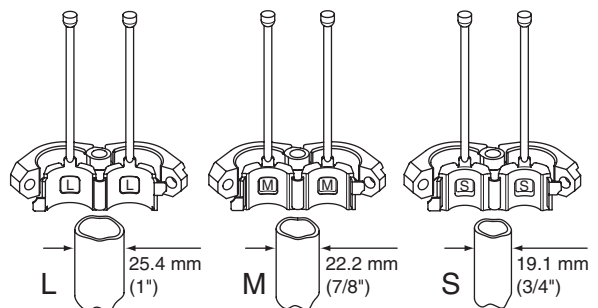

6. Attach the clamp and holder to the pipe on the upper part of the hi-hat stand, then slightly tighten the assembly with the tuning key.

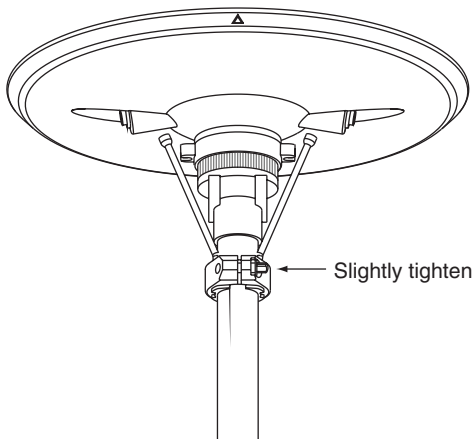

7. Pass the ends of the holder through the grooves in the metal portion of the bottom hi-hat, then while strongly pulling the clamp downward, secure it with the tuning key.

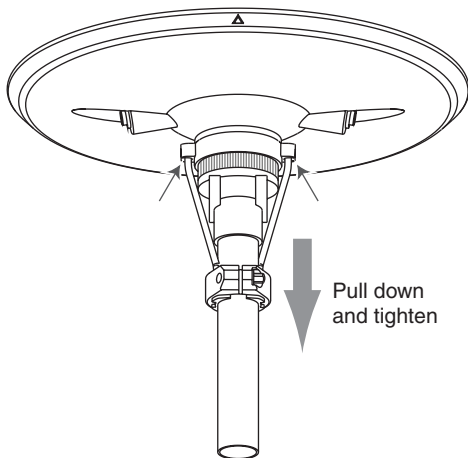

* Not pulling strongly enough on the clamp can make the bottom hi-hat unstable, causing it to shake or turn, and prevent proper functioning.

* After extended use of the hi-hat stand, the stand's felt (or rubber) pad on which the bottom cymbal rests becomes compressed, which may cause the bottom hi-hat to become unstable. If this occurs, loosen the clamp bolt and perform Step 7 again.

(3) Assembling the Overall Unit

1. Place the top hi-hat assembly on the hi-hat stand with the cymbal rod passing through the top hi-hat hole.

At this point, position the "Roland" logo on the farther side, as viewed from the performer.

2. Use the link cable to connect the bottom hi-hat and the top hi-hat LINK jacks.

3. Pull the bend of the cable softly with your fingers.

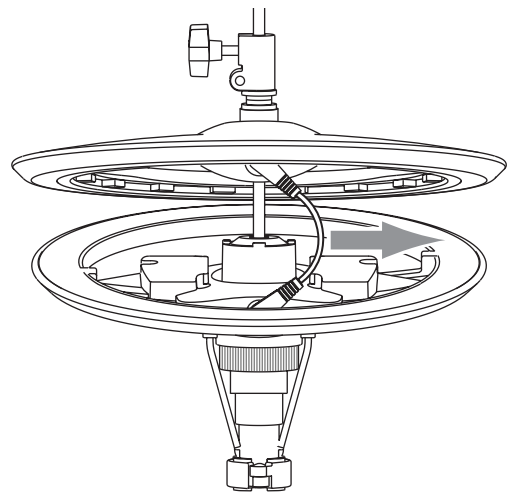

* Make sure that both the top hi-hat and bottom hi-hat can be closed smoothly.

(4) Connecting to a Sound Module

* To prevent malfunction and/or damage to speakers or other devices, always turn down the volume, and turn off the power on all devices before making any connections.

1. Connect the VH-12's TRIGGER OUTPUT jack to the sound module's TRIGGER INPUT HI-HAT jack, and the VH-12's CONTROL OUTPUT jack to the sound module's HH CTRL jack.

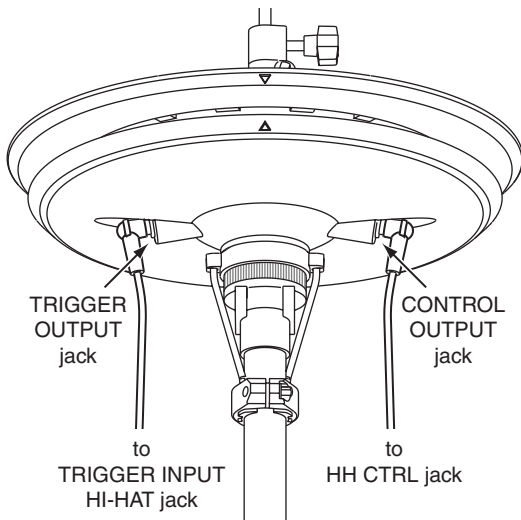

* Use stereo (TRS) cables to make the connections. If monaural cables are used, edge shots cannot be supported.

2. Secure the cables in place with the cable tie, while leaving some slack in the cables.

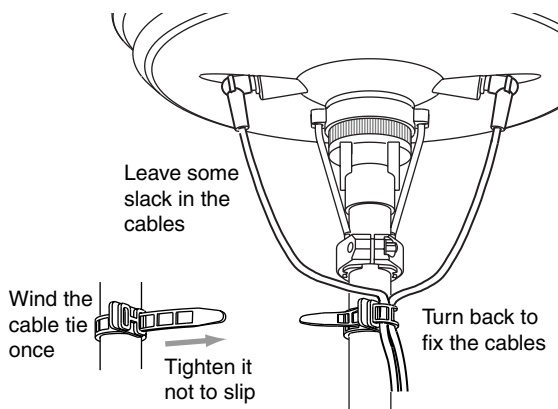

(5) Adjusting the Sound Module

When using the VH-12, you will need to make the settings for the sound module.

When Using with the TD-20

1. Loosen the clutch screw, and set the hi-hat in the closed position.
2. Hold down the TD-20's [KIT] button and press the [TRIGGER] button.

The offset is adjusted automatically.

When Using with the TD-12

1. Press the TD-12's [TRIGGER] button, then press the [F1 (BANK)] button.
2. Press the [CURSOR] buttons to move the cursor to the trigger type for TRIGGER INPUT 6.
3. Use the [+/-] buttons or the [VALUE] dial to select "VH12."
4. Press the [F3 (HI-HAT)] button.
5. Press the [CURSOR (up/down)] to move the cursor to "Hi-Hat Type."
6. Use the [+/-] buttons or the [VALUE] dial to set the Hi-Hat Type to "VH12."
7. Loosen the clutch screw, and set the hi-hat in the closed position.
8. Hold down the TD-12's [KIT] button and press the [TRIGGER] button.

The offset is adjusted automatically.



For details, refer to the TD-12 owner's manual.

(6) Adjusting the Hi-Hat

1. Adjust the gap between the top hi-hat and bottom hi-hat to a clearance of approximately 10 mm, then tighten the clutch screw.

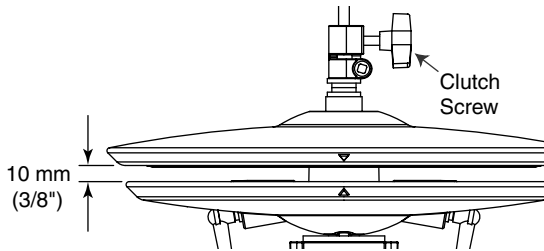

* Although the gap can be adjusted to a clearance that makes playing the hi-hat easier, setting too narrow or wide a gap can cause improper function of the unit and prevent the hi-hat from sounding as you intend. Setting the gap to **10 mm** provides the most natural feel when playing the VH-12.

2. Change the spring tension by adjusting the hi-hat stand.

For instructions on adjusting the tension, refer to the owner's manual for your hi-hat stand.

* The tension may not be adjustable on some stands.

NOTE

While playing, always align the marks on the top hi-hat and bottom hi-hat (▼ and ▲) to prevent malfunction.

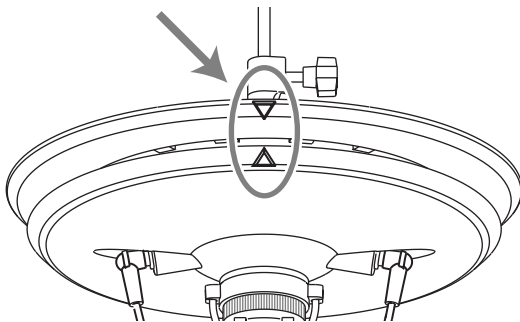

Playing Methods

Open/Closed

The hi-hat tone changes smoothly and continuously from open to closed in response to how far the pedal is pressed. You can also play the foot closed sound (playing the hi-hat with the pedal completely pressed down) and foot splash sound (playing the hi-hat with the pedal fully pressed and then instantly opening it).

Pressure

When you strike the hi-hat while pressing on the pedal with the hi-hat closed, you can then change the closed tone in response to the pressure you place on the pedal.

Bow Shot

This playing method involves striking the middle area of the top hi-hat. It corresponds to the sound of the "head-side" of the connected trigger input.

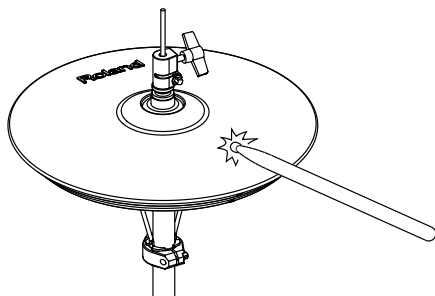

Edge Shot

This playing method involves striking the edge of the top hi-hat with the shoulder of the stick. When played as shown in the figure, the "rim-side" sound of the connected trigger input is triggered.

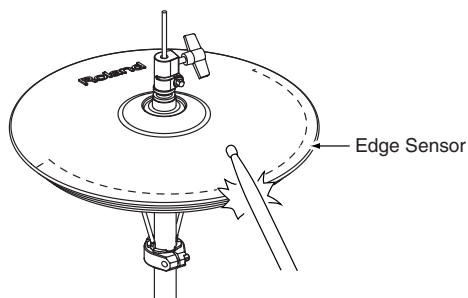

NOTE

Do not strike the bottom hi-hat or the underside of the top hi-hat.

Specifications

Size:	12 inches
Trigger:	2 (Bow /Edge)
Connectors:	TRIGGER OUTPUT Jack CONTROL OUTPUT Jack
Dimensions:	314 (W) x 314 (D) x 89 (H) mm 12-3/8 (W) x 12-3/8 (D) x 3-9/16 (H) inches
Weight:	1.9 kg / 4 lbs 4 oz
Options	Owner's Manual, Clutch, Clamp, Holder (3 types), Link Cable, Tuning Key, Cable Tie

* In the interest of product improvement, the specifications and/or appearance of this unit are subject to change without prior notice.

Compatible Stand

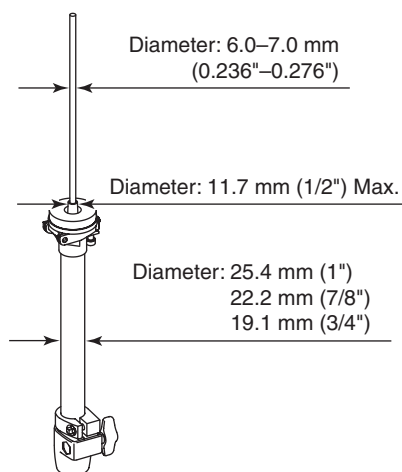

Troubleshooting

Hi-hat not closing

Was the unit adjusted after being connected to the sound module?

When using the VH-12, be sure to run the automatic offset adjustment on your sound module (p. 8).

No sound is heard

Is the TRIGGER OUTPUT connected to the sound module's HH CTRL jack?

Connect the VH-12's TRIGGER OUTPUT jack to the sound module's HI-HAT jack, and the CONTROL OUTPUT to the sound module's HH CTRL (p. 8).

The sound does not change when an edge shot is made

Is a monaural cable being used?

When a monaural cable is used, the sound does not change when an edge shot is made.

Use a stereo (TRS) cable.

Are you striking the area where an edge sensor is located?

The VH-12 has an edge sensor only at the area closest to you, at the front (p. 10).

Align the marks (▼ and ▲) on the top and bottom hi-hat, and position the marks so they face toward the player (p. 9).

Sounds are not triggering properly

Is the trigger type set correctly?

Make the trigger parameter settings for your sound module.

Are you using the special VH-12 clutch?

Clutches included with hi-hat stands are shaped differently than the VH-12's special clutch, so use of such other clutches prevent the sensors within the VH-12 from functioning properly. Be sure to use the clutch designed especially for the VH-12.

Is the clutch correctly attached to the top hi-hat?

Failure of the upper end of the screw pipe of the stopper to be seen through the slit of the clutch top is one cause of double triggering and incorrect opening and closing (p. 5, "Assembling the Top Hi-Hat" Step 5).

Loose lock nuts can cause improper functioning (p. 5, "Assembling the Top Hi-Hat" Step 7).

Is the bottom hi-hat attached correctly?

After extended use of the hi-hat stand, the stand's felt (or rubber) pad on which the bottom cymbal rests becomes compressed, which may cause the bottom hi-hat to become unstable. If this occurs, loosen the clamp bolt and perform Step 7 on p. 7 again.

Is the gap between the top and bottom hi-hat correct?

Setting too narrow or wide a gap can cause improper function of the unit and prevent the hi-hat from sounding as you intend. Setting the gap to 10 mm provides the most natural feel when playing the VH-12 (p. 9).

Is the sound module's offset adjusted correctly?

The offset may change somewhat as you perform. If this occurs, run the automatic offset adjustment procedure for the sound module once again (p. 8).

Information

When you need repair service, call your nearest Roland Service Center or authorized Roland distributor in your country as shown below.

AFRICA

EGYPT
Al Fanny Trading Office
9, EBN Hagar Al Askalany
Street,
ARD E1 Golf, Heliopolis,
Cairo 11341, EGYPT
TEL: 20-2-417-1828

REUNION
Maison FO - YAM Marcel
25 Rue Jules Hermann,
Chaudron - BP79 97 491
Ste Clotilde Cedex,
REUNION ISLAND
TEL: (0262) 218-429

SOUTH AFRICA
That Other Music Shop(PTY)Ltd.
11 Melle St., Braamfontein,
Johannesburg,
SOUTH AFRICA
TEL: (011) 403 4105
FAX: (011) 403 1234

Paul Bothner(PTY)Ltd.
Royal Cape Park, Unit 24
Londonderry Road, Ottery 7800
Cape Town, SOUTH AFRICA
TEL: (021) 799 4900

ASIA

CHINA
Roland Shanghai Electronics
Co.,Ltd.
5F, No.1500 Pingliang Road
Shanghai 200090, CHINA
TEL: (021) 5580-0800

Roland Shanghai Electronics
Co.,Ltd.
(BEIJING OFFICE)
10F, No.18 3 Section Anhuaxili
Chaoyang District Beijing
100011 CHINA
TEL: (010) 6426-5050

Roland Shanghai Electronics
Co.,Ltd.
(GUANGZHOU OFFICE)
2/F., No.30 Si You Nan Er Jie
Yi Xiang, Wu Yang Xin Cheng,
Guangzhou 510600, CHINA
TEL: (020) 8736-0428

HONG KONG
Tom Lee Music Co., Ltd.
Service Division
22-32 Pun Shan Street, Tseun
Wan, New Territories,
HONG KONG
TEL: 2415 0911

Parsons Music Ltd.
8th Floor, Railway Plaza, 39
Chatham Road South, T.S.T,
Kowloon, HONG KONG
TEL: 2333 1863

INDIA
Rivera Digitech (India) Pvt. Ltd.
409, Nirman Kendra
Mahalaxmi Flats Compound
Off. Dr. Edwin Moses Road,
Mumbai-400011, INDIA
TEL: (022) 2493 9051

INDONESIA
PT Citra IntiRama
Jl. Cideng Timur No. 15f-150
Jakarta Pusat
INDONESIA
TEL: (021) 6324170

KOREA
Cosmos Corporation
1461-9, Seocho-Dong,
Seocho Ku, Seoul, KOREA
TEL: (02) 3486-8855

MALAYSIA
Roland Asia Pacific Sdn. Bhd.
45-1, Block C2, Jalan PJU 1/39,
Dataran Prima, 47301 Petaling
Jaya, Selangor, MALAYSIA
TEL: (03) 7805-3263

PHILIPPINES
G.A. Yupangco & Co. Inc.
339 Gil J. Puyat Avenue
Makati, Metro Manila 1200,
PHILIPPINES
TEL: (02) 899 9801

SINGAPORE
SWEET LEE MUSIC
COMPANY PTE. LTD.
150 Sims Drive,
SINGAPORE 387381
TEL: 6846-3676

CRISTOFORI MUSIC PTE LTD
Blk 3014, Bedok Industrial Park E,
#02-2148, SINGAPORE 489980
TEL: 6243-9555

TAIWAN
ROLAND TAIWAN
ENTERPRISE CO., LTD.
Room 5, 9fl. No. 112 Chung
Shan N.Road Sec.2, Taipei,
TAIWAN, R.O.C.
TEL: (02) 2561 3339

THAILAND
Theera Music Co., Ltd.
330 Verg NakhonKasem, Soi 2,
Bangkok 10100, THAILAND
TEL: (02) 2248821

VIETNAM
SAIGON MUSIC
DISTRIBUTOR
(TAN DINH MUSIC)
138 Tran Quang Khai Street
Dist. 1, Ho Chi Minh City
VIETNAM
TEL: (08) 848-4068

AUSTRALIA/ NEW ZEALAND

**AUSTRALIA/
NEW ZEALAND**
Roland Corporation
Australia Pty.,Ltd.
38 Campbell Avenue
Dee Why West, NSW 2099
AUSTRALIA

For Australia
TEL: (02) 9982 8266
For New Zealand
TEL: (09) 3098 715

CENTRAL/LATIN AMERICA

ARGENTINA
Instrumentos Musicales S.A.
Av.Santa Fe 2055
(1123) Buenos Aires
ARGENTINA
TEL: (011) 4508-2700

BARBADOS
A&B Music Supplies LTD
12 Webster Industrial Park
Wildrey, St.Michael, Barbados
TEL: (246)430-1100

BRAZIL
Roland Brasil Ltda.
Rua San Jose, 780 Sala B
Parque Industrial San Jose
Cotia - Sao Paulo - SP, BRAZIL
TEL: (011) 4615 5666

CHILE
Comercial Fancy II S.A.
Rut.: 96.919.420-1
Natanjel Cox #739, 4th Floor
Santiago - Centro, CHILE
TEL: (02) 688-9540

COLOMBIA
Centro Musical Ltda.
Cra 43 B No 25 A 41 Bododega 9
Medellin, Colombia
TEL: (574)3812529

COSTA RICA
JUAN Bansbach Instrumentos
Musicales
Ave.1. Calle 11, Apartado 10237,
San Jose, COSTA RICA
TEL: 258-0211

CURACAO
Zeelandia Music Center Inc.
Orionweg 30
Curacao, Netherland Antilles
TEL:(305)5926866

DOMINICAN REPUBLIC
Instrumentos Fernando Giraldez
Calle Proyecto Central No.3
Ens.La Esperilla
Santo Domingo,
Dominican Republic
TEL:(809) 683 0305

ECUADOR
Mas Musika
Rumichaca 822 y Zaruma
Guayaquil - Ecuador
TEL:(593-4)2302364

EL SALVADOR
OMNI MUSIC
75 Avenida Norte y Final
Alameda Juan Pablo II,
Edificio No.4010 San Salvador,
EL SALVADOR
TEL: 262-0788

GUATEMALA
Casa Instrumental
Calzada Roosevelt 34-01,zona 11
Ciudad de Guatemala
Guatemala
TEL:(502) 599-2888

HONDURAS
Almacen Pajaro Azul S.A. de C.V.
BO.Paz Barahona
3 Ave.11 Calle S.O
San Pedro Sula, Honduras
TEL: (504) 553-2029

MARTINIQUE
Musique & Son
Z.I.Les Mangle
97232 Le Lamantin
Martinique F.W.I.
TEL: 596 596 426860

Gigamusic SARL
10 Rte De La Folie
97200 Fort De France
Martinique F.W.I.
TEL: 596 596 715222

MEXICO
Casa Veerkamp, s.a. de c.v.
Av. Toluca No. 323, Col. Oliver
de los Padres 01780 Mexico
D.F. MEXICO
TEL: (55) 5668-6699

NICARAGUA
Bansbach Instrumentos
Musicales Nicaragua
Alamira D'Este Calle Principal
de la Farmacia Sta.Avenida
1 Cuadra al Lago #503
Managua, Nicaragua
TEL: (505)277-2557

PANAMA
SUPRO MUNDIAL, S.A.
Boulevard Andrews, Albrook,
Panama City, REP. DE
PANAMA
TEL: 315-0101

PARAGUAY
Distribuidora De
Instrumentos Musicales
J.E. Olear y ESQ. Manduvira
Asuncion PARAGUAY
TEL: (595) 21 492147

PERU
Audionet
Distribuciones Musicales SAC
Juan Fanning 530
Miraflores
Lima - Peru
TEL: (511) 4461388

TRINIDAD
AMR Ltd
Ground Floor
Maritime Plaza
Barataria Trinidad W.I.
C.P.: (868) 638 6385

URUGUAY
Todo Musica S.A.
Francisco Acuna de Figueroa
1771
C.P.: 11.800
Montevideo, URUGUAY
TEL: (02) 924-2335

VENEZUELA
Instrumentos Musicales
Allegro,C.A.
Av.las industrias edf.Guitar
import
#7 Zona Industrial de Turumo
Caracas, Venezuela
TEL: (212) 244-1122

EUROPE

AUSTRIA
Roland Elektronische
Musikinstrumente HmbH.
Austrian Office
Eduard-Bodem-Gasse 8,
A-6020 Innsbruck, AUSTRIA
TEL: (0512) 26 44 260

**BELGIUM/FRANCE/
HOLLAND/
LUXEMBOURG**
Roland Central Europe N.V.
Houtstraat 3, B-2260, Oevel
(Westerlo) BELGIUM
TEL: (014) 575811

CZECH REP.
K-AUDIO
Kardasovska 626,
CZ-198 00 Praha 9,
CZECH REP.
TEL: (2) 666 10529

DENMARK
Roland Scandinavia A/S
Nordhavnsvej 7, Postbox 880,
DK-2100 Copenhagen
DENMARK
TEL: 3916 6200

FINLAND
Roland Scandinavia As, Filial
Finland
Elamontie 5
FIN-01510 Vantaa, FINLAND
TEL: (09) 68 24 020

GERMANY
Roland Elektronische
Musikinstrumente HmbH.
Oststrasse 96, 22844
Norderstedt, GERMANY
TEL: (040) 52 60090

GREECE
STOLLAS S.A.
Music Sound Light
155, New National Road
Patras 26442, GREECE
TEL: 2610 435400

HUNGARY
Roland East Europe Ltd.
Warehouse Area "DEPO" Pf.83
H-2046 Torokbalint,
HUNGARY
TEL: (23) 511011

IRELAND
Roland Ireland
G2 Calmout Park, Calmout
Avenue, Dublin 12
Republic of IRELAND
TEL: (01) 4294444

ITALY
Roland Italy S. p. a.
Viale delle Industrie 8,
20020 Arese, Milano, ITALY
TEL: (02) 937-78300

NORWAY
Roland Scandinavia Adv.
Kontor Norge
Lilleakerveien 2 Postboks 95
Lilleaker N-0216 Oslo
NORWAY
TEL: 2273 0074

POLAND
MX MUSIC SP.Z.O.O.
U.L. Gibraltarska 4,
PL-03664 Warszawa POLAND
TEL: (022) 679 44 19

PORTUGAL
Roland Iberia, S.L.
Portugal Office
Cais das Pedras, 8/9-1 Dto
4050-465, Porto, PORTUGAL
TEL: 22 608 00 60

ROMANIA
FBS LINES
Piata Libertatii 1,
535500 Gheorgheni,
ROMANIA
TEL: (266) 364 609

RUSSIA
MuTec
Dorozhnaya ul.3,korp.6
117 545 Moscow, RUSSIA
TEL: (095) 981-4967

SPAIN
Roland Iberia, S.L.
Paseo Garcia Faria, 33-35
08005 Barcelona SPAIN
TEL: 93.943 91 00

SWEDEN
Roland Scandinavia A/S
SWEDISH SALES OFFICE
Danvik Center 28, 2 tr.
S-131 30 Nacka SWEDEN
TEL: (08) 702 00 20

SWITZERLAND
Roland (Switzerland) AG
CH-4452 Ittingen,
SWITZERLAND
TEL: (061) 927-8383

UKRAINE
TIC-TAC
Mira Str. 19/108
P.O. Box 180
295400 Mukunkecho,
UKRAINE
TEL: (03131) 414-40

UNITED KINGDOM
Roland (U.K.) Ltd.
Atlantic Close, Swansea
Enterprise Park, SWANSEA
SA7 9FJ,
UNITED KINGDOM
TEL: (01792) 702701

MIDDLE EAST

BAHRAIN
Moon Stores
No.16, Bab Al Bahrain Avenue,
P.O.Box 247, Manama 304,
State of BAHRAIN
TEL: 17 211 005

CYPRUS
Radex Sound Equipment Ltd.
17, Diagorou Street, Nicosia,
CYPRUS
TEL: (022) 66-9426

IRAN
MOCO INC.
No.41 Nike St., Dr.Shariyat Ave.,
Roberoye Cerahe Mirdamad
Tehran, IRAN
TEL: (021) 285-4169

ISRAEL
Halilit P. Greenspoon & Sons Ltd.
8 Retzif Ha'aliya Hashnya St.
Tel-Aviv-Yafo ISRAEL
TEL: (03) 6823666

JORDAN
MUSIC HOUSE CO. LTD.
FREDDY FOR MUSIC
P. O. Box 922846
Amman 11192 JORDAN
TEL: (06) 5692696

KUWAIT
EASA HUSAIN AL-YOUSIFI
& SONS CO.
Abdullah Salem Street,
Safat, KUWAIT
TEL: 243-6399

LEBANON
Chahine S.A.L.
Gerge Zeidan St., Chahine
Bldg., Achrafieh, P.O.Box: 16-
5857
Beirut, LEBANON
TEL: (01) 20-1441

OMAN
TALENTZ CENTRE L.L.C.
Malatan House No.1
Al Noor Street, Ruwi
SULTANATE OF OMAN
TEL: 2478 3443

QATAR
Al Emadi Co. (Badie Studio &
Stores)
P.O. Box 62, Doha, QATAR
TEL: 4423-554

SAUDI ARABIA
aDawlah Universal
Electronics APL
Corniche Road, Aldossary
Bldg., 1st Floor, Alkhobar,
SAUDI ARABIA
P.O.Box 2154, Alkhobar 31952
SAUDI ARABIA
TEL: (03) 898 2081

SYRIA
Technical Light & Sound
Center
Rawda, Abdul Qader Jazairi St.
Bldg. No. 21, P.O.BOX 13520,
Damascus, SYRIA
TEL: (011) 223-5384

TURKEY
ZUHAI DIS TICARET A.S.
Galip Dede Cad. No.37
Beyoglu - Istanbul / TURKEY
TEL: (0212) 249 85 10

U.A.E.
Zak Electronics & Musical
Instruments Co. L.L.C.
Zabeel Road, Al Sherooq Bldg.,
No. 14, Grand Floor, Dubai,
U.A.E.
TEL: (04) 3360715

NORTH AMERICA

CANADA
Roland Canada Music Ltd.
(Head Office)
5480 Parkwood Way
Richmond B. C., V6V 2M4
CANADA
TEL: (604) 270 6626

Roland Canada Music Ltd.
(Toronto Office)
170 Admiral Boulevard
Mississauga On L5T 2N6
CANADA
TEL: (905) 362 9707

U. S. A.
Roland Corporation U.S.
5100 S. Eastern Avenue
Los Angeles, CA 90040-2938,
U. S. A.
TEL: (323) 890 3700

